

TABLE OF CONTENTS

Recharge Chemical, Fire Extinguishers, Clean Agent Systems

Recharge Chemical	2-3
Torrent Automatic Clean Agent Systems	4-5
Fireboy Automatic Clean Agent Systems	6-8
Strike First Fire Extinguishers	9-13
Amerex Fire Extinguishers	14-22
Ansul Fire Extinguishers	23-30

Covers Cabinets & Accessories

Hose Reel & Rack Covers	32, 35
Wheeled Unit Covers	32, 36
Fire Extinguisher Covers	33-35
Hydrant Covers	34, 36
Extinguisher Cabinets and Stands	37-43
Brooks Mark Series Cabinets	37
Cato Warrior Fire Extinguisher Cabinets	38
Heavy Duty Outdoor Series Extgr Cabinets	38
FireTech Fiberglass Cabinets	39
FireTech Fiberglass Stand	39
FireTech ABS Extgr Cabinet	39
CATO Chief Extgr Cabinet	40
Extinguisher Stands	40-41
Classic Series Metal Extgr Cabinets	41
Elite Architectural Extgr Cabinets	42-43
Access Doors	44-45
Cabinet Alarms, Fronts, Hammers, Locks and Labels	46-49
Fire Safety Plan Boxes	50
Extinguisher, Cabinet and Fire Hose Signs	50-51

Fire Hose Nozzles

Fire Hose Nozzles	54
Fire Hose Hydrotest Labels	54
Inspection Tags	55
Fire Hose	55-57
Rack and Reel Fire Hose	55
Single & Double Jacket Fire Hose	56
Washdown, Forestry, Rubber Covered Hose	57
Fire Hose Couplings, Expansion Rings & Gaskets	58
Hose Hangers, Racks, Reels & Trays	59
Hose Reel and Rack Covers	32, 60
Hose Valves	61
Angle Hose Valves	61
Gated Wye Valves	61
Adapters, Caps and Plugs	62-63

Municipal Hand Tools	63
Backpack Extinguishing System	63
Fire Hose Signs	64

Sprinkler Accessories & Standpipe Equipment

Sprinkler Gauges	66
Replacement Sprinkler Heads, Escutcheons & Accessories	66
Sprinkler Accessories	67
Valve Tamper Seals	67
Sprinkler Identification & Fire Department Signs	68, 69
Fire Sprinkler Monitoring	69-70
Alarm Pressure Switches	69
Supervisory Switches	70
Waterflow Detectors	70

Safety Products

Lockout Tagout	72-73
Locks	73-74
Transport of Dangerous Goods	74
Fire Protection and Equipment Log Books	74-75
Codes and Regulations	75
First Aid Signs	76
Waterjel Emergency Burn Care	76-77
Blankets, Ladders and Fire Retardant	77-78
Axes	79
Traffic and Roadside Safety	79
Form Holder	79
Eye Protection	79-80
Respiratory Protection	80-81
Plunger Dispensing Cans	81
Cigarette Butt Receptacles	81
Safety Storage Cabinets for Flammables	82-85
Disposal	85
Transfer Safety Cans	85-86
Protective Clothing	86

Fire Alarm Products

Conventional Fire Alarm Panels	88-90
2 to 6 Zone Panels	88
8 to 72 Zone Control Panels	88-89
Enclosures	89
Adder Modules	89
Alarm Remote Mount AUX. Relay	89
End of Line Resistor Plates	90

TABLE OF CONTENTS

MIR-65 Series Smoke Detector Kits	90
Intelligent Fire Alarm Control Panels	90-91
Intelligent Control Panels	90-91
Enclosures	91
Optional Modules	91
Remote Trouble Kit	91
Power Supplies	92
Releasing Panel	92-93
Releasing Panel	92
Optional Modules	93
Smart Relay	93
Abort Station	93
Annunciators	93-95
Graphic Annunciation Modules	93
Annunciators	94-95
Smart Relays	95
Annunciator Back Box	95
Conventional Detection/Input/Initiating Devices	96-98
Manual Alarm Pull Station	96-97
Abort Station	97
Smoke Detection	97
Heat Detection	98
Duct Detection	98
Intelligent Detection/Input/Initiating Devices	99-101
Intelligent Smoke and Heat Detectors	99
Intelligent Duct Detectors	100
Intelligent Input/Output Modules	100-101
Intelligent Pull Station	101
Signaling/Output Devices	102-103
Horns and Strobes	102-103
Mircom Supervised and Non Supervised Suite Isolators	103
Alarm Bells and Accessories	103
Replacement Mother Boards	104
Fire Alarm Electrical Cable	104
Fire Sprinkler Monitoring	105-106
Alarm Pressure Switches	105
Supervisory Switches	105
Waterflow Detectors	106
Fire Alarm Batteries	106-107
Alkaline Batteries	106
Lithium Batteries	106
Sealed Lead Acid Batteries	107
Smoke, CO Alarms & Accessories	108-115

Smoke Alarms	108-110
Carbon Monoxide Alarms	110-111
Smoke/CO Combination Alarms	112-114
Wireless Interconnect	114-115
Alarm Relay Modules & Alarm Adaptors	115
Pull Station Protectors	116-117
Universal Stopper Products	117
Horn/Strobe/Beacon Covers	118-119
Smoke Alarm Guard	119
Fire Alarm Inspection, Testing and Maintenance Products	120-126
Fire Alarm Service Labels	120
Detector Test Aerosols	120-121
Detector Removal and Cleaning	121
Alarm Component Testing	122
Solo Access Poles	122
Heat Detector Testing	122
Detector Test Kits	123
Multicriteria Detector Testing	124-125
Detector Sensitivity Testing	126

Exit and Emergency Lights

Exit and Emergency Lights	128-137
Self-luminous Tritium Exit Signs	128
Photoluminescent Exit Signs	128-129
Battery Units	129-132
Remote Heads	133
LED Combination Units	134-135
LED Exit Signs	136-137
Test Equipment and Labels	138
Wire Guards	139
Fire Alarm and Emergency Light Batteries	139-140
Alkaline Batteries	139
Lithium Batteries	140
Sealed Lead Acid Batteries	140
Replacement Bulbs	141

Signs, Labels and Tags

Custom Engraved Signs	144-145
Fire Extinguisher Signs	146-148
Extinguisher Cabinet Decals	148
Exit Signs and Directional Arrows	148-149
Fire Alarm Signs	149
Fire Hose Signs	150

TABLE OF CONTENTS

First Aid Signs	150-151
Danger Signs	151
Sprinkler Identification Signs	152-153
Fire Department and System Signs	153
Glow in the Dark Signs	154
No Smoking Signs	155
Extinguisher Operating Labels	155-156
WHMIS Labels	157
In Case of Fire Labels	157
Transport of Dangerous Goods Labels	157-158
Conductivity Cylinder and Hydrotest Labels	158-159
Service Tags	159-160
Inspection Tags	160-161
Tag Covers and Fasteners	161
Hole Punches and Chain Reel	162
Verification of Service Collars	162

Service Equipment

Hole Punches and Chain Reel	164
Tag Covers and Fasteners	164
Tamper Seals	165-166
Aerosols and Lubricants	166
Funnels, Scoops and Air Hose	167
Nitrogen Regulator and Accessories	168
Scales	168-169
Recharge Equipment	169
CO2 Recharge Equipment	170
Dry Chemical Recharge Adapters, Air Valves and Quick Disconnect Couplers	171
Hydrotest Adapters	172
Stamp Holder and Stamps	173
Conductivity and 6 Year Labels	174
Brushes	174
Fasteners	174-175
Gauge Service Equipment	175
Tools	175-177
Handcare Products	178
Headlights	178

Fire Extinguisher Parts

Gauges	180
Gauge Service Equipment	181
Valve Stems	181-184
O-Rings, Gaskets and Quad Rings	184-185

Rivets	185-186
Tamper Seals	186-187
Pull Pins, Chain & Key	187-188
Cartridge Bushings & Shipping Caps	188-189
CO2 Syphon Tubes	189
CO2 & Nitrogen Valves	189-191
CO2 Extinguisher Valves	189
Wheeled Unit Valves for Dry Chemical and CO2 Units	190
Brass Commercial CO2 Valves	190
Brass Commercial Nitrogen Valves	191
CO2 Safety Discs & Washers	191
CO2 Horns, Nipples & Handles	191-192
Replacement Bands and Straps	192-193
CO2 Hose Assemblies	193-194
Beverage Cylinder Equipment	194
Vehicle Brackets	195-196
Wall Hangers	197-198

Extinguisher Pictograms

Extinguisher Pictograms	200-255
Amerex	200-215
Ansul	216-225
Badger	226-233
Buckeye	234-237
Flag	238-243
Kidde	244-247
Pyrene	248-249
Sherwood CO2 & Nitrogen Commercial Valves	249
Pyro Chem	250
Strike First / Diamond	251-254
RS CO2 Valves	255

Restaurant System Parts

Gas Valves and Accessories	258-259
Manual Pull Station Guards	259
Microswitches	260
Reset Relays and Contactors	260-261
Stainless Steel Cable, Crimps and S-Hooks	261
Tools	262
Inspection and Installation Forms	263
Hood and Duct Mount Fasteners and Tools	263
Fusible Links	264-266
Link Brackets and Adapter Kit	267

TABLE OF CONTENTS

Temperature Labels	267
EMT Conduit Fittings	267
Grease-Tite Adapters and Patch Seals	268-269
Corner Pulleys	269
Pipe Fittings and Nipples	270
Stainless Steel Fittings and Pipe Nipples	270
Black Pipe Fittings and Pipe Nipples	271-272
Chromed Pipe Fittings and Pipe Nipples	272
Chrome Sleeving	272
Pipe Stand-Off Brackets	273
Hood and Duct Mount Fasteners and Tools	274
Hood Grease Filters and Accessories	274-275
Hood Filters	274
Filter Spacers	275
Hood Light Fixtures	275
Ductmate Rectangular Hi Temp Access Doors	276
Fryer Panels	276
Stainless Steel Cleaner/Polisher	276
Grease Comb	276
Firestop and Hood Caulk	277
Protective Clothing	277
Smoke Cartridges	277
Test Balloons	277
Codes and Regulations	278
System Signs	278
Ansul R-102 and Piranha Wet Chemical Systems	278-282
Kidde and Badger Range Guard Wet Chemical Systems	283-289
Badger Range Guard Dry Chemical System	283-289
Pyro-Chem Kitchen Knight System Parts	290-292

Getz, Shop Equipment

Dry Chemical Filling Systems	294-296
System Maintenance Parts and Kits	297-299
Shop and Mobile Packages	300-301
Dust Collection Systems	302
Hydrotest Equipment, Low Pressure	302-304
Hose Testers	305
Cylinder Vice	305
CO2 Transfer Pumps & Clean Agent Systems	306

- **RECHARGE CHEMICALS**
- **FIRE EXTINGUISHERS**
- **NAE[®] FIRE SYSTEMS**
- **FIREBOY[®] SYSTEMS**



RECHARGE CHEMICAL

ULC CLASSIFIED UNIVERSAL DRY CHEMICAL

STEEL FIRE ULC Classified dry chemical is manufactured at our Canadian facility. Our powder meets the requirements of **CAN/ULC S 514 M88 Powder Specifications**. Our dry chemical is ULC listed for the following manufacturers:

Amerex, Diamond, Ansul, Flag, Badger, General, Buckeye, Pyrene-Chubb, Strike First, Ansul PK Wheeled Units (Model LR-K-350-0, LR-K-350-D, LT-LR-K-350-C, LT-LR-K-350-D).

For information on specific model numbers refer to ULC listing information.



Steel Fire "ABC" Dry Chemical

STEEL FIRE ULC Classified "ABC" Dry Chemical is a specially formulated siliconized mono-ammonium phosphate/sulfate base dry chemical. The resultant agent is free flowing, water repellent, and anti-caking for smooth discharge. Our **SUPER90** formula featuring 90% siliconized Mono-Ammonium Phosphate is our High Performance ABC dry chemical.

ABC Dry Chemical is used to fight fires in ordinary combustible materials (Class A) such as wood, cloth, paper, rubber, and many plastics as well as fires in flammable liquids, gases and greases (Class B) and fires involving electrical equipment (Class C). It is electrically non-conductive.

STEEL FIRE ABC DRY CHEMICAL

PART#	DESCRIPTION	Ship Wgt (Lbs)
ABCX	ULC Classified ABC Dry Chemical, 50 lb. Carton (56% Siliconized Mono-Ammonium Phosphate) Model #750	51.5
ABCP	ULC Classified ABC Dry Chemical, 45 lb. Pail (56% Siliconized Mono-Ammonium Phosphate) Model #750	47.5
SUPER90	ULC Classified ABC Dry Chemical, 45 lb. Pail (90% Siliconized Mono-Ammonium Phosphate)	47.5



Steel Fire Regular "BC" and Purple-K "PK" Dry Chemical

STEEL FIRE ULC Classified Regular "BC" sodium bicarbonate based and **Purple-K "PK"** potassium bicarbonate based dry chemicals are specially formulated and manufactured for anti-caking, long discharge and smooth uninterrupted flow. The chemical is siliconized to be moisture repellent and provide minimum friction during discharge.

Regular "BC" and **Purple-K "PK"** chemical are used to fight fires in flammable liquids, gases, and greases (Class B) including such fires involving electrical equipment (Class C). Both agents are electrically non-conductive. Given its particular effectiveness on Class B fires, **Purple-K "PK"** has been the choice of oil, gas, chemical and utilities industries as the preferred fire-fighting agent.

STEEL FIRE REGULAR "BC" DRY CHEMICAL

PART#	DESCRIPTION	Ship Wgt (Lbs)
BCX	ULC Classified Regular "BC" Dry Chemical, 50 lb. Carton (Siliconized Sodium Bicarbonate) Model #754	51.5
BCP	ULC Classified Regular "BC" Dry Chemical, 50 lb. Pail (Siliconized Sodium Bicarbonate) Model #754	52.5



STEEL FIRE PURPLE-K "PK" DRY CHEMICAL

PART#	DESCRIPTION	Ship Wgt (Lbs)
PKP	ULC Classified Purple-K "PK" Dry Chemical, 50 lb. Pail (Siliconized Potassium Bicarbonate) Model #752	52.5

RECHARGE CHEMICAL

OEM DRY CHEMICAL

PART#	DESCRIPTION
AN53080	Ansul FORAY (ABC) Dry Chemical, Yellow Label, Pail
AN415788	Ansul Special FORAY (ABC) Dry Chemical, 45 lb. Pail <i>(for Models AA05, AA10S, AA20)</i>
AN9335	Ansul Purple-K Dry Chemical, 50lb. Pail
A545	Amerex Class D Powder, 50 lb. Pail <i>(Sodium Chloride)</i>



AN53080



A545

OEM WET CHEMICAL RECHARGE for a variety of Kitchen Systems and portable fire extinguisher types and models.

PART#	DESCRIPTION
AX530	Amerex 6L (1.59 Gal) K-Class Recharge
AX660	Amerex 2.5 Gal K-Class Recharge
A2117	AR-AFFF foam recharge for 254, 250X <i>(Replaces A502 and A504 Premix Charge)</i>
430182AS	Ansul 6L PRX Wet Chemical <i>For PIRANHA & K-Guard K01, K01-1</i>
423320AS	Ansul 5 Gal PRX Wet Chemical <i>For PIRANHA & K-Guard K01, K01-1</i>
79372AS	Ansulex 3 Gal Wet Chemical <i>For R-102 & K-Guard K01-2, K01-3</i>
B23168	Badger AC-100 6L (1.59 Gal) K-Class Recharge <i>For Badger WC-100, WC-250 and Kidde Pro Plus 100</i>
BU600872	Buckeye 6 L K-Class Recharge
120032KR	4 Gal APC Wet Chemical <i>For Badger Range Guard and Kidde WHDR Systems</i>
120033KR	6 Gal APC Wet Chemical <i>For Badger Range Guard and Kidde WHDR Systems</i>
PC300	Pyrochem 3 Gal Wet Chemical <i>For KITCHEN KNIGHT II & KITCHEN ONE K-Class Extgr</i>
PC553176	Pyrochem 6 L (1.6 Gal) Wet Chemical <i>For KITCHEN KNIGHT II & KITCHEN ONE K-Class Extgr</i>
SF6LK	Strike First 6 L K-Class Recharge
AC40	Anti-Freeze Charge for Pressure Water Extgrs <i>For 2.5 Gal PW Extinguishers (One AC40 per Extgr)</i>



AX530



423320AS



79372AS



B23168



PC300



120032KR



SF6LK



PC553176

We are in the business of growing your business

EXTINGUISHING SYSTEMS

Torrent Series Automatic Fire Extinguishers

Incontrol Systems' **TORRENT Series** of automatic clean agent fire extinguishers act fast to stop fires before they can spread and damage your assets. With discharge times of 10 seconds or less, installations benefit from fast response to the danger posed by fire.

Totally self-contained and fully automatic, the TORRENT fire extinguishers require no external power or connections, yet they maintain fire protection around the clock, delivering years of reliable service. Installation takes just minutes, and relocation is easily accomplished to suit changing fire protection needs.

- ULC Listed, Accepted by Canadian Coast Guard, US Coast Guard Approved (Manual pull station not listed)
- FM-200 / HFC227ea clean agent for effective fire protection
- On board pressure gauge for easy status checks
- Integrated heat detector (sprinkler bulb) reacts instantly to fire conditions
- Approved for use in occupied areas
- Suitable for Class A, B, & C hazards
- Simple installation and maintenance
- No residue – safe for sensitive equipment
- Self-contained – no external power necessary
- Mounting hardware included
- Accessory connections for pressure switch, discharge indicator, or manual operation
- Different temperature options for heat detection available, 135°F (57°C), 155°F (68°C), 175°F (79°C), 200°F (93°C)
- **Operating Temperature Range 32°F to +130°F (0°C to +54.4°C)**

MODEL NO.	MODEL DESCRIPTION	AGENT FILLING (LB.)	MAX PROTECTED SPACE		HEIGHT (IN.)	SHELL DIA. (IN.)	SHIP WGT (LBS)
			CLASS A FIRE (CU FT)	CLASS B (MARINE) (CU FT)			
SFS-06-XXX-P	6 lb. Auto Extgr c/w pressure switch	6	139	139	14	4.25	13
SFS-06-XXX-S	6 lb. Automatic Extgr	6	139	139	14	4.25	13
SFM-07-XXX-P	7 lb. Auto Extgr c/w pressure switch	7	205.3	162.16	19	5.125	18
SFM-07-XXX-S	7 lb. Automatic Extgr	7	205.3	162.16	19	5.125	18
SFM-09-XXX-P	9 lb. Auto Extgr w/ pressure switch	9	263.95	208.49	19	5.125	20
SFM-09-XXX-S	9 lb. Automatic Extgr	9	263.95	208.49	19	5.125	20
SFM-12-XXX-P	12 lb. Auto Extgr w/ pressure switch	12	277.99	277.99	19	5.125	23
SFM-12-XXX-S	12 lb. Automatic Extgr	12	277.99	277.99	19	5.125	23
SFL-15-XXX-P	15 lb. Auto Extgr w/ pressure switch	15	439.92	347.49	21.5	7.125	34
SFL-15-XXX-S	15 lb. Auto Extgr Automatic Extgr	15	439.92	347.49	21.5	7.125	34
SFL-20-XXX-P	20 lb. Auto Extgr w/ pressure switch	20	555.99	463.32	21.5	7.125	39
SFL-20-XXX-S	20 lb. Automatic Extgr	20	555.99	463.32	21.5	7.125	39
SFL-24-XXX-P	24 lb. Auto Extgr w/ pressure switch	24	555.99	555.99	21.5	7.125	43
SFL-24-XXX-S	24 lb. Automatic Extgr	24	555.99	555.99	21.5	7.125	43



MODEL NO.	MODEL DESCRIPTION	AGENT FILLING (LB.)	MAX PROTECTED SPACE				SHIP WGT (LBS)
			CLASS A FIRE (CU FT)	CLASS B (MARINE) (CU FT)	HEIGHT (IN.)	SHELL DIA. (IN.)	
SFX-31-XXX-P	31 lb. Auto Extgr w/ pressure switch	31	909.17	718.15	17.625	12.375	74
SFX-31-XXX-S	31 lb. Automatic Extgr	31	909.17	718.15	17.625	12.375	74
SFX-36-XXX-P	36 lb. Auto Extgr w/ pressure switch	36	972.97	833.98	17.625	12.375	79
SFX-36-XXX-S	36 lb. Automatic Extgr	36	972.97	833.98	17.625	12.375	79
SFX-42-XXX-P	42 lb. Auto Extgr w/ pressure switch	42	972.97	972.97	17.625	12.375	85
SFX-42-XXX-S	42 lb. Automatic Extgr	42	972.97	972.97	17.625	12.375	85



Ordering Info: Specify the temperature option when ordering. For example, if you want a model SFS-06, NO pressure switch, 175°F (79°C) bulb. The part number is SFS-06-175-S.

ACCESSORIES

The remote manual control kit enables the automatic extinguisher to be manually controlled from a safe, remote location. Two assemblies make up the remote manual control: Actuator Assembly, Pull Station and Cable Assembly. **(NOTE: The manual actuator is NOT UL/ULC/USCG listed.)**

PART#	DESCRIPTION
SPG	Economy Sprinkler Guard
SF-DI	SF Series Discharge Indicator
9-0010	Engine Shut Down Unit, 6 Contacts, 12-24 VDC
SF-MCS-10	Manual Control and Cylinder Actuator for S/M/L cylinders c/w 10 feet of cable
SF-MCS-15	Manual Control and Cylinder Actuator for S/M/L cylinders c/w 15 feet of cable
SF-MCS-20	Manual Control and Cylinder Actuator for S/M/L cylinders c/w 20 feet of cable
SF-MCX-10	Manual Control and Cylinder Actuator for X cylinders c/w 10 feet of cable
SF-MCX-15	Manual Control and Cylinder Actuator for X cylinders c/w 15 feet of cable
SF-MCX-20	Manual Control and Cylinder Actuator for X cylinders c/w 20 feet of cable
120043	Door Warning Sign, English
120058	Door Warning Sign, French



TORRENT SERIES MANUAL CONTROL

Fireboy MA2 HFC-227 ea

Manual / Automatic Discharge Fire Extinguisher MA2 Series

Max Coverage Up to 1,500 cubic feet

MODEL NO.	MAX VOL. PROTECTED (CU. FT)	SHELL DIA. (IN.)	HEIGHT (IN.)	SHIP WGT (LBS)
MA2025227-BL	25 cu. ft.	3.3"	9.5"	5 lbs.
MA2050227-BL	50 cu. ft.	3.3"	13.3"	8 lbs.
MA2075227-BL	75 cu. ft.	4.3"	15.6"	13 lbs.
MA2100227-BL	100 cu. ft.	4.3"	15.6"	14 lbs.
MA2125227-BL	125 cu. ft.	4.3"	15.6"	15 lbs.
MA2150227-BL	150 cu. ft.	5.1"	17.2"	20 lbs.
MA2175227-BL	175 cu. ft.	5.1"	17.2"	21 lbs.
MA2200227-BL	200 cu. ft.	5.1"	17.2"	22 lbs.
MA2225227-BL	225 cu. ft.	6.3"	17.3"	29 lbs.
MA2250227-BL	250 cu. ft.	6.3"	17.3"	30 lbs.
MA2275227-BL	275 cu. ft.	6.3"	17.3"	31 lbs.
MA2300227-BL	300 cu. ft.	6.3"	17.3"	32 lbs.
MA2325227-BL	325 cu. ft.	7.1"	17.2"	37 lbs.
MA2350227-BL	350 cu. ft.	7.1"	17.2"	38 lbs.
MA2375227-BL	375 cu. ft.	7.1"	17.2"	39 lbs.
MA2400227-BL	400 cu. ft.	7.1"	19.4"	43 lbs.
MA2450227-BL	450 cu. ft.	7.1"	19.4"	45 lbs.
MA2500227-BL	500 cu. ft.	7.1"	27.4"	55 lbs.
MA2550227-BL	550 cu. ft.	7.1"	27.4"	57 lbs.
MA2600227-BL	600 cu. ft.	7.1"	27.4"	60 lbs.
MA2650227-BL	650 cu. ft.	7.1"	27.4"	62 lbs.
MA2700227-BL	700 cu. ft.	7.1"	27.4"	64 lbs.
MA2750227-BL	750 cu. ft.	7.1"	33.3"	70 lbs.
MA2800227-BL	800 cu. ft.	7.1"	33.3"	73 lbs.
MA2850227-BL	850 cu. ft.	7.1"	33.3"	76 lbs.
MA2900227-BL	900 cu. ft.	7.1"	33.3"	77 lbs.
MA2950227-BL	950 cu. ft.	7.1"	33.3"	80 lbs.
MA21000227-BL	1000 cu. ft.	10"	21.4"	93 lbs.
MA21050227-BL	1050 cu. ft.	10"	21.4"	96 lbs.
MA21100227-BL	1100 cu. ft.	10"	21.4"	99 lbs.
MA21150227-BL	1150 cu. ft.	10"	27.5"	108 lbs.
MA21200227-BL	1200 cu. ft.	10"	27.5"	111 lbs.
MA21250227-BL	1250 cu. ft.	10"	27.5"	113 lbs.
MA21300227-BL	1300 cu. ft.	10"	27.5"	116 lbs.
MA21350227-BL	1350 cu. ft.	10"	27.5"	119 lbs.
MA21400227-BL	1400 cu. ft.	10"	27.5"	121 lbs.
MA21450227-BL	1450 cu. ft.	10"	27.5"	124 lbs.
MA21500227-BL	1500 cu. ft.	10"	27.5"	126 lbs.

FEATURES

- Protects engine rooms and machinery spaces up to 1500 cubic feet
- Pre-engineered, total flooding system
- The safest way to combat an engine room fire
- Automatic discharge at 175°F (79°C) with optional manual release
- With HFC-227ea – effective Halon replacement clean agent
- No water or powdery residue
- Includes powder coated mounting bracket and 2" L.E.D. panel light (#FBLKIT)
- 3-Year Limited Warranty
- Approved for class B fires

MA2 SERIES LISTINGS & APPROVALS

- Factory Mutual
- ISO RINA
- PED BV Final
- USCG
- MCA Certified
- Bureau Veritas



Fireboy MA2 Series

NEW Fireboy MA Series 3M™ Novec™ 1230

Manual / Automatic Discharge Fire Extinguisher MA2 Series
Max Coverage Up to 1,800 cubic feet

MODEL NO.	MAX VOL. PROTECTED (CU. FT)	SHELL DIA. (IN.)	HEIGHT (IN.)	SHIP WGT (LBS)
▶ MA0025NVC	25 cu. ft.	3.3"	12.4"	5 lbs.
▶ MA0050NVC	50 cu. ft.	3.3"	16.2"	9 lbs.
▶ MA0075NVC	75 cu. ft.	4.3"	18.5"	14 lbs.
▶ MA0100NVC	100 cu. ft.	4.3"	18.5"	15 lbs.
▶ MA0125NVC	125 cu. ft.	5.1"	20.2"	19 lbs.
▶ MA0150NVC	150 cu. ft.	5.1"	20.2"	24 lbs.
▶ MA0175NVC	175 cu. ft.	6.3"	20.2"	26 lbs.
▶ MA0200NVC	200 cu. ft.	6.3"	20.2"	28 lbs.
▶ MA0225NVC	225 cu. ft.	6.3"	20.2"	32 lbs.
▶ MA0250NVC	250 cu. ft.	6.3"	20.2"	33 lbs.
▶ MA0275NVC	275 cu. ft.	7.1"	19.9"	37 lbs.
▶ MA0300NVC	300 cu. ft.	7.1"	19.9"	38 lbs.
▶ MA0325NVC	325 cu. ft.	7.1"	22.3"	43 lbs.
▶ MA0350NVC	350 cu. ft.	7.1"	22.3"	44 lbs.
▶ MA0375NVC	375 cu. ft.	7.1"	22.3"	46 lbs.
▶ MA0400NVC	400 cu. ft.	7.1"	30.3"	53 lbs.
▶ MA0450NVC	450 cu. ft.	7.1"	30.3"	56 lbs.
▶ MA0500NVC	500 cu. ft.	7.1"	30.3"	61 lbs.
▶ MA0550NVC	550 cu. ft.	7.1"	30.3"	63 lbs.
▶ MA0600NVC	600 cu. ft.	7.1"	36.5"	72 lbs.
▶ MA0650NVC	650 cu. ft.	7.1"	36.5"	76 lbs.
▶ MA0700NVC	700 cu. ft.	7.1"	36.5"	78 lbs.
▶ MA0750NVC	750 cu. ft.	7.1"	36.5"	84 lbs.
▶ MA0800NVC	800 cu. ft.	10"	24.5"	90 lbs.
▶ MA0850NVC	850 cu. ft.	10"	24.5"	93 lbs.
▶ MA0900NVC	900 cu. ft.	10"	30.7"	103 lbs.
▶ MA0950NVC	950 cu. ft.	10"	30.7"	107 lbs.
▶ MA1000NVC	1,000 cu. ft.	10"	30.7"	109 lbs.
▶ MA1050NVC	1,050 cu. ft.	10"	30.7"	113 lbs.
▶ MA1100NVC	1,100 cu. ft.	10"	30.7"	116 lbs.
▶ MA1150NVC	1,150 cu. ft.	10"	30.7"	125 lbs.
▶ MA1200NVC	1,200 cu. ft.	10"	30.7"	129 lbs.
▶ MA1250NVC	1,250 cu. ft.	10"	35.5"	130 lbs.
▶ MA1300NVC	1,300 cu. ft.	10"	35.5"	134 lbs.
▶ MA1350NVC	1,350 cu. ft.	10"	35.5"	137 lbs.
▶ MA1400NVC	1,400 cu. ft.	10"	35.5"	140 lbs.
▶ MA1450NVC	1,450 cu. ft.	10"	35.5"	143 lbs.
▶ MA1500NVC	1,500 cu. ft.	10"	35.5"	146 lbs.

FEATURES

- Protects engine rooms and machinery spaces up to 1,800 cubic feet with 3M™ Novec™ 1230
- Pre-engineered, total flooding system
- The safest way to combat an engine room fire
- Automatic discharge at 175°F (79°C) with optional manual release
- 3M™ Novec™ 1230
- No water or powdery residue
- Includes locking lever for increased safety when removing or installing cable
- Includes powder coated mounting bracket and 2 in. L.E.D. helm display
- 3-Year Limited Warranty
- Approved for Class B fires

MA2 SERIES LISTINGS & APPROVALS

- Factory Mutual
- ISO RINA
- PED BV Final
- USCG
- MCA Certified
- Bureau Veritas

Chart Continued

MODEL NO.	MAX VOL. PROTECTED (CU. FT)	SHELL DIA. (IN.)	HEIGHT (IN.)	SHIP WGT (LBS)
▶ MA1550NVC	1,550 cu. ft.	10"	44.7"	153 lbs.
▶ MA1600NVC	1,600 cu. ft.	10"	44.7"	156 lbs.
▶ MA1650NVC	1,650 cu. ft.	10"	44.7"	159 lbs.
▶ MA1700NVC	1,700 cu. ft.	10"	44.7"	162 lbs.
▶ MA1750NVC	1,750 cu. ft.	10"	44.7"	166 lbs.
▶ MA1800NVC	1,800 cu. ft.	10"	44.7"	169 lbs.

We are in the business of growing your business

Panel Warning Light

This attractive 2" round escutcheon plate has an adhesive back for easy panel mounting.

The green warning L.E.D. provides constant monitoring of the system to comply with U.S. Coast Guard requirements for system approval. Standard with all CG2 and MA2 fire extinguishing systems.

PART#	DESCRIPTION
FBLKIT	Fire System Status Indicator Light w/Panel

Discharge Cable Kits

MA2 Series discharge cable for those who prefer a way to activate the system faster than the response time of the bulb head or for inspected vessels required to by US and Canadian Coast Guard regulations. The kit includes cable, escutcheon plate, pull handle, safety pin and safety tie.

NOTE: Discharge cable from 32 feet to 50 feet are available on special order. Minimum four (4) weeks delivery.

PART#	DESCRIPTION
E42096	Manual Discharge Cable, 6'
E42098	Manual Discharge Cable, 8'
E420910	Manual Discharge Cable, 10'
E420912	Manual Discharge Cable, 12'
E420914	Manual Discharge Cable, 14'
E420916	Manual Discharge Cable, 16'
E420918	Manual Discharge Cable, 18'
E420920	Manual Discharge Cable, 20'
E420922	Manual Discharge Cable, 22'
E420924	Manual Discharge Cable, 24'
E420926	Manual Discharge Cable, 26'
E420928	Manual Discharge Cable, 28'
E420930	Manual Discharge Cable, 30'



Manual Discharge Cable

Automatic Shut-Down Systems

Available for shutting down up to eight circuits with engine circuit relays featuring an operating range of 100mA to 10 amps. Available in either 12VDC or 24VDC models providing shutdown capability for up to 8 different engines. Each engine shutdown display unit comes with an integrated alarm horn, charged / discharged lights and an override switch for restart or control of auto-shutdown.

PART#	DESCRIPTION
ES300001	Diesel Engine Shut Down 12VDC, 3-Circuit
ES500001	Diesel Engine Shut Down 12VDC, 5-Circuit



Engine Shut Down

FIRE EXTINGUISHERS



MIX EXTINGUISHER BRANDS AND MODELS FOR BEST QUANTITY PRICING

Strike First ABC Multi-Purpose Extinguishers

Strike First's ULC Listed ABC extinguishers are built tough and easy to service. They provide effective protection against fires involving electrical equipment, Class A wood, paper, cloth and Class B flammable liquids.

- Steel cylinder complete with protective skirt
- Super durable polyester powder paint finish with superior corrosion resistance
- Universal valve body featuring the new pin style wall hook
- Stainless steel handles - with reinforced bottom handle
- GHS info integrated into label (replaces WHMIS in Canada)
- Oversized stainless steel pull pin with retaining strap for easier and faster activation.
- Temperature Range -65°F to 120°F (-54°C - 49°C)
- 6 Year Limited Warranty



PART#	DESCRIPTION	ULC RATING	SKID QTY
SF-ABC110	2½ lb. ABC w/ vehicle bracket	1A:10BC	300
SF-ABC310WH	5 lb. ABC w/ wall hanger	3A:10BC	200
SF-ABC310VB	5 lb. ABC w/ vehicle bracket	3A:10BC	200
SF-ABC340WH	5 lb. ABC w/ wall hanger	3A:40BC	200
SF-ABC340VB	5 lb. ABC w/ vehicle bracket	3A:40BC	200
SF-ABC680	10 lb. ABC w/ wall hanger	6A:80BC	120
SF-ABC1020	20 lb. ABC w/ wall hanger	10A:120BC	50
SF-ABC30	30 lb. ABC w/ wall hanger	10A:120BC	25

Skid Qty pricing available. Refer to Skid Qty column for detail and call for pricing.

Chrome

PART#	DESCRIPTION	ULC RATING
SF-ABC110-CH	2½ lb. ABC w/ vehicle bracket, CHROME	1A:10BC
SF-ABC340WH-CH	5 lb. ABC w/ wall hanger, CHROME	3A:40BC
SF-ABC340VB-CH	5 lb. ABC w/ vehicle bracket, CHROME	3A:40BC

ATTRIBUTE	SPECIFICATION					
Model No.	SF-ABC110	SF-ABC310	SF-ABC340	SF-ABC680	SF-ABC1020	SF-ABC30
ULC Rating	1A:10BC	3A:10BC	3A:40BC	6A:80BC	10A:120BC	10A:120BC
Agent Capacity	2.5 lbs ABC	5 lbs ABC	5 lbs ABC	10 lbs ABC	20 lbs ABC	30 lbs ABC
Discharge Time	9 sec	13 sec	13 sec	15 sec	28 sec	28 sec
P.S.I.	150	195	195	235	235	195
Agent Flow Rate	0.28 lbs/sec	0.31 lbs/sec	0.31 lbs/sec	0.67 lbs/sec	0.72 lbs/sec	1.07 lbs/sec
Range	8-10 ft	8-10 ft	8-10 ft	10-15 ft	10-15 ft	10-15 ft
Shipping Weight (lbs)	4¾	10½	10½	19¼	35¼	50½
Height	15¼"	14½"	16"	21¼"	24"	30¾"
Shell Dia.	3⅝"	4¼"	4¼"	5⅝"	7⅝"	7⅝"
Std Bracket	Vehicle / Marine	Wall or Vehicle / Marine	Wall or Vehicle / Marine	Wall	Wall	Wall
Heavy Duty Bracket	-	VB4	VB4	VB5	VB8	VB8
Chrome Option	YES		YES			

We are in the business of growing your business


MIX EXTINGUISHER BRANDS AND MODELS FOR BEST QUANTITY PRICING
Strike First Regular (BC) Extinguishers

Strike First's ULC Listed **BC** extinguishers are built tough and easy to service. They provide effective protection against fires involving electrical equipment and Class B flammable liquids.

- Steel cylinder complete with protective skirt
- Super durable polyester powder paint finish with superior corrosion resistance
- Waterproof stainless steel gauge
- Reinforced, full grip steel handles with polyester powder paint finish
- Oversized stainless steel pull pin with retaining strap for easier and faster activation
- Temperature Range -65°F to 120°F (-54°C - 49°C)
- 6 Year Limited Warranty



WBDL275BC



WBDL5



WBDLSB10



WBDLSB20

PART#	DESCRIPTION	ULC RATING
WBDL275BC	2¾ lb. BC w/ vehicle bracket	10BC
WBDL5BCWH	5 lb. BC w/ wall hanger	10BC
WBDL5BCVB	5 lb. BC w/ vehicle bracket	10BC
WBDLSB10WH	10 lb. BC w/ wall hanger	60BC
WBDLSB20WH	20 lb. BC w/ wall hanger	80BC

ATTRIBUTE	SPECIFICATION			
Model No.	WBDL275BC	WBDL5BC	WBDLSB10	WBDLSB20
ULC Rating	10BC	10BC	60BC	80BC
Agent Capacity	2.75 lbs BC	5 lbs BC	10 lbs ABC	20 lbs BC
Discharge Time	9 sec	13 sec	15 sec	28 sec
P.S.I.	150	195	235	235
Agent Flow Rate	0.31 lbs/sec	0.31 lbs/sec	0.67 lbs/sec	0.72 lbs/sec
Range	8-10 ft	8-10 ft	10-15 ft	10-15 ft
Shipping Weight (lbs)	4¾	10½	19¼	35¼
Height	15¼"	14½"	21¼"	24"
Shell Dia.	3⅝"	4¼"	5⅝"	7⅝"
Std Bracket	Vehicle / Marine	Wall or Vehicle / Marine	Wall	Wall
Heavy Duty Bracket	-	VB4	VB5	VB8



MIX EXTINGUISHER BRANDS AND MODELS FOR BEST QUANTITY PRICING

Strike First CO2 Extinguishers

Strike First's ULC Listed CO2 extinguishers provide effective protection against fires involving electrical equipment and Class B flammable liquids. CO2 is a clean, environmentally friendly gas that leaves no messy residue to clean up.

- Extinguisher material and construction is well suited for corrosive environments.
- Super durable polyester powder paint finish with superior corrosion resistance
- Industrial strength aluminum cylinder is up to 30% lighter than steel
- Stainless steel handles, pull pin, retaining chain and hose band
- Chrome-plated solid brass valve
- Strong impact resistant horn
- Temperature range: -22°F to 120°F (-30°C to 49°C)
- 5 Year Limited Warranty



SF5C02



SF15C02



SF20C02

PART#	DESCRIPTION	ULC RATING
SF5C02	5 lb. CO2 w/ wall hanger	5BC
SF10C02	10 lb. CO2 w/ wall hanger	10BC
SF15C02	15 lb. CO2 w/ wall hanger	10BC
SF20C02	20 lb. CO2 w/ wall hanger	10BC

ATTRIBUTE	SPECIFICATION			
Model No.	SF5C02	SF10C02	SF15C02	SF20C02
ULC Rating	5BC	10BC	10BC	10BC
Agent Capacity	5lbs CO2	10lbs CO2	15lbs CO2	20lbs CO2
Discharge Time	10 sec	10 sec	15 sec	20 sec
Agent Flow Rate	0.5 lbs/sec	1 lbs/sec	1 lbs/sec	1 lbs/sec
Range	6-12 ft	6-12 ft	6-12 ft	6-12 ft
Shipping Weight (lbs)	13½	28	37	48½
Height	17¼"	19¾"	26¼"	26¼"
Shell Dia.	5¼"	7"	7"	8"
Std Bracket	Wall	Wall	Wall	Wall
Heavy Duty Bracket	VB5	VB8	VB8	VB9

We are in the business of growing your business



MIX EXTINGUISHER BRANDS AND MODELS FOR BEST QUANTITY PRICING

Strike First Pressure Water Extinguisher

Strike First's ULC Listed **Pressure Water** extinguisher is an ideal choice for Class A fire hazards like wood paper and cloth fires. The powerful stream of water allows it to reach areas other extinguishers cannot.

NOTE: Pressure Water extgrs are shipped empty

- Polished stainless steel cylinder complete with protective skirt
- Chrome-plated solid brass valve
- Waterproof stainless steel gauge
- Stainless steel handles and siphon tube
- Oversized stainless steel pull pin with retaining strap for easier and faster activation
- Schrader valve for pressurizing
- Temperature range: 40°F to 120°F (4°C to 49°C)
- 5 Year Limited Warranty
- NOTE: Pressure Water extgrs are shipped empty

PART#	DESCRIPTION	ULC RATING
WBDLPW250	2.4 Gal. (9L) Pressure Water w/wall hanger	2A

PART#	DESCRIPTION
AC40	Anti-Freeze Charge (1 per Extgr) Suitable for -40°F -120°F

!! Water and extinguishers are shipped empty.

ATTRIBUTE	SPECIFICATION
Model No.	WBDLPW250
ULC Rating	2A
Agent Capacity	2.4 Gal. (9L)
Discharge Time	40 sec
P.S.I.	100
Range	40 ft
Shipping Weight (lbs)	8
Height	25"
Shell Dia.	7½"
Std Bracket	Wall
Heavy Duty Bracket	VB8



WBDLPW250



AC40



MIX EXTINGUISHER BRANDS AND MODELS FOR BEST QUANTITY PRICING

Strike First Class K (Kitchen) Extinguisher

Strike First's ULC Listed **Class K** extinguisher is designed for use on restaurant or commercial cooking appliances. The low Ph wet chemical agent effectively smothers and cools fires involving combustible cooking oil (vegetable) or animal fat. It is intended to be used as a back-up for an automatic fire suppression system.

- Polished stainless steel cylinder complete with protective skirt
- Chrome-plated solid brass valve
- Stainless Steel Wall hanger
- Waterproof stainless steel gauge
- Stainless steel handles and siphon tube
- Oversized stainless steel pull pin with retaining strap for easier and faster activation
- Factory filled and pressurized
- Temperature range: 35°F to 120°F (2°C to 49°C)
- 5 Year Limited Warranty

PART#	DESCRIPTION	ULC RATING
FFSF6LK	6L K Class w/wall hanger	1AK

PART#	DESCRIPTION
RP189	K Class Fire Extinguisher Bilingual, Rigid Plastic Sign
SF6LK	Strike First 6 L K-Class Recharge

ATTRIBUTE	SPECIFICATION
Model No.	WBDL6LK
ULC Rating	1AK
Agent Capacity	6L
Discharge Time	55 sec
P.S.I.	100
Range	8-10 ft
Shipping Weight (lbs)	24½
Height	21½"
Shell Dia.	7½"
Std Bracket	Wall
Heavy Duty Bracket	VB8



WBDL6LK



RP189



SF6LK

STRIKE FIRST HEAVY DUTY EXTINGUISHER CART

Strike First's Heavy duty cart helps transporting Strike First 30 lb extinguishers (only) around a site a breeze.

Note: Works with Strike First Extinguishers Only.

- Durable polyester powder paint finish
- Heavy gauge steel construction
- Stainless steel pull pins w/ retaining straps
- Solid 10" rubber wheels
- Safely transports larger, heavier Extinguishers
- Works with Strike First Extgrs Only

PART#	DESCRIPTION
HDCART	30 lb. Strike First ABC heavy duty wheeled cart



HDCART

We are in the business of growing your business


MIX EXTINGUISHER BRANDS AND MODELS FOR BEST QUANTITY PRICING

Amerex ABC Multi-Purpose Extinguishers

Amerex's ULC Listed **ABC** or Multi-Purpose extinguishers utilize a specially fluidized and siliconized mono ammonium phosphate dry chemical. It chemically insulates Class A fires by melting at approximately 350°F and coats surface to which it is applied. It smothers and breaks the chain reaction of Class B fires and will not conduct electricity back to the operator.

- 6 Year Warranty
- Stored Pressure Design
- Dependable Drawn Steel Cylinders
- Durable High Gloss Polyester Powder Paint
- Temperature Range -65°F to 120°F (-54°C - 49°C)
- Aluminum Valve Models feature Anodized Aluminum Valve Body, Anodized Aluminum Handle & Lever
- Brass Valve Models feature: Chrome Plated Brass Valve Body, Stainless Steel Handle & Lever



B417TX



B500



B402



B402TXC



B456



A411



692

PART#	DESCRIPTION	ULC RATING	SHIP WGT. LBS.	UNIT HEIGHT	SHELL DIA.	HEAVY-DUTY BRACKET P/N
B417TX	2½ lb. w/ vehicle bracket	1A:10BC	5½	15½"	3"	-
B417TXC	2½ lb. w/ vehicle bracket, CHROME	1A:10BC	5½	15½"	3"	-
B500X	5 lb. w/ wall hook	3A:10BC	9¼	15¼"	4¼"	VB4
B500TX	5 lb. w/ vehicle bracket	3A:10BC	9½	15¼"	4¼"	VB4
B402TXC	5 lb. w/ vehicle bracket, CHROME	3A:10BC	9½	15¼"	4¼"	VB4
B402X	5 lb. w/ wall hook	3A:40BC	9¼	15¼"	4¼"	VB4
B402TX	5 lb. w/ vehicle bracket	3A:40BC	9½	15¼"	4¼"	VB4
B456X	10 lb. w/ wall hook	4A:80BC	18	20"	5"	VB5
A411X	20 lb. w/ wall hook	10A:120BC	38	23¼"	7"	VB8
692X	30 lb. w/ wall hook, Brass Valve	10A:120BC	49	26½"	8"	VB9



MIX EXTINGUISHER BRANDS AND MODELS FOR BEST QUANTITY PRICING

Amerex Regular (BC) Extinguishers

Amerex's ULC Listed **BC (Regular)** extinguishers. These extinguishers contain a siliconized sodium bicarbonate based dry chemical with free flowing and non-caking additives. Economical Class B & C protection with lower initial cost and recharging. This chemical smothers fires in flammable liquids and pressurized gases and will not conduct electricity back to the operator.

- 6 Year Warranty
- Stored Pressure Design
- Dependable Drawn Steel Cylinders
- Durable High Gloss Polyester Powder Paint
- Temperature Range -65°F to 120°F (-54°C - 49°C)
- Aluminum Valve Models feature Anodized Aluminum Valve Body, Anodized Aluminum Handle & Lever
- Brass Valve Models feature: Chrome Plated Brass Valve Body, Stainless Steel Handle & Lever

PART#	DESCRIPTION	ULC RATING	SHIP WGT. LBS.	UNIT HEIGHT	SHELL DIA.	HEAVY-DUTY BRACKET P/N
B403TX	2½ lb. w/ vehicle bracket	10BC	5½	15½"	3"	-
B459X	5 lb. w/ wall hook	40BC	9½	15¼"	4¼"	VB4
B447X	10 lb. w/ wall hook, Brass Valve	60BC	18	20"	5"	VB5
408X	20 lb. w/ wall hook, Brass Valve	120BC	38	23¼"	7"	VB8



Amerex PK (Purple K) Extinguishers

Amerex's ULC Listed **PK (Purple K)** extinguishers contain specially fluidized and siliconized potassium bicarbonate dry chemical which is particularly effective on Class B flammable liquids and pressurized gases. It is electrically non-conductive. Purple K has been the choice of oil, gas, chemical and utilities industries as the preferred fire-fighting agent.

- 6 Year Warranty
- Stored Pressure Design
- Dependable Drawn Steel Cylinders
- Durable High Gloss Polyester Powder Paint
- Temperature Range -65°F to 120°F (-54°C - 49°C)
- Aluminum Valve Models feature Anodized Aluminum Valve Body, Anodized Aluminum Handle & Lever
- Brass Valve Models feature: Chrome Plated Brass Valve Body, Stainless Steel Handle & Lever

PART#	DESCRIPTION	ULC RATING	SHIP WGT. LBS.	UNIT HEIGHT	SHELL DIA.	HEAVY-DUTY BRACKET P/N
B479T	5 lb. w/ vehicle bracket	30BC	9½	15¼"	4¼"	VB4
B460	10 lb. w/ wall hook, Brass Valve	80BC	19	20½"	5"	VB5
415	20 lb. w/ wall hook, Brass Valve	120BC	39	24"	7"	VB8
693X	30 lb. w/ wall hook, Brass Valve	160BC	58	26½"	8"	VB9





MIX EXTINGUISHER BRANDS AND MODELS FOR BEST QUANTITY PRICING

Amerex CO2 Extinguishers

Amerex's ULC Listed **CO2** extinguishers provide effective protection against fires involving electrical equipment and Class B flammable liquids. CO2 is a clean, environmentally friendly gas that leaves no messy residue to clean up.

Model 322NM Independently Tested and Approved for use in **MRI Facilities** to 7 Tesla. The Model 322NM has a sanitary white paint finish (easy to clean).

- 5 Year Limited Warranty
- All Metal Valve Construction
- Rust free aluminum cylinders
- Durable High Gloss Polyester Powder Paint
- Temperature Range -22°F to 120°F
- Model 322NM Independently Tested and Approved for use in MRI Facilities to 7 Tesla

PART#	DESCRIPTION	ULC RATING	SHIP WGT. LBS.	UNIT HEIGHT	SHELL DIA.	HEAVY-DUTY BRACKET P/N
322X	5 lb. CO2 w/ wall hook	5BC	14	17¾"	5¼"	VB5
322NM	5 lb. CO2 Non-Magnetic w/wall hook	5BC	14	17¾"	5¼"	-
330X	10 lb. CO2 w/ wall hook	10BC	28½	24"	7"	VB8
331X	15 lb. CO2 w/ wall hook	10BC	38	30"	7"	VB8
332X	20 lb. CO2 w/ wall hook	10BC	51	30"	8"	VB9



AMEREX CO2



322NM

Amerex Wheeled CO2

Large volume CO2 protection provided in either 50 or 100 lb. (2 – 50 lb. cylinders) ULC Listed wheeled extinguishers. Rugged construction and easy to operate with a "quick opening" 'T' handle valve and horn mounted shut-off valve. A logical choice in areas where a Class B:C non-contaminating agent is required and where hand portable extinguishers do not provide adequate protection.

- Heavy Duty Steel Carriages
- Quick Opening Brass Valve
- Squeeze Grip Chrome Plated Discharge Valve
- Reinforced Wire Braided Hose and Shock Resistant Horn to Reduce Static Electricity
- Brass Hose Fittings
- DOT/TC Cylinder with Quick Opening Brass Valve
- Clean, Non-Contaminating Odorless Gas
- 5 Year Warranty

PART#	DESCRIPTION	ULC RATING	SHIP WGT. LBS.	UNIT HEIGHT	SHELL DIA.	HEAVY-DUTY BRACKET P/N
333	50 lb. CO2, Wheeled	20BC	257	47"	23"	48"
334	100 lb. CO2, Wheeled	20BC	461	47"	23"	48"



333



334



MIX EXTINGUISHER BRANDS AND MODELS FOR BEST QUANTITY PRICING

Amerex Pressure Water and Foam Extinguishers

Model 240 Water utilizes the cooling, soaking and penetrating effect of a 45-55 ft stream of water. The 55 sec. discharge time makes it very effective for inexperienced operators for use on Class A fires.

Model 254 AR-AFFF FOAM unique 6 liter size fills many requirements for a lighter, more compact Class A:B extinguisher. Easy and effective application with the spray nozzle. Apply to Class B liquid spills to prevent ignition. Ideal for emergency first response vehicles.

Model 250 AR-AFFF FOAM Class A:B extinguisher. Easy and effective application with air aspirated nozzle. Apply to Class B liquid spills to prevent ignition. Ideal for emergency first response vehicles.

!! Water and Foam extinguishers are shipped empty. Foam charge is included with extinguisher.

- 5 Year Manufacturer's Warranty
- Stored Pressure Design
- Polished Stainless Steel Cylinders
- All Metal Valve Construction
- Exclusive crevice free, butt welded cylinders
- Temperature Range +40°F to 120°F
- Clean, no powder residue



PART#	DESCRIPTION	ULC RATING	SHIP WGT. LBS.	UNIT HEIGHT	SHELL DIA.	HEAVY-DUTY BRACKET P/N
240X	2½ Gal. Pressure Water w/wall hook	2A	7½	24½"	7"	VB8
250X	2-1/2 Gal. AR-AFFF w/ wall hook	3A:20B	11	24½"	7"	VB8

PART#	DESCRIPTION
AC40	Anti-Freeze Charge (1 per Extgr) Suitable for -40°F -120°F
A2117	AR-AFFF foam recharge for 254, 250X (Replaces A502 and A504 Premix Charge)



!! Water and Foam extinguishers are shipped empty. Foam charge is included with extinguisher.

Amerex Wheeled AR-AFF Foam

The **Model 630** contains a premixed alcohol resistant AR-AFFF foam which is highly effective on Class B fuel fires and a penetrating and wetting agent on fires involving Class A materials. Excellent when used as a vapor suppressant on fuel spills to prevent ignition. Quality hardware throughout including the unique agent cylinder fabricated entirely of stainless steel - no interior coatings are necessary. Model 630 meets NFPA 418 requirements for H-1 category helicopter pad protection.

- Stainless Steel Collars
- Standard with Anti-Static Rubber Tires
- Chrome Plated Brass Fill Caps
- Brass Hose Fittings
- Live Swivels on Discharge Valve
- Heavy Duty Steel Cylinder, Carriage, Hose Rack
- DOT/TC Nitrogen Cylinder with Quick Opening Brass Valve
- 5 Year Warranty

PART#	DESCRIPTION	ULC RATING	SHIP WGT. LBS.	UNIT HEIGHT	UNIT WIDTH	UNIT DEPTH
630RT	33 Gal. AR-AFFF w/ rubber wheels	20A:160B	390	57	34	39



Note: Unit shown without the rubber wheels



MIX EXTINGUISHER BRANDS AND MODELS FOR BEST QUANTITY PRICING

Amerex Class K (Kitchen) Extinguisher

Amerex's ULC Listed **Class K** wet chemical extinguishers are the best restaurant kitchen appliance hand portable fire extinguishers you can purchase. Each model has been tested and approved for the Class K listing by ULC specifically for restaurant kitchen hazards. They contain a special potassium acetate based agent. The recent trend to more efficient cooking appliances and use of vegetable based cooking oils dictates the use of a hand portable fire extinguisher with greater fire-fighting capacity and cooling effect to combat these very hot and difficult fires. They supplement existing cooking equipment automatic system protection for an extra margin of safety.

- 5 Year Limited Manufacturer's Warranty
- Polished Stainless Steel Cylinders
- All Stainless Steel Valve Construction
- Tested on Commercial Deep Fat Fryers to ANSI / UL Safe to use on Energized Electric Appliances
- Class 2A Rated to Meet Fire Code Occupancy Hazard Requirements
- Temperature Range +40°F to 120°F
- Large Loop Stainless Steel Pull Pin
- Swivel Connection on Hose Allows Nozzle to be Oriented for Proper Use
- Nozzle Grip Design with 45° Angle for Easy "Overhead" Application
- Agent Discharged as a Fine Mist Helps Prevent Grease Splash and Re-flash While Cooling the Appliance



B260X



RP189



AX530

PART#	DESCRIPTION	ULC RATING	SHIP WGT. LBS.	UNIT HEIGHT	SHELL DIA.	HEAVY-DUTY BRACKET P/N
B260X	6 Litre Wet Chemical (K Type) (shipped charged)	1AK	16	19"	7"	VB8
RP189	K Class Fire Extinguisher Bilingual, Rigid Plastic Sign					
AX530	6 Litre recharge for B260X					

Amerex Water Mist

WATER MIST is the ultimate extinguisher for Class A fires and where a potential Class C (electrical) hazard exists. The fine spray from the unique misting nozzle provides safety from electrical shock, greatly enhances the cooling and soaking characteristics of the agent and reduces scattering of burning materials. The **Amerex Water Mist** extinguishers **contain deionized water (sold separately)** making them the best extinguishers for protection of hospital environments, valuable books and documents, telecommunication facilities and "clean room" manufacturing facilities. The Amerex Water Mist extinguishers are easy to use, maintain, and service. **Safe to use in MRI facilities and on energized equipment.**

- Stainless Steel Cylinders
- Durable High Gloss Polyester Powder Paint
- All Metal Valve Construction
- Temperature Range +40°F to 120°F
- MRI SAFE - Nonmagnetic Construction Tested by an Independent Agency for use in MRI Facilities to 7 Tesla (including wall hanger bracket)
- Non-toxic - Causes no Respiratory Problems
- Uses Deionized Water Extinguishing Agent (sold separately)
- Sanitary White Paint Finish (easy to clean)
- Wand Provides Greatest Operator Safety
- Large Loop Stainless Steel Pull Pin
- No Electrical Conductivity Back to the Operator
- No Thermal or Static Shock



B272XN

PART#	DESCRIPTION	ULC RATING	SHIP WGT. LBS.	UNIT HEIGHT	SHELL DIA.	HEAVY-DUTY BRACKET P/N
B272XN	2½ Gal. Water Mist w/wall hook (charge sold separately)	2A:C	8	24½"	7"	VB8
A671	2½ Gal. deionized water charge for B272XN					

!! Water mist shipped empty. Deionized Water Mist charge sold separately.



MIX EXTINGUISHER BRANDS AND MODELS FOR BEST QUANTITY PRICING

Amerex Class D Extinguishers

MODEL B570 contains a special blended Sodium Chloride (salt) based dry powder extinguishing agent. Metal fires involving magnesium, sodium, potassium and sodium-potassium alloys can be successfully extinguished with this extinguisher. There is data showing that zirconium, uranium, titanium, and powdered aluminum fires can be controlled and extinguished with this unique extinguisher.

Extinguishing Capacity Model B570X

- Magnesium Chips: 4 ft 2" and/or 6 lbs. of metal
- Sodium or Potassium Spill: 5 ft 2" and/or 5 lbs. of metal
- Sodium or Potassium Spill Depth Over 1/2": 3 ft 2" and or 6 lbs. of metal
- Sodium Potassium Alloy Spill: 3 ft 2" and/or 2 lbs. of metal

MODEL B571 contains a copper extinguishing agent specially developed by the U.S. Navy for fighting lithium and lithium alloy fires. The copper compound smothers the fire and provides an excellent heat sink for dissipating heat. Copper powder has been found to be superior to all other known fire extinguishing agents for lithium.

Extinguishing Capacity Model B571

- 4 ft 2" and/or 5 lbs. of lithium
- 6 Year Warranty
- Dependable Drawn Steel Cylinders
- Special corrosion resistant yellow (Class D) color coded paint finish
- All Metal Valve Construction
- Temperature Range -40°F to 120°F
- Unique "soft flow" extension applicator plus built in long range nozzle
- Large Loop Stainless Steel Pull Pin



B570X / B571

PART#	DESCRIPTION	ULC RATING	SHIP WGT. LBS.	UNIT HEIGHT	SHELL DIA.	HEAVY-DUTY BRACKET P/N
B570X	30 lb. Class D w/ wall hook (Salt)	D	53	35	8"	VB9
B571	30 lb. Class D w/ wall hook (Copper)	D	53	35	8"	VB9

Wheeled Class D Units available.



MIX EXTINGUISHER BRANDS AND MODELS FOR BEST QUANTITY PRICING

Amerex Halotron Extinguishers

Halotron™ I clean fire extinguishing agent discharges as a rapidly evaporating liquid, which is non-conductive, non-corrosive, and leaves behind no residue. The Halotron™ I clean agent has been determined to be the most environmentally beneficial halocarbon agent on the market today that meets wide performance standards. The primary raw material in the agent is HCFC-123, which has an outstanding profile of near-zero ozone depleting potential and a low global warming potential. Ideal applications for these extinguishers include: data centers, laboratories, manufacturing plants, general office areas, computer rooms, telecommunication facilities, clean rooms, control rooms, warehouses, military electronics, vehicles including classic autos, boats, engine compartments, aircraft ramps, onboard aircraft and in facilities that service aircraft and any facility where dry chemical extinguishers could cause unacceptable damage or contamination.

- 6 Year Limited Manufacturer's Warranty
- Dependable Drawn Steel Cylinders
- Durable High Gloss Polyester Powder Paint
- All Metal Valve Construction
- Temperature Range -40°F to 120°F
- EPA approved "Clean Agent" for Class A, Band C hazards
- Low GWP (Global Warming Potential)
- Low ODP (Ozone Depletion Potential)
- Short Atmospheric Lifetime
- Leaves No Residue
- Large Loop Pull Pin
- No Electrical Conductivity Back to the Operator
- No Thermal or Static Shock



B384T



B385TS



B386T



397



398

PART#	DESCRIPTION	ULC RATING	SHIP WGT. LBS.	UNIT HEIGHT	SHELL DIA.	HEAVY-DUTY BRACKET P/N
A384T	1.4 lb. Halotron w/ vehicle bracket	1BC	3.25	10"	2.63"	-
B385TS	2½ lb. Halotron w/ vehicle bracket	2BC	5¼	15½"	3"	-
B386T	5 lb. Halotron w/ vehicle bracket	5BC	9½	15¼"	4¼"	VB4
397	11 lb. Halotron w/ wall hook	1A:10BC	22½	21.88"	6"	VB6
398	15½ lb. Halotron w/ wall hook	2A:10BC	27½	21.88"	6"	VB6

Amerex Wheeled NOVEC 1230

3M™ NOVEC 1230™ Fire Protection Fluid has a Global Warming Potential of 1 and an atmospheric life of just 5 days making it the long term sustainable choice that also has the greatest margin of safety of any of the chemical agents in the marketplace today.

- Environmentally friendly 3M™ Novec™ 1230 Clean Agent (0 ODP - 1 GWP)
- Brass, chrome plated operating valve
- 125 PSI Operating Pressure
- Heavy duty steel cylinder, carriage and hose hanger assembly
- DOT Cylinders
- Quick release 40 ft. discharge hose with brass/chrome plated ball type shut-off nozzle
- Pressure gauge protected by a stainless steel gauge guard
- Corrosion resistant lime/yellow polyurethane paint finish
- Operating temperature range: -40° to +120° F
- 6 year manufacturer's warranty

PART#	DESCRIPTION	ULC RATING	SHIP WGT. LBS.	UNIT HEIGHT	UNIT WIDTH	UNIT DEPTH
775X	150 lb. Novec 1230 w/ 16" wheels	3A:80BC	395	61	29	42



775X

Steel Fire 800.387.9555



MIX EXTINGUISHER BRANDS AND MODELS FOR BEST QUANTITY PRICING

Amerex Halotron I Wheeled

The **Amerex Halotron I™** wheeled extinguishers feature the same qualities found in all Amerex products and adds the convenience of a “clean” extinguishing agent. Halotron I™ extinguishing agent has proven itself as the leader in the hunt for an alternative “clean” agent by being the only alternative “clean” agent to obtain FAA approvals for both ramp use (ARFF Vehicle) and on-board an aircraft. Combining the quality of Amerex products with a proven alternative “clean” agent, the Amerex Halotron I™ wheeled extinguishers offer you the best value in the industry.

- Brass Hose Fittings
- Live Swivels on Discharge Valve
- Reflective stripes
- Tow loops
- Stainless Steel Fasteners
- Heavy Duty Steel Cylinder, Carriage, Hose Rack
- DOT/TC Cylinders
- Stainless Steel Gauge Guard
- Quick Opening Valves
- Chrome Plated Brass Valve
- Quick Release Discharge Hose
- 6 Year Warranty



673



674

PART#	DESCRIPTION	ULC RATING	SHIP WGT. LBS.	UNIT HEIGHT	UNIT WIDTH	UNIT DEPTH
673	65 lb. Halotron	4A:80BC	286	58	28	39
674	150 lb. Halotron w/ 16” wheels	10A:120BC	512	64	30	42

Amerex Wheeled Stored Pressure Dry Chemical

These commercial stored pressure extinguishers are available in a choice of two sizes and three chemical options. The carriage design on both sizes provides cage type protection for the agent cylinder as well as a well-balanced platform for transportation and operation. The narrow width and easy rolling semi-pneumatic rubber tire wheels allow one-person movement through narrow aisles, doorways and in confined areas. Chemical and pressure is sealed in the agent cylinder, ready for instant actuation and is always protected from contamination. Stored pressure wheeled extinguishers are less expensive to purchase as well as easier and less costly to maintain and service.

- Brass Hose Fittings
- Quick Opening Valves
- Live Swivel on Discharge Valve
- Brass Valve – Chrome Plated on 125 lb. & 150 lb. Models
- Lifting Eyes on 125 lb. & 150 lb. Models
- Heavy Duty Steel Cylinder, Carriage, Hose Rack
- DOT/TC Cylinders
- Chrome Forged Brass Fill Cap on 125 lb. & 150 lb. Models
- Large fill opening on 125 lb. & 150 lb. Models
- Stainless Steel Fasteners
- Stainless Steel Gauge Guard on 125 lb. & 150 lb. Models
- 6 Year Warranty



495



488

PART#	DESCRIPTION	ULC RATING	SHIP WGT. LBS.	UNIT HEIGHT	UNIT WIDTH	UNIT DEPTH
495	50 lb. ABC 12” wheels	20A:160B:C	174	46”	21½”	24”
488	125 lb. ABC 16” wheels	30A:240B:C	344	53½”	28”	40”
490	125 lb. Purple K 16” wheels	320B:C	344	53½”	28”	40”



MIX EXTINGUISHER BRANDS AND MODELS FOR BEST QUANTITY PRICING

Amerex Direct Pressure Nitrogen Cylinder Operated Wheeled Dry Chemical

125 lb. ABC & Purple K and 150 lb. Regular Direct Pressure extinguishers utilize a 23 ft³ nitrogen cylinder with a “quick opening brass valve” to pressurize and completely discharge the agent cylinder. The compact size and 16” semi-pneumatic tires allow easy maneuvering and operation by one person, through narrow doorways and aisles. A 4” stainless steel fill opening with rugged chrome plated brass cap makes servicing easier. For large hazards choose the 300 lb. ABC or Purple K or 350 lb. Regular Direct Pressure extinguishers with a “quick opening” 55 ft³ nitrogen cylinder. They provide quality and economical fire protection, large volume capacity for extra high hazard areas with single person transport and operation. The 36” X 6” wide steel wheels make movement possible in sandy or soft soil.

- Stainless Steel Collars
- Chrome Plated Brass Fill Caps
- Brass Hose Fittings
- Live Swivels on Discharge Valve
- Heavy Duty Steel Cylinder, Carriage, Hose Rack
- Lifting Eyes
- DOT/TC Nitrogen Cylinder with Quick Opening Brass Valve
- 6 Year Warranty

PART#	DESCRIPTION	ULC RATING	SHIP WGT. LBS.	UNIT HEIGHT	UNIT WIDTH	UNIT DEPTH
450	125 lb. ABC, 16” wheels (23 cu ft cyl)	30A:240B:C	335	45”	24”	36”
452	125 lb. Purple K, 16” wheels (23 cu ft cyl)	320B:C	335	45”	24”	36”
491	300 lb. ABC, 36” Wheels (55 cu ft cyl)	40A:320B:C	743	57”	34”	39”
493	300 lb. Purple K, 36” wheels (55 cu ft cyl)	320B:C	743	57”	34”	39”



452



491

Amerex Regulated Pressure Nitrogen Cylinder Operated Wheeled Dry Chemical

These 110 ft³ nitrogen cylinder operated models feature a pressure regulator and two wheel options. The older, traditional design allows for adequate pressure to assure a smooth, complete discharge of the dry chemical with pressure reserve for blowing down the discharge hose. Choose either the 16” semi-pneumatic rubber tire or 36” X 2½” steel wheels according to the area to be protected. Easy to transport and operate by one person.

- Stainless Steel Collars
- Chrome Plated Brass Fill Caps
- Brass Hose Fittings
- Live Swivels on Discharge Valve
- Heavy Duty Steel Cylinder, Carriage, Hose Rack
- Lifting Eyes
- DOT/TC Nitrogen Cylinder with Quick Opening Brass Valve
- 6 Year Warranty

PART#	DESCRIPTION	ULC RATING	SHIP WGT. LBS.	UNIT HEIGHT	UNIT WIDTH	UNIT DEPTH
467	125 lb. ABC, 16” wheels (110 cu ft cyl)	30A:240B:C	404	52”	26”	38”
469	125 lb. Purple K, 16” wheels (110 cu ft cyl)	320B:C	404	52”	26”	38”
470	300 lb. ABC, 36” wheels (110 cu ft cyl)	30A:320B:C	432	52”	28”	45”
472	125 lb. Purple K, 36” wheels (110 cu ft cyl)	320B:C	432	52”	28”	45”

**Optional rubber tread on steel wheels available.
More wheeled units available.**



467



472



MIX EXTINGUISHER BRANDS AND MODELS FOR BEST QUANTITY PRICING

Ansul Sentry Dry Chemical Extinguishers

SENTRY dry chemical extinguishers are designed for protection of light and ordinary hazards. These compact and portable extinguishers are suited for both industrial and commercial/compliance fire protection needs. All extinguishers are designed to fit most wall mounted storage cabinets. Typical applications include light manufacturing, warehousing, restaurants, office buildings, shop areas, auto repair shops, paint process areas, apartment buildings, parking garages, aircraft servicing areas, material handling vehicles, and many others.

SENTRY Low Profile Model 05S (5 lb.) Stored Pressure Fire Extinguishers. The low profile models feature a reduced total height of 16¾ in. (425 mm) allowing placement in most of the popular compact extinguisher cabinets: CATO Chief 1055, Brooks Mark 1 Jr.

- Dependable Drawn Steel Cylinders
- Tough, glare-resistant, one-piece mylar nameplates
- Valve bodies are made from a durable extruded aluminum alloy
- Choice of **FORAY (ABC)**, **PLUS FIFTY (BC)** and **Purple-K** dry chemical agents to satisfy specific protection requirements
- Large, easy-to-read pressure gauge
- Durable powder coat paint finish for superior corrosion resistance and resistance to blistering, cracking, fading and chipping
- 6 Year Limited Warranty
- Temperature Range -65°F to 120°F (-54°C - 49°C)

ABC DRY CHEMICAL		
PART#	DESCRIPTION	MODEL#
438738	2½ lb FORAY w/ vehicle bracket	A02SVB
442238	5 lb. FORAY, w/ wall hook	A05S
442239	5 lb. FORAY, w/ vehicle bracket	A05SVB
442260	5 lb. FORAY, w/ wall hook	AA05S-1
442261	5 lb. FORAY, w/ vehicle bracket	AA05S-1VB
436509	10 lb. FORAY w/ wall hook	AA10S
434765	20 lb. FORAY w/ wall hook	AA20-1
AN53080	Ansul FORAY (ABC) Dry Chemical, Yellow Label, 45lb Pail	
AN415788	Ansul Special FORAY (ABC) Dry Chemical, 45 lb. Pail (for Models AA05, AA10S, AA20)	



438738 442238 / 442239 442260 / 442261 436509

PURPLE-K "PK" DRY CHEMICAL		
PART#	DESCRIPTION	MODEL#
436791	10 lb. Purple-K w/ wall hook	PK10S
434276	20 lb. Purple-K w/ wall hook	PK20
AN9335	Ansul Purple-K Dry Chemical, 50lb. Pail	



434765 AN53080 AN415788

ATTRIBUTE	SPECIFICATION							
	ABC MULTI-PURPOSE					PURPLE K		
Model No.	A02SVB	A05S / A05SVB	AA05S-1 / AA05S-1VB	AA10S	AA20-1	PK10S	PK20	
ULC Rating	1A:10BC	3A:10BC	3A:40BC	4A:80BC	10A:120BC	80BC	120BC	
Agent Capacity	2.5 lbs ABC	5 lbs ABC	5 lbs ABC	10 lbs ABC	20 lbs ABC	10 lbs PK	20 lbs PK	
Discharge Time	9 sec	15 sec	14 sec	21 sec	28 sec	22 sec	30 sec	
Agent Flow Rate	0.28 lbs/sec	0.33 lbs/sec	0.36 lbs/sec	0.52 lbs/sec	0.73 lbs/sec	0.46 lbs/sec	0.67 lbs/sec	
Max Effective Range	11 ft	14 ft	14 ft	20 ft	22 ft	20 ft	22 ft	
Shipping Weight (lbs)	5	9	9	17	32	18	32	
Height	13¾"	16¾"	16¾"	20½"	22½"	20½"	22½"	
Shell Dia.	3⅝"	4⅞"	4⅞"	5¼"	7⅞"	5¼"	7⅞"	
Std Bracket	Vehicle	Wall / Vehicle	Wall / Vehicle	Wall	Wall	Wall	Wall	
Heavy Duty Bracket	-	VB4	VB4	VB5	VB8	VB5	VB8	



436791

434276

We are in the business of growing your business



MIX EXTINGUISHER BRANDS AND MODELS FOR BEST QUANTITY PRICING

Ansul Sentry High Flow Extinguishers

SENTRY High-Flow, Stored-Pressure Fire Extinguishers are designed specifically for commercial, compliance markets. This portable fire extinguisher provides cost-effective, high performing fire suppression. The quick discharge rate enables the dry chemical agent to reach fires faster, providing increased firefighting capability as compared to a standard fire extinguisher.

Available in 10-pound and 20-pound models with standard or corrosion resistant coatings, the high-flow, stored-pressure fire extinguishers are designed to meet the requirements of NFPA 10 (Standard for Portable Fire Extinguishers) Section 5.5.1.1 **for pressurized flammable liquids, 3D and pressurized gas fires.**

Applications include propane filling and storage locations, gas/fuel stations, construction sites, maintenance facilities, hazardous material cabinets, small paint booths, marinas, salvage/recycling centers and warehouse/storage facilities.

- 240 psi (16.6 bar) operating pressure for maximum
- Dependable Drawn Steel Cylinders
- Tough, glare-resistant, one-piece mylar nameplates with distinct “High-Flow” designation
- Valve bodies are made from a durable extruded aluminum alloy
- Choice of **FORAY (ABC)** and **Purple-K** dry chemical agents to satisfy specific protection requirements
- Large, easy-to-read pressure gauge
- Durable powder coat paint finish for superior corrosion resistance and resistance to blistering, cracking, fading and chipping
- 6 Year Limited Warranty
- **Corrosion-Resistant (CR) models available**
- Temperature Range -65°F to 120°F (-54°C - 49°C)

ABC DRY CHEMICAL

PART#	DESCRIPTION	MODEL#
441337	10 lb. FORAY (ABC) High Flow	HF-AA10S
441349	10 lb. FORAY (ABC) High Flow, CR	CR-HF-AA10S
441334	20 lb. FORAY (ABC) High Flow	HF-AA20-1
441346	20 lb. FORAY (ABC) High Flow, CR	CR-HF-AA20-1

Model Notes: CR = Corrosion Resistant, HF = High Flow

PURPLE-K “PK” DRY CHEMICAL

PART#	DESCRIPTION	MODEL#
441331	10 lb. Purple-K High Flow	HF-PK10S
441343	10 lb. Purple-K High Flow, CR	CR-HF-PK10S
441328	20 lb. Purple-K High Flow	HF-PK20
441340	20 lb. Purple-K High Flow, CR	CR-HF-PK20

Model Notes: CR = Corrosion Resistant, HF = High Flow

ATTRIBUTE	SPECIFICATION			
	ABC MULTI-PURPOSE		PURPLE K	
Model No.	HF-AA10S	HF-AA20-1	HF-PK10S	HF-PK20
ULC Rating	1A:20BC	4A:60BC	20BC	60BC
Agent Capacity	10 lbs ABC	20 lbs ABC	10 lbs PK	20 lbs PK
Discharge Time	9 sec	18.2 sec	8.9 sec	18.2 sec
P.S.I.	240	240	240	240
Agent Flow Rate	1.26 lbs/sec	1.2 lbs/sec	1.3 lbs/sec	1.19 lbs/sec
Max Effective Range	25 ft	30 ft	25 ft	35 ft
Shipping Weight (lbs)	17	32	18	32
Height	20½”	22½”	20½”	22½”
Shell Dia.	5¼”	7¾”	5¼”	7¾”
Std Bracket	Wall	Wall	Wall	Wall
Heavy Duty Bracket	VB5	VB8	VB5	VB8
CR Model Available	Yes	Yes	Yes	Yes



441337

441349



441334

441346



441331

441343

441328

441340



MIX EXTINGUISHER BRANDS AND MODELS FOR BEST QUANTITY PRICING

Ansul Red Line Cartridge Operated Extinguishers

RED LINE dry chemical extinguishers are designed for the protection of ordinary and high risk hazards. This hand portable extinguisher is used in industries where the occurrence or possibility of fire is high. The RED LINE extinguisher has set the standard for reliable fire protection in many industries and applications including refining, petrochemical, oil and natural gas production, mining, transportation, utilities, metal processing, paint process areas, welding areas, material storage areas and many others.

- Rugged, durable, reliable fire protection
- Choice of **FORAY (ABC)**, **PLUS FIFTY (BC)** and **Purple-K** dry chemical agents to satisfy specific protection requirements
- Maintenance checks can be easily made on every moving part
- Field rechargeable
- Standard models are equipped with CO2 cartridges and receivers which are listed and approved for operation in environments with temperatures between -40°F to 120°F (-40°C to 48.8°C).
- Indicator cap comes standard to visually show whether the unit is pressurized
- Twelve-year limited warranty
- Four sizes (5, 10, 20 and 30) available with many model options to suit your needs including Low Temp (Nitrogen Cartridge allowing unit to operate to -65°F (-54°C), corrosion resistant, high flow, metal cartridge guard

PART#	DESCRIPTION	MODEL#
435067	5lb. ABC Cart Op	A-5-1
435091	10 lb. ABC Cart Op	I-A-10-G-1
435104	10 lb. ABC Cart Op, Low Temp	LT-I-A-10-G-1
435115	20 lb. ABC Cart Op	I-A-20-G-1
435132	20 lb. ABC Cart Op, Low Temp	LT-I-A-20-G-1
434546	20 lb. Purple-K Cart Op, Low Temp	LT-I-K-20-G-1
435158	30 lb. ABC Cart Op	I-A-30-G-1
434558	30 lb. Purple-K Cart Op, Low Temp	LT-I-K-30-G-1

Model Notes: A = ABC, I = Indicator Cap, K = Purple-K, LT = Low Temperature (Nitrogen Cartridge)
More cartridge operated models available. Standard models come with CO2 cartridge.

ATTRIBUTE	SPECIFICATION					
	ABC MULTI-PURPOSE				PURPLE K	
Model No.	A-5-1	I-A-10-G-1	I-A-20-G-1	I-A-30-G-1	I-K-20-G-1	I-K-30-G-1
ULC Rating	2A:10BC	4A:40BC	6A:60BC	10A:80BC	80BC	120BC
Agent Capacity	5 lbs ABC	8.5 lbs ABC	17 lbs ABC	25 lbs ABC	18 lbs PK	27 lbs PK
Discharge Time	n/a	15 sec	22 sec	26 sec	21 sec	27 sec
Agent Flow Rate	n/a	0.5 lbs/sec	0.77 lbs/sec	0.89 lbs/sec	0.89 lbs/sec	0.99 lbs/sec
Max Effective Range	n/a	17 ft	20 ft	20 ft	30 ft	30 ft
Shipping Weight (lbs)	12	20.5	35	49.5	36	51.5
Height	18"	16.1"	20½"	22½"	20½"	22½"
Shell Dia.	5½"	4.9"	6"	7"	6"	7"
Std Bracket	Wall	Wall	Wall	Wall	Wall	Wall
Heavy Duty Bracket	AN79758	A10C	AG20C	AG30C	AG20C	AG30C
CR Model Available	No	Yes	Yes	Yes	Yes	Yes
LT Model Available	Yes	Yes	Yes	Yes	Yes	Yes



435067



435091 / 435104



435115 / 435132



434546



435158



434558

We are in the business of growing your business



MIX EXTINGUISHER BRANDS AND MODELS FOR BEST QUANTITY PRICING

Ansul CO2 Extinguishers

Every year, a variety of incidents lead to fires that cost businesses their critical assets. **SENTRY** carbon dioxide extinguishers provide the power to respond quickly and effectively by design to protect against Class B (flammable liquids and gases) and Class C (energized electrical equipment) fires. These extinguishers are well suited for indoor use in furnace rooms, printing presses, pump rooms, electrical power panels, and laboratories where winds and drafts do not affect discharge.

SENTRY CO2 extinguishers are available in lightweight aluminum shells and in capacities ranging from 5 lb to 20 lb. These extinguishers may be used indoors where winds and drafts do not affect discharge or where a clean extinguishing agent is required. The non-corrosive, non-conductive, clean extinguishing agent leaves no residue to clean up. Caution is advised in small, enclosed spaces as CO2 is a clear gas which cools and displaces oxygen.

- Non-corrosive, non-conductive, clean extinguishing agent leaves no residue
- Lightweight aluminum shell
- Durable powder coat paint finish for superior corrosion resistance and resistance to blistering, cracking, fading and chipping
- Operating temperature range is -22°F to 120°F (-30°C to 49°C)
- 6 year limited warranty

PART#	DESCRIPTION	MODEL#
431557	5 lb. CO2 w/wall hook	CD05A-1
431558	10 lb. CO2 w/wall hook	CD10A-1
431559	15 lb. CO2 w/wall hook	CD15A-1
431560	20 lb. CO2 w/wall hook	CD20A-1

ATTRIBUTE	SPECIFICATION			
Model No.	CD05A-1	CD10A-1	CD15A-1	CD20A-1
ULC Rating	5BC	10BC	10BC	10BC
Agent Capacity	5 lbs CO2	10 lbs CO2	15 lbs CO2	20 lbs CO2
Discharge Time	10 sec	10 sec	11 sec	13 sec
Service Pressure	1800 PSI	1800 PSI	1800 PSI	1800 PSI
Max Effective Range	6 ft	6 ft	6 ft	6 ft
Shipping Weight (lbs)	16	29	38	50
Height	19"	21¼"	28"	28"
Shell Dia.	5¼"	6 ²⁹ / ₃₂ "	6 ²⁹ / ₃₂ "	8"
Std Bracket	Wall	Wall	Wall	Wall
Heavy Duty Bracket	VB5	VB8	VB8	VB9



431557 (CD05A)



431558 (CD10A)



431559 (CD15A)



431560 (CD20A)



MIX EXTINGUISHER BRANDS AND MODELS FOR BEST QUANTITY PRICING

Ansul Wheeled CO2

RED LINE Carbon Dioxide Wheeled Fire Extinguishers are designed to protect areas where Class B (flammable liquids and gases) or Class C (energized electrical equipment) fires could occur. They may be used indoors where winds and drafts do not affect discharge or where a clean extinguishing agent is required. These extinguishers provide maximum protection in settings such as aircraft hangars, paint spray booths, quench tanks, and metal tube manufacturing.

Carbon dioxide is a non-corrosive, non-damaging extinguishing agent that leaves no residue after a fire. Carbon dioxide provides its own pressure for discharge, and because it is a gas, it will penetrate and spread to all parts of a hazard. Because carbon dioxide displaces oxygen, appropriate safety measures must be taken to evacuate enclosed areas where discharged.

- Non-corrosive, non-conductive, clean extinguishing agent leaves no residue
- Upright positive on-off operation utilizing the squeeze grip activation, precision machined, chrome plated, forged valves, DOT/TC approved steel cylinder mounted to a wheeled carriage for ease of mobility
- Available in 50 lb (23 kg) and 100 lb (45 kg) models
- Operating temperature range is -22°F to 120°F (-30°C to 49°C)
- One-person operation
- Large 16 in. (41 cm) semi-pneumatic rubber wheels
- 6 year limited warranty

PART#	DESCRIPTION	MODEL#
433539	50 lb. CO2, Wheeled	CD-50-D-1
433540	100 lb. CO2, Wheeled	CD-100-D-1

ATTRIBUTE	SPECIFICATION	
Model No.	CD-50-D-1	CD-100-D-1
ULC Rating	20BC	20BC
Agent Capacity	50 lbs	100 lbs
Discharge Time	35 sec	70 sec
Discharge Hose Length	15 ft	40 ft
Effective Range	10-12 ft	10-12 ft
Shipping Weight (lbs)	255	400
Height	58¾"	57"
Width	20"	29"
Depth	28"	28"



433539 (CD-50-D-1)



433540 (CD-100-D-1)



MIX EXTINGUISHER BRANDS AND MODELS FOR BEST QUANTITY PRICING

Pyrochem Pressure Water

The **PYROCHEM Stainless Steel Water Extinguisher** can be utilized in many Class A hazards such as office environments and industrial locations, as well as warehouse and oxidizing chemical storage areas. The unit features a stainless shell and chrome plated valve. The nameplate features easy to read step-by-step instructions for operating the extinguisher. The Schrader valve allows for easy recharge in the field. Use of fresh, clean water is recommended.

- Squeeze grip, positive on-off operation
- Waterproof stainless steel gauge
- Schrader valve for pressurization
- Brass chrome plated valve
- Stainless steel shell
- Operating Temperature Range +40°F to 120°F (4.5°C to 48.9°C)

PART#	DESCRIPTION	MODEL#
PC552501	2½ Gal. S/S Pressure Water w/wall hook	PWS-25G
AC40	Anti-Freeze Charge (1 per Extgr) Suitable for -40°F -120°F	

!! Water extinguishers are shipped empty.



AC40



PC552501

ATTRIBUTE	SPECIFICATION
Model No.	PWS-25G
ULC Rating	2A
Agent Capacity	2.5 Gal. (9.5L)
Discharge Time	Approx 50 sec
Max Effective Range	35 ft
Shipping Weight (lbs)	9
Height	25½"
Shell Dia.	7"
Std Bracket	Wall
Heavy Duty Bracket	VB8

Ansul Class K (Kitchen) Extinguisher

We are pleased to announce that the **ANSUL K-GUARD** Fire Extinguisher is now **2-A: K rated**. Choose ANSUL K-GUARD as your preferred restaurant fire extinguisher and meet NFPA 10 solid fuel cooking requirements for a firebox size of 5 ft3 or less. This upgraded 2-A rating also means compliance with NFPA 10 fire extinguisher size and placement for Class A Hazards which means you can protect the kitchen area without additional extinguishers needed.

Rated for Class K fires, K-GUARD Fire Extinguishers are designed specifically to fight some of the toughest fires—hot grease, cooking oil and fat fires in the kitchens and food-prep areas of restaurants, convenience stores, food courts, hospitals, school cafeterias and other facilities. Typical appliances that benefit from K-GUARD protection include fryers, griddles, ranges, broilers, char-broilers, woks and more.

K-GUARD extinguishers contain ANSULEX Low pH Liquid Fire Suppressant, a specially formulated, aqueous solution. In addition to knocking down the flame and forming a vapor-securing blanket, ANSULEX agent provides a cooling effect that aids in extinguishment and securement of hot cooking fuels. (ANSUL Low pH agent is used in both the K-GUARD extinguishers and R-102 restaurant fire suppression systems.)

- Wide angle, soft discharge spray pattern
- Factory filled and pressurized
- Contains 1.6 Gallons (6 L) ANSULEX Low pH agent
- Stainless steel bourdon tube gauge
- Stainless steel pick-up tube and strainer
- Operating Temperature Range 20°F to 120°F (-29°C to 49°C)
- UL/ULC rated 2-A:K

PART#	DESCRIPTION	MODEL#
439654	6 Litre Wet Chemical (K Type) (shipped charged)	K01-3
RP189	K Class Fire Extinguisher Bilingual, Rigid Plastic Sign	
79372AS	3 Gal. ANSULEX Low pH Liquid Agent, K01-2, K01-3	



RP189



79372AS



439654

ATTRIBUTE	SPECIFICATION
Model No.	K01-3
ULC Rating	2A:K
Agent Capacity	1.6 Gal. (6L)
Discharge Time	Approx 45 sec
Max Effective Range	8-10 ft
Shipping Weight (lbs)	25
Height	21¼"
Shell Dia.	7"
Std Bracket	Wall
Heavy Duty Bracket	VB8

Steel Fire 800.387.9555



MIX EXTINGUISHER BRANDS AND MODELS FOR BEST QUANTITY PRICING

Ansul Cleanguard FE-36 Extinguishers

CLEANGUARD Clean Agent Extinguishers are designed for the protection of commercial and industrial facilities that typically contain sensitive or irreplaceable equipment and materials that could be damaged or destroyed by water, foam, dry chemical, or carbon dioxide. Offering superior performance, CLEANGUARD extinguishers are electrically nonconductive, environmentally friendly, and extremely low in toxicity. CLEANGUARD extinguishers are ideal for computer centers, data/document storage areas, communications facilities, control rooms, electronics manufacturing, laboratories, museums, art galleries, and more. Rated for Class A, B, and C fires, the extinguisher agent leaves no residue, requires no cleanup after discharge, and will not cause collateral damage to materials, equipment, and facilities.

MODEL FE13NM is tested by Magnetic Resonance Safety Testing Services and shown to be MR Conditional to 3.0 tesla. The extinguisher can be mounted within the **MRI room**.

- Dependable Drawn Steel Cylinders
- Tough, glare-resistant, one-piece mylar nameplates
- Valve bodies are made from a durable extruded aluminum alloy which has been black anodized for additional corrosion resistance
- Large, colour coded easy-to-read pressure gauge
- Durable powder coat paint finish for superior corrosion resistance and resistance to blistering, cracking, fading and chipping
- No clean-up/no residue
- 6 Year Limited Warranty
- Temperature Range -40°F to 120°F (-40°C to 49°C)
- Model FE13NM tested and approved for use in MRI Facilities to 3.0 Tesla (MR Conditional stainless steel shell and MR Conditional valve, hose and nozzle)

PART#	DESCRIPTION	MODEL#
429596	2½ lb. CleanGuard (FE-36) w/ vehicle bracket	FE02VB
442256	4¾ lb. CleanGuard (FE-36) w/ wall hook	FE05S
429598	9½ lb. CleanGuard (FE-36) w/ wall hook	FE09
429599	13¼ lb. CleanGuard (FE-36) w/ wall hook	FE13
433214	13¼ lb. MR Conditional CleanGuard (FE-36) w/ wall hook	FE13NM

ATTRIBUTE	SPECIFICATION				
Model No.	FE02VB	FE05S	FE09	FE13	FE13NM
ULC Rating	2BC	5BC	1A:10BC	2A:10BC	2A:10BC
Agent Capacity	2.5 lbs FE36	4.75 lbs FE36	9.5 lbs FE36	13.25 lbs FE36	13.25 lbs FE36
Discharge Time	9 sec	8.5 sec	9.5 sec	13.5 sec	13.5 sec
Agent Flow Rate	0.28 lbs/sec	0.61 lbs/sec	1 lbs/sec	0.98 lbs/sec	0.98 lbs/sec
Effective Range	8-10 ft	10-12 ft	14-16 ft	14-16 ft	14-16 ft
Shipping Weight (lbs)	5	10	22	26	26
Height	14¼"	16¾"	22	26	26
Shell Dia.	3¾"	4⅞"	7"	7"	7"
Std Bracket	Wall	Wall	Wall	Wall	Wall
Heavy Duty Bracket	-	VB5	VB8	VB8	-
MRI Approved	No	No	No	No	Yes



429596 (FE02VB)



442256 (FE05S)



429598 (FE09)



429599 (FE13)



433214 (FE13NM)



MIX EXTINGUISHER BRANDS AND MODELS FOR BEST QUANTITY PRICING

Ansul Direct Pressure Nitrogen Cylinder Operated Wheeled Dry Chemical

RED LINE MODEL D Wheeled Fire Extinguishers are manufactured to provide protection for hazardous areas where the potential exists for large fires. They can be strategically located to provide maximum protection for a wide variety of hazards, while taking up a minimum of space, and requiring only one trained person for operation.

These extinguishers are available with three types of ANSUL dry chemical suppressing agents giving them the versatility to protect many types of fire hazards.

The wheeled extinguisher is completely self-contained. An attached nitrogen cylinder is the only pressure source required to completely expel the fire suppressing agent. The pressure remaining in the tank after operation is sufficient for cleaning dry chemical from the discharge hose.

Some typical applications include paint spray booths, dip and quench tanks, offshore platforms, loading racks, fuel storage areas, airports, and heavy manufacturing operations.

- Listed by Underwriters Laboratories of Canada (ULC)
- Factory Mutual (FM) and United States Coast Guard (USCG) approved
- Three ANSUL® dry chemical suppressing agents available: PLUS-FIFTY C, FORAY or Purple-K.
- No pressure regulator required, reducing maintenance costs and producing smooth agent flow
- Easy pressurization by turning the nitrogen cylinder hand valve
- Simple operation provided by discharge nozzle with two position ball valve
- Aluminum nozzle barrel provides a solid, round agent stream
- Indicator fill cap pops up red stem when unit is pressurized
- Standard models are listed and approved for operation in environments with temperatures between -40°F to 120°F (-40°C to 48.8°C) * Options: long range nozzle, quick-opening nitrogen cylinder valve, wide wheels, rubber coated tire, low temperature ULC models allowing unit to operate to -65°F (-54°C), and 100 ft (30 m) hose on most models
- Six-year limited warranty



PART#	DESCRIPTION	MODEL#
435052	150 lb. ABC Wheeled Unit, CR	CR-I-A-150-D-1
435054	150 lb. ABC Wheeled Unit, CR, LT	CR-LT-I-A-150-D-1
435060	350 lb. ABC Wheeled Unit, CR, LT	CR-LT-I-A-350-D-1
435334	150 lb. Purple-K Wheeled Unit, CR, LT	CR-LT-I-K-150-D
435338	350 lb. Purple-K Wheeled Unit, CR, LT	CR-LT-I-K-350-D

More wheeled models available

Model Notes: A = ABC, I = Indicator Fill Cap, CR = Corrosion Resistant, K = Purple-K, LT = Low Temperature

ATTRIBUTE	SPECIFICATION				
	ABC MULTI-PURPOSE			PURPLE K	
Model No.	CR-I-A-150-D-1	CR-LT-I-A-150-D-1	CR-LT-I-A-350-D-1	CR-LT-I-K-150-D	CR-LT-I-K-350-D
ULC Rating	30A:240BC	30A:240BC	40A:320BC	320BC	640BC
Agent Capacity	125 lbs ABC	125 lbs ABC	300 lbs ABC	125 lbs PK	300 lbs PK
Discharge Time	49 sec	49 sec	56 sec	51 sec	80 sec
Agent Flow Rate	2.57 lbs/sec	2.57 lbs/sec	5.3 lbs/sec	2.6 lbs/sec	3.8 lbs/sec
Discharge Hose Length	¾ in. x 50 ft	¾ in. x 50 ft	1 in. x 50 ft	¾ in. x 50 ft	1 in. x 50 ft
Effective Range	25 ft	25 ft	30 ft	35 ft	40 ft
Shipping Weight (lbs)	329	329	720	329	692
Height	45½"	45½"	57"	45½"	57"
Width	24"	24"	34"	24"	34"
Depth	36"	36"	47"	36"	47"

Steel Fire 800.387.9555

- **COVERS**
- **CABINETS**
- **ACCESSORIES**



VINYL COVERS

HOSE REEL AND RACK COVERS

Vinyl Hose Reel & Rack Covers

Hose Reel and Rack Reel covers are stenciled on both sides and come with Velcro fastener. Available in English and French. English covers are stenciled "FIRE HOSE KEEP CLEAR, FOR USE BY TRAINED PERSONS ONLY" and French covers are stenciled "BOYAU D'INCENDIE". Fluorescent Red.

PART#	DESCRIPTION	W	H	D	APPLICATION
EHRC18	Hose Reel Cover for 18" Dia. Reel, English	21¾"	19"	5"	Fits HDR18
FHRC18	Hose Reel Cover for 18" Dia. Reel, French	21¾"	19"	5"	Fits HDR18
EHRC24	Hose Reel Cover for 24" Dia. Reel, English	26"	25"	5"	Fits HDR24
FHRC24	Hose Reel Cover for 24" Dia. Reel, French	26"	25"	5"	Fits HDR24
ERHC75	Cover for 75ft Hose Pin Rack, English	21"	24"	5"	Pin racks w/ 75ft hose
FRHC75	Cover for 75ft Hose Pin Rack, French	21"	24"	5"	Pin racks w/ 75ft hose
ERHC100	Cover for 100ft Hose Pin Rack, English	21"	30"	5"	Pin racks w/ 100ft hose
FRHC100	Cover for 100ft Hose Pin Rack, French	21"	30"	5"	Pin racks w/ 100ft hose



EHRC18 / EHRC24



FHRC18 / FHRC24



ERHC75 / ERHC100



FRHC75 / FRHC100

WHEELED UNIT COVERS

Vinyl Wheeled Unit Covers

Vinyl covers for 50, 150 & 350 lb. wheeled units. Durable equipment protection. Helps prevent tampering. Fast and easy to remove. Easy to spot location. Easy to clean. Available in English and French. English covers are stenciled "WHEELED FIRE EXTINGUISHER" and French covers are stenciled "EXTINCTEUR D'INCENDIE". Fluorescent red. Now with straps at bottom corners to allow for bungee cord tie down.

PART#	DESCRIPTION	W	H	D	APPLICATION
EWFE50	50 lb. Wheeled Unit Cover, English	23½"	47½"	16"	Fits 50 lb. Dry Chemical
FWFE50	50 lb. Wheeled Unit Cover, French	23½"	47½"	16"	Fits 50 lb. Dry Chemical
EWFE150	150 lb. Wheeled Unit Cover, English	42"	53"	30"	Fits 150 lb. Dry Chemical
FWFE150	150 lb. Wheeled Unit Cover, French	42"	53"	30"	Fits 150 lb. Dry Chemical
EWFE350	350 lb. Wheeled Unit Cover, English	52"	58"	38"	Fits 350 lb. Dry Chemical
FWFE350	350 lb. Wheeled Unit Cover, French	52"	58"	38"	Fits 350 lb. Dry Chemical
EWFE75	50-75 lb. CO2 Wheeled Unit Cover, English	26"	54"	16"	50 & 75 lb CO2
FWFE75	50-75 lb. CO2 Wheeled Unit Cover, French	26"	54"	16"	50 & 75 lb CO2



EWFE50 / EWFE150 / EWFE350



FWFE50 / FWFE150 / FWFE350



EWFE75

EXTINGUISHER COVERS

Vinyl Fire Extinguisher Covers

Fire Extinguisher Covers are screened with black imprint and black trim. Available in English, French and Bilingual. English covers are stencilled "FIRE EXTINGUISHER KEEP CLEAR", French covers are stencilled "EXTINCTEUR D'INCENDIE", Bilingual covers are stencilled "EXTINCTEUR D'INCENDIE / FIRE EXTGR" (French over English). Made of reinforced vinyl with Velcro closures. Fluorescent red. Available with clear window or without.

PART#	DESCRIPTION	W	H	APPLICATION
BFEC10	10 lb. Extinguisher Cover, Bilingual, Window	12"	22"	All 10 lb Dry Chem Extgrs
BFEC10NW	10 lb. Extinguisher Cover, Bilingual, No Window	12"	22"	All 10 lb Dry Chem Extgrs
BFEC20	20 lb. Extinguisher Cover, Bilingual, Window	16"	25"	All 20 lb Dry Chem, 20 and 30 lb Cart Op Extgrs
BFEC20NW	20 lb. Extinguisher Cover, Bilingual, No Window	16"	25"	All 20 lb Dry Chem, 20 and 30 lb Cart Op Extgrs
BFEC30	30 lb. Extinguisher Cover, Bilingual, Window	16"	28"	All 30 lb Dry Chem Extgrs
BFEC30NW	30 lb. Extinguisher Cover, Bilingual, No Window	16"	28"	All 30 lb Dry Chem Extgrs
EFEC10	10 lb. Extinguisher Cover, English, Window	12"	22"	All 10 lb Dry Chem Extgrs
EFEC10NW	10 lb. Extinguisher Cover, English, No Window	12"	22"	All 10 lb Dry Chem Extgrs
EFEC20	20 lb. Extinguisher Cover, English, Window	16"	25"	All 20 lb Dry Chem, 20 and 30 lb Cart Op Extgrs
EFEC20NW	20 lb. Extinguisher Cover, English, No Window	16"	25"	All 20 lb Dry Chem, 20 and 30 lb Cart Op Extgrs
EFEC30	30 lb. Extinguisher Cover, English, Window	16"	28"	All 30 lb Dry Chem Extgrs
EFEC30NW	30 lb. Extinguisher Cover, English, No Window	16"	28"	All 30 lb Dry Chem Extgrs
FFEC10	10 lb. Extinguisher Cover, French, Window	12"	22"	All 10 lb Dry Chem Extgrs
FFEC10NW	10 lb. Extinguisher Cover, French, No Window	12"	22"	All 10 lb Dry Chem Extgrs
FFEC20	20 lb. Extinguisher Cover, French, Window	16"	25"	All 20 lb Dry Chem, 20 and 30 lb Cart Op Extgrs
FFEC20NW	20 lb. Extinguisher Cover, French, No Window	16"	25"	All 20 lb Dry Chem, 20 and 30 lb Cart Op Extgrs
FFEC30	30 lb. Extinguisher Cover, French, Window	16"	28"	All 30 lb Dry Chem Extgrs
FFEC30NW	30 lb. Extinguisher Cover, French, No Window	16"	28"	All 30 lb Dry Chem Extgrs

BFEC10 /
BFEC20 /
BFEC30BFEC10NW /
BFEC20NW /
BFEC30NWEFEC10 /
EFEC20 /
EFEC30EFEC10NW /
EFEC20NW /
EFEC30NWFFEC10 /
FFEC20 /
FFEC30FFEC10NW /
FFEC20NW /
FFEC30NW

EXTINGUISHER COVERS CONTINUED

Vinyl Elastic Back Fire Extinguisher Covers

Elastic Back Fire Extinguisher Covers with pull bottom strap for easy removal and bottom grommet to allow water to escape. These covers feature an elastic “shower cap” style back with bottom pull tab and water draining grommet. The elastic back allows you to stretch the cover over the extinguisher. The elastic band keeps the cover secure to the extinguisher and helps to prevent blowing off in wind. Available in English and French. English covers are stencilled “FIRE” and French are pictorial only for 2.5 and 5 lb. cover and stencilled “BOYAU D’INCENDIE” for the 10 and 20 lb. covers. Fluorescent red. Available with clear window or without.

PART#	DESCRIPTION	APPLICATION
EFEC2	2.5 lb. Elastic Back Extinguisher Cover, English, No Window	2.5 lb. Dry Chem Extgrs
EFEC5	5 lb. Elastic Back Extinguisher Cover, English, Window	5 lb. Dry Chem Extgrs
EFEC5NW	5 lb. Elastic Back Extinguisher Cover, English, No Window	5 lb. Dry Chem Extgrs
EFEC10EL	10 lb. Elastic Back Extinguisher Cover, English, Window	10 lb. Dry Chem Extgrs
EFEC10NWEL	10 lb. Elastic Back Extinguisher Cover, English, No Window	10 lb. Dry Chem Extgrs
EFEC20EL	20 lb. Elastic Back Extinguisher Cover, English, Window	20 lb. Dry Chem Extgrs
EFEC20NWEL	20 lb. Elastic Back Extinguisher cover, English, No Window	20 lb. Dry Chem Extgrs
FFEC2	2.5 lb. Elastic Back Extinguisher Cover, French, No Window	2.5 lb. Dry Chem Extgrs
FFEC5	5 lb. Elastic Back Extinguisher Cover, French, Window	5 lb. Dry Chem Extgrs
FFEC5NW	5 lb. Elastic Back Extinguisher Cover, French, No Window	5 lb. Dry Chem Extgrs
FFEC10EL	10 lb. Elastic Back Extinguisher Cover, French, Window	10 lb. Dry Chem Extgrs
FFEC10NWEL	10 lb. Elastic Back Extinguisher Cover, French, No Window	10 lb. Dry Chem Extgrs
FFEC20EL	20 lb. Elastic Back Extinguisher Cover, French, Window	20 lb. Dry Chem Extgrs
FFEC20NWEL	20 lb. Elastic Back Extinguisher cover, French, No Window	20 lb. Dry Chem Extgrs



HYDRANT COVERS

Vinyl Fire Hydrant Out of Service Covers

Fire Hydrant Out of Service Covers have reinforced grommets that allow for chain/wire to prevent removal. Available in English and French. English covers are stencilled “HYDRANT NOT IN SERVICE” and French covers are stencilled “BORNE D’INCENDIE HORS SERVICE”. Made of reinforced vinyl with Velcro enclosures. Fluorescent red.

PART#	DESCRIPTION	W	H
EHYDRANT	Fire Hydrant Cover, English	27	29¾
FHYDRANT	Fire Hydrant Cover, French	27	29¾



HEAVY DUTY COVERS

HD HOSE AND REEL COVERS

HD Hose Reel & Rack Covers

Heavy Duty Hose Reel covers are made of acrylic coated polyester. These covers have a much longer lifespan in harsh conditions. HD Hose Reel and Rack Reel covers are stencilled on both sides and come with Velcro fastener. Available in English and French. English covers are stencilled "FIRE HOSE KEEP CLEAR, FOR USE BY TRAINED PERSONS ONLY" and French covers are stencilled "BOYAU D'INCENDIE". Fluorescent Red.

PART#	DESCRIPTION	W	H	D	APPLICATION
EHDC25	Hose Reel cover for 24" High Capacity Reel, English	29"	24"	8¾"	HDR25HC
FHDC25	Hose Reel cover for 24" High Capacity Reel, French	29"	24"	8¾"	HDR25HC



EHDC25



FHDC25

HD FIRE EXTINGUISHER COVERS

HD Fire Extinguisher Covers

Heavy Duty Fire Extinguisher Covers made of Acrylic coated polyester with Velcro closures for superior weather protection and longevity in harsh conditions. Acrylic coating prevents water from permeating the cover. Red with black imprint and black trim. Not available with window. Available in English, French and Bilingual versions. English covers are stencilled "FIRE EXTINGUISHER KEEP CLEAR", French covers are stencilled "EXTINCTEUR D'INCENDIE", Bilingual covers are stencilled "EXTINCTEUR D'INCENDIE / FIRE EXTGR" (French over English). Fits portable, pressurized and cartridge operated extinguishers. Red with black imprint and black trim. Not available with window. 5 lb cover features and elastic "shower cap" style back instead of Velcro closure.

PART#	DESCRIPTION	W	H	APPLICATION
BHD10	10 lb. HD Extinguisher Cover, Bilingual	12"	22"	All 10 lb Dry Chem Extgrs
BHD20	20 lb. HD Extinguisher Cover, Bilingual	16"	25"	All 20 lb Dry Chem, 20 and 30 lb Cart Op Extgrs
BHD30	30 lb. HD Extinguisher Cover, Bilingual	16"	28"	All 30 lb Dry Chem Extgrs
EHD5	5 lb. HD Elastic Back Extinguisher Cover, English			5 lb. Dry Chem Extgrs
EHD10	10 lb. HD Extinguisher Cover, English	12"	22"	All 10 lb Dry Chem Extgrs
EHD20	20 lb. HD Extinguisher Cover, English	16"	25"	All 20 lb Dry Chem, 20 and 30 lb Cart Op Extgrs
EHD30	30 lb. HD Extinguisher Cover, English	16"	28"	All 30 lb Dry Chem Extgrs
FHD5	5 lb. HD Elastic Back Extinguisher Cover, Bilingual/French			5 lb. Dry Chem Extgrs
FHD10	10 lb. HD Extinguisher Cover, French	12"	22"	All 10 lb Dry Chem Extgrs
FHD20	20 lb. HD Extinguisher Cover, French	16"	25"	All 20 lb Dry Chem, 20 and 30 lb Cart Op Extgrs
FHD30	30 lb. HD Extinguisher Cover, French	16"	28"	All 30 lb Dry Chem Extgrs

BHD10 /
BHD20 /
BHD30

EHD5

EHD10 /
EHD20 /
EHD30

FHD5

FHD10 /
FHD20 /
FHD30

HD WHEELED UNIT COVERS

HD Wheeled Unit Covers

Heavy Duty covers for 50, 150 & 350 lb. wheeled units are made of Acrylic coated polyester and Velcro closures for superior weather protection and longevity in harsh conditions. Acrylic coating prevents water from permeating the cover. Red cover with black imprint and black trim. Durable equipment protection. Helps prevent tampering. Fast and easy to remove. Easy to spot location. Easy to clean. Available in English and French. English covers are stencilled "WHEELED FIRE EXTINGUISHER" and French covers are stencilled "EXTINCTEUR D'INCENDIE". Red. Now with straps at bottom corners to allow for bungee cord tie down.

PART#	DESCRIPTION	W	H	D	APPLICATION
EHD50	50 lb. HD Wheeled Unit Cover, English	23.5"	47.5"	16"	Fits 50 lb. Dry Chemical Wheeled
FHD50	50 lb. HD Wheeled Unit Cover, French	23.5"	47.5"	16"	Fits 50 lb. Dry Chemical Wheeled
EHD150	150 lb. HD Wheeled Unit Cover, English	42"	53"	30"	Fits 150 lb. Dry Chemical Wheeled
FHD150	150 lb. HD Wheeled Unit Cover, French	42"	53"	30"	Fits 150 lb. Dry Chemical Wheeled
EHD350	350 lb. HD Wheeled Unit Cover, English	52"	58"	38"	Fits 350 lb. Dry Chemical Wheeled
FHD350	350 lb. HD Wheeled Unit Cover, French	52"	58"	38"	Fits 350 lb. Dry Chemical Wheeled
E5075HD	50-75 lb. HD Wheeled Unit Cover, English	26"	54"	16"	50 & 75 lb CO2 Wheeled
F5075HD	50-75 lb. HD Wheeled Unit Cover, French	26"	54"	16"	50 & 75 lb CO2 Wheeled



HD HYDRANT COVERS

HD Fire Hydrant Out of Service Covers

Heavy Duty Hydrant Out of Service covers are made of acrylic coated polyester with Velcro closures. These covers have a much longer lifespan in harsh conditions. Red with reinforced grommets that allow for chain/wire to prevent removal. Available in English and French. English covers are stencilled "HYDRANT NOT IN SERVICE" and French covers are stencilled "BORNE D'INCENDIE HORS SERVICE".

PART#	DESCRIPTION	W	H
EHDHYDRANT	HD Fire Hydrant Cover, English	27"	29.75"
FHDHYDRANT	HD Fire Hydrant Cover, French	27"	29.75"



EXTINGUISHER CABINETS AND STANDS

MARK

Brooks Mark Series Extinguisher Cabinets and Accessories

Brooks' **MARK SERIES FIRE EXTINGUISHER CABINETS** better fit today's extinguisher sizes. Cabinets feature injection molded ABS plastic construction, so they are dent-, rust-, and corrosion-proof. Each cabinet comes with a brass lock, a plastic cover, and a screen-printed pictogram on the side. With no glass to break, there is no breaker bar to lose. Because they are light and nest easily together freight chargers are a fraction of what metal cabinets can cost.

Choose from three sizes: **Mark I Jr. Cabinets** for extinguishers with a maximum height of 16¾"; **Mark II Jr. Cabinets**, 20"; and **Mark II Cabinets**, 24".

Note: The Mark II will not hold a 20 lb. extinguisher.

PART#	DESCRIPTION	LOCATION	APPLICATIONS	W	H	D	MAX EXTGR H
MJM	Red Cabinet w/ Red Cover	Indoor/Outdoor	5 lb. Dry Chem	8½"	18¼"	5⅜"	16¾"
MJRC	Red Cabinet w/ Clear Cover	Indoor	5 lb. Dry Chem	8½"	18¼"	5⅜"	16¾"
MJWC	White Cabinet w/ Clear Cover	Indoor	5 lb. Dry Chem	8½"	18¼"	5⅜"	16¾"
MJWR	White Cabinet w/ Red Cover	Indoor	5 lb. Dry Chem	8½"	18¼"	5⅜"	16¾"
M2JM	Red Cabinet w/ Red Cover	Indoor/Outdoor	Tall 5 lb. & 10 lb. Dry Chem	9⅝"	21¾"	6⅜"	20"
M2JRC	Red Cabinet w/ Clear Cover	Indoor	Tall 5 lb. & 10 lb. Dry Chem	9⅝"	21¾"	6⅜"	20"
M2JWC	White Cabinet w/ Clear Cover	Indoor	Tall 5 lb. & 10 lb. Dry Chem	9⅝"	21¾"	6⅜"	20"
M2JWR	White Cabinet w/ Red Cover	Indoor	Tall 5 lb. & 10 lb. Dry Chem	9⅝"	21¾"	6⅜"	20"
M2M	Red Cabinet w/ Red Cover	Indoor/Outdoor	10-20 lb. Dry Chem	9⅝"	25¾"	6⅜"	24"
M2RC	Red Cabinet w/ Clear Cover	Indoor	10-20 lb. Dry Chem	9⅝"	25¾"	6⅜"	24"
M2WC	White Cabinet w/ Clear Cover	Indoor	10-20 lb. Dry Chem	9⅝"	25¾"	6⅜"	24"
M2WR	White Cabinet w/ Red Cover	Indoor	10-20 lb. Dry Chem	9⅝"	25¾"	6⅜"	24"
MJC	Clear Mark I Jr. Cover		MJ Cabinets	8⅞"	19¼"		
MJCR	Red Mark I Jr. Cover		MJ Cabinets	8⅞"	19¼"		
M1C	Clear Mark I Cover		M1 Cabinets	9"	20⅝"		
M1CR	Red Mark I Cover		M1 Cabinets	9"	20⅝"		
M2JC	Clear Mark II Jr. Cover		M2J Cabinets	10"	23"		
M2JCR	Red Mark II Jr. Cover		M2J Cabinets	10"	23"		
M2C	Clear Mark II Cover		M2 Cabinets	10"	27"		
M2CR	Red Mark II Cover		M2 Cabinets	10"	27"		



MJM /
M2JM /
M2M



MJRC /
M2JRC /
M2RC



MJWC /
M2JWC /
M2WC



MJWR /
M2JWR /
M2WR

WARRIOR

Cato Warrior Fire Extinguisher Cabinet and Accessories

WARRIOR FIRE EXTINGUISHER CABINETS, manufactured by Cato, Inc. with cabinet body injection molded of linear, high density red or white virgin high-impact polystyrene of .110 wall thickness with ultra-violet inhibitors and high-impact crystal polystyrene .100 wall thickness one-piece cover. The design allows for natural ventilation and pitched drainage. The construction of the cabinets means they are rust and dent proof and cheaper to ship than metal cabinets. Each cabinet features a locking seal, two-piece construction and no breaker bar to replace.

PART#	DESCRIPTION	APPLICATIONS
955RCC	Red Cabinet w/ Clear Cover	5 lb. Dry Chem
955RCR	Red Cabinet w/ Red Cover	5 lb. Dry Chem
955WCC	White Cabinet w/ Clear Cover	5 lb. Dry Chem
955WCR	White Cabinet w/ Red Cover	5 lb. Dry Chem
9510RCC	Red Cabinet w/ Clear Cover	10 lb. Dry Chem
9510RCR	Red Cabinet w/ Red Cover	10 lb. Dry Chem
9510WCC	White Cabinet w/ Clear Cover	10 lb. Dry Chem
9510WCR	White Cabinet w/ Red Cover	10 lb. Dry Chem
955065R	955 Cover, Red	955 Series
955045C	955 Cover, Clear	955 Series
9510610R	9510 Cover, Red	9510 Series
9510410C	9510 Cover, Clear	9510 Series



955RCC / 9510RCC



955RCR / 9510RCR



955WCC / 9510WCC



955WCR / 9510WCR

PART#	INSIDE DIMS			OUTSIDE DIMS			MAX EXTR
	W	H	D	W	H	D	H
955 Cabinet	6½"	17"	6½"	8"	19"	6½"	17"
9510 Cabinet	7"	21"	7"	9"	23¾"	7⅞"	21"
955 Cover				8¾"	20¾"		
9510 Cover				9¾"	24¾"		

OEC

Heavy Duty Outdoor Series Fire Extinguisher Cabinet

OEC SERIES surface mount cabinets are designed with tough winters and environments in mind. These cabinets feature a sloped Roof for water run-off, Red Polyester Powder Coat Finish, Full length stainless steel piano hinge, Fully-gasketed door and Full metal door with zinc plated keyed paddle latch (2 keys, #151 keyed alike included).

PART#	DESCRIPTION	APPLICATIONS
OEC10	10 lb. Extgr HD Outdoor Steel Cabinet, Red	10 lb. Dry Chem, 10 lb. Cart Op Extgrs
OEC20	20 lb. Extgr HD Outdoor Steel Cabinet, Red	20 lb. Dry Chem, 20 & 30 lb. Cart Op Extgrs
OEC30	30 lb. Extgr HD Outdoor Steel Cabinet, Red	30 lb. Dry Chem, 20 & 30 lb. Cart Op Extgrs

PART#	CABINET MIN INSIDE DIMENSIONS			CABINET MAX OUTSIDE DIMENSIONS			MAX EXTGR H	SHIP WGT. Lbs
	W	H	D	W	H	D		
OEC10	11¾"	24"	7¾"	12¼"	24¾"	8½"	23½"	30
OEC20	13¾"	27¾"	8¾"	14"	28"	9"	27¼"	35
OEC30	13¾"	31¾"	8¾"	14¼"	33"	9¼"	31¼"	40



OEC10 / OEC20 / OEC30

FGC-CAT

FireTech™ Fiberglass Cabinets

A major step up in fire extinguisher storage and protection, **FireTech™ FIBERGLASS CABINETS** are designed to ward off salt air, chemicals, moisture, dust, insects, temperature extremes, and other harmful elements. These durably constructed cabinets feature a door-sealing method that shuts out most anything and an easy-view window and corrosion-resistant handle for extra convenience. All cabinets come standard with a full-length stainless steel hinge, rivets, and latches for added peace of mind. Comes in UV-resistant high visibility red.

PART#	DESCRIPTION	APPLICATIONS	W	H	D	MAX EXTGR H
FGC10	Fiberglass Extgr Cabinet fits 5 & 10 lb Dry Chem	5 & 10 lb Dry Chem, 20 lb Cart Op	13"	26 $\frac{1}{8}$ "	9"	23 $\frac{1}{2}$ "
FGC26	Fiberglass Extgr Cabinet fits 20 lb Dry Chem	20 lb Dry Chem, 30 lb Cart Op	15 $\frac{1}{2}$ "	27 $\frac{1}{8}$ "	9 $\frac{3}{4}$ "	24 $\frac{1}{2}$ "
FGC35R	Fiberglass Extgr Cabinet fits 30 lb Dry Chem	30 lb Dry Chem	19 $\frac{3}{8}$ "	36 $\frac{1}{4}$ "	13 $\frac{1}{2}$ "	33 $\frac{1}{4}$ "
FGCLATCH	Latch for FGC Model Cabinets					



FGC26



FGC35R

The **FireTech™ FIBERGLASS STAND** is designed for use with FGC26 Fiberglass Cabinet. Its red finish perfectly matches the cabinet and the base comes with four pre-drilled holes for permanent attachment to docks or other locations. There are also mounting holes and hardware for attaching the cabinet to the stand. Sand can be added as well, for temporary placement. Measures 27 $\frac{1}{2}$ " tall with a 15 $\frac{1}{2}$ " x 15 $\frac{1}{2}$ " base and 8 $\frac{1}{4}$ " x 11 $\frac{3}{4}$ " top surface. **NOTE: Sand, FGS26 cabinet and mounting hardware not included.**

PART#	DESCRIPTION	APPLICATION	W	H	D
FES2	Fiberglass Cabinet Stand Only	For FGC26 cabinet	15 $\frac{1}{2}$ "	27 $\frac{1}{2}$ "	15 $\frac{1}{2}$ "



FES2

FT101

FireTech ABS Cabinets

The **FireTech™ ABS EXTINGUISHER CABINET** protects an extinguishers or life safety equipment from the harshest of environments. Ideal for both extinguisher, fire blankets and safety equipment use. The clear door allows easy inspection, while the door-swing preference (left or right) and gasket provides long-term weather protection. A quick-release catch ensures rapid access to what is inside too.

- Clear polycarbonate front with red ABS back
- Accommodates stored pressure dry chemical and clean agent extinguishers, up to 20 lb
- Door seal designed for long-term weather protection

PART#	Cabinet Min Inside Dimensions			Cabinet Max Outside Dimensions			MAX EXTGR	SHIP WGT. Lbs
	W	H	D	W	H	D		
FT101	8"	25 $\frac{1}{2}$ "	8"	10 $\frac{7}{8}$ "	29 $\frac{7}{8}$ "	8 $\frac{1}{2}$ "	Up to 20 lb. Stored Pressure Extgr	8.85



FT101

CHIEF

Cato Chief Fire Extinguisher Cabinet and Accessories

Cato **CHIEF FIRE EXTINGUISHER CABINETS** feature body and frame injection molded of red or white virgin high-impact crystal polystyrene of .110 wall thickness, chromium plated brass cylinder lock, and key with weather-proof protective lock cover and polypropylene plastic injected molded hammer with brass impact surface, flexible torsion, ribbed grip surface and clear nylon-jacketed type 304 stainless steel mechanical cable. Available in red or white. All cabinets come with a clear cover case, UV-resistant panel, break hammer, frame and lock.

PART#	DESCRIPTION
1055RRCH	5 lb. Red Chief Cabinet
1055WWCH	5 lb. White Chief Cabinet
10510RRCH	10 lb. Red Chief Cabinet
10510WWCH	10 lb. White Chief Cabinet
10520RRCH	20 lb. Red Chief Cabinet
10520WWCH	20 lb. White Chief Cabinet

PART#	DESCRIPTION	W	H
10575	1055 Clear Panel, 5lb	7 ⁵ / ₈ "	18 ⁵ / ₈ "
11075	10510 Clear Panel, 10lb	8 ⁵ / ₈ "	22 ⁵ / ₈ "
12075	10520 Clear Panel, 20lb	10 ⁵ / ₈ "	27 ³ / ₄ "



1055RRCH /
10510RRCH /
10520RRCH



10515WWCH /
10510WWCH /
10520WWCH

MODEL	APPLICATIONS	Cabinet Min Inside Dimensions			Cabinet Max Outside Dimensions			MAX EXTGR	SHIP WGT. Lbs
		W	H	D	W	H	D		
1055	5 lb. Dry Chem	6"	16 ³ / ₄ "	5 ³ / ₈ "	8"	19"	6 ³ / ₈ "	16 ¹ / ₂ "	3.42
10510	10 lb. Dry Chem	6 ³ / ₄ "	20 ¹ / ₂ "	6"	9"	23"	7"	20 ¹ / ₄ "	4.4
10520	20 lb. Dry Chem, Pressure Water	9"	26"	8"	11"	28"	9"	25 ³ / ₄ "	5.84

STANDS

FireTech™ Portable Extinguisher Cabinet & Stands

These cabinet and stand kits solve the problem of locating fire extinguishers on jobsites, project areas, and in remote locations. Constructed from rust/fade-proof materials, that meet OSHA requirements, these cabinet/stand combos come with handles for convenient carry. In addition, they come with scored break-fronts and cylinder locks. Other features include a heavy-duty rubber stand base, informational decals, and stackable storage/transport. White/Red. **NOTE: Extinguisher sold separately.**

PART#	DESCRIPTION	W	H	D
FGSWC10	Portable Cabinet & Stand (Only), 10 lb.	20"	43"	20"
FGSWC20	Portable Cabinet & Stand (Only), 20 lb.	20"	43"	20"

FGSWC10 /
FGSWC20



The **Original Firemate** is a stackable, **PORTABLE FIRE EXTINGUISHER STAND** that is made of tough HDPE plastic. The stand holds 5, 10, or 20 lb extinguishers and its wide base resists tipping. Meets OSHA requirements. 8"H x 7¹/₄"W x 7¹/₄"D recess for extinguisher.

NOTE: Extinguisher sold separately.

PART#	DESCRIPTION	W	H	D
FMRGC	Portable Extinguisher Stand (Only)	21"	34"	21"



FMRGC

STANDS CONTINUED

Make moving from jobsite to jobsite easy with this portable **ECONOMY FIRE EXTINGUISHER STAND**. It holds a 5, 10, or 20 lb dry chemical extinguisher and is ideal for wherever a fire extinguisher is required but cannot be permanently mounted. Its 16" x 16" base features a molded-in handle for ease of movement and a large 2½" fill hole for the addition of sand (up to 35 lb) to weight the base. The heavy-duty upright attaches easily to base without the use of tools. Constructed from red powder coated steel and predrilled for a fire extinguisher wall hook. For use on construction sites, exhibit halls, workshops, fairs and more. **NOTE: Extinguisher, sand and wall hook are not included.**

PART#	DESCRIPTION	W	H	D
FES1	Economy Fire Extinguisher Stand	16"	48"	16"



FES1

The stackable **FireTech™ FES3 PORTABLE FIRE EXTINGUISHER STAND** accommodates larger extinguishers. Its 8" x 8" Diameter recessed cup holds 5 lb–30 lb and 2.5 gal water stored pressure extinguishers. Made of UV-stabilized HDPE plastic, it is ideal for indoor/outdoor use. Plus its 20½" x 20½" base offers superior stabilization. Meets OSHA construction and temporary extinguisher location requirements too. 32"H x 20½"W x 20½"D. Red. **NOTE: Includes two BL135W cabinet signs (for optional use).**

PART#	DESCRIPTION	W	H	D
FES3	Extinguisher Stand	20½"	32"	20½"



FES3

CLASSIC

Classic Series Metal Extinguisher Cabinets

CLASSIC SERIES metal extinguisher cabinets come complete with cylinder lock keyed alike, acrylic plastic scored viewing panel, break glass hammer and chain and break glass sticker. Cabinets are made of 20-gauge galvanized steel tub. 18-gauge lock front and a baked white enamel finish. Plastic fronts are grid scored for easy breakage.

PART#	DESCRIPTION
C100	Classic Cabinet, Small, for 5lb Dry Chem
C999	Classic Cabinet, Medium, for 10lb Dry Chem
C104	Classic Cabinet, Large, for 20lb Dry Chem, 10 lb CO2, PW
PF99	Plastic Front for discontinued C99 Cabinet
PF99T	Plastic Front for discontinued C99T Tall Cabinet
PF100	Plastic Front for Classic 100 Cabinet
PF999	Plastic Front for Classic 999 Cabinet
PF104	Plastic Front for Classic 104 Cabinet



C100 / C999



C104



Plastic Fronts

ATTRIBUTE	SPECIFICATION		
Model No.	C100	C999	C104
Applications	5 lb Dry Chem	10 lb Dry Chem	20 lb Dry Chem, 10 lb CO2, 2.5 Gal Pressure Water
Width	8½"	10½"	14⅞"
Height	20½"	24¼"	30⅞"
Depth	6"	6½"	9"
Door & Tub	20 GA. Tub, 18 GA. Lock Front Galvanized Steel Construction		
Finish	Electrostatically Applied Baked White Enamel Paint		
Label	UV Resistant Decal		
Includes	Keyed Alike Cylinder Lock with Key		

ARCHITECTURAL

Elite Architectural Fire Extinguisher Cabinets

Durable, attractive & precision built **Elite Series Cabinets** are an ideal choice for virtually any architectural specification. A wide variety of standard and custom sizes, as well as finishes, makes these cabinets the industry standard. All cabinets are available from stock in an extensive selection of sizes for recessed or semi-recessed wall mountings. Surface mount cabinets are available as well. Standard units provided with full-length semi-concealed piano hinges, flush stainless steel door paddle latches, full viewing panel and completely finished with a baked grey enamel paint finish.

Other models available include full metal door and/or #304 stainless steel finish for recessed, semi-recessed and surface mount cabinets. Options include lockable fronts and white finish. Other colour options available, call for details.

NOTE: Acrylic Front Glass Sold Separately, BUBBLE Front Included with BC1430.

The **ELITE Series of Extinguisher Cabinets** accommodate from 5 lb to 20 lb Dry Chemical, 10 lb CO2 and 2½ Gallon Pressure Water Extinguishers.

PART#	DESCRIPTION
5SR	5 lb. Semi-Recessed Extinguisher Cabinet Only
5SRSS	5 lb. Semi-Recessed Extinguisher Cabinet, Stainless Steel
5FR	5 lb. Fully Recessed Extinguisher Cabinet Only
A413	4" x 13" Acrylic Front for 5 lb Cabinet Viewing Panel
10SR	10 lb. Semi-Recessed Extinguisher Cabinet Only
10SRSS	10 lb. Semi-Recessed Extinguisher Cabinet, Stainless Steel
10SRW	10 lb. Semi-Recessed Extinguisher Cabinet Only, White
10FR	10 lb. Fully Recessed Extinguisher Cabinet Only
A520	5" x 20" Acrylic Front for 10 lb Cabinet Viewing Panel
BC1430	20 lb. Semi-Recessed Extinguisher Cabinet incl. Bubble
BC1430W	20 lb. Semi-Recessed Extinguisher Cabinet incl. Bubble, White



ATTRIBUTE	SPECIFICATION				
Model No.	5SR	5FR	10SR	10FR	BC1430
Extgr Max	5 lb Dry Chem		10 lb Dry Chem		20 lb Dry Chem or 10 lb CO2
Style	Semi-Recessed	Recessed	Semi-Recessed	Recessed	Semi-Recessed
Tub Width	8"	8"	9"	9"	14½"
Tub Height	17"	17"	24"	24"	30"
Tub Depth	5"	5"	6"	6"	8"
Frame Turnback	1"	¼"	2"	¼"	1"
Wall Depth	4"	5"	4"	6"	4"
Front Type	Full Glass		Full Glass		Bubble Canopy
Front Glass	A413 (Sold Separately)		A520 (Sold Separately)		BUBBLE (included)
Door & Trim	16 ga. Door & Trim (1.5 mm)		16 ga. Door & Trim (1.5 mm)		14 ga. Door & Trim
Tub	22 ga. Tub (.75 mm)		22 ga. Tub (.75 mm)		22 ga. Tub (.75 mm)
Finish	Grey baked enamel finish				
Construction	Welded tub and front trim				
Door Lock	Flush SS Paddle Latch				
Includes	Glass clips included				
Ship Weight (lbs)	9.1	9.1	15.5	15	32

ARCHITECTURAL CONTINUED

Elite Architectural Hose and Extinguisher Cabinets

Durable, attractive & precision built **Elite Architectural Hose and Extinguisher Cabinets** are an ideal choice for virtually any architectural specification. A wide variety of standard & custom sizes, as well as finishes, makes this cabinet the industry standard. All cabinets are available from stock for recessed or surface wall mountings.

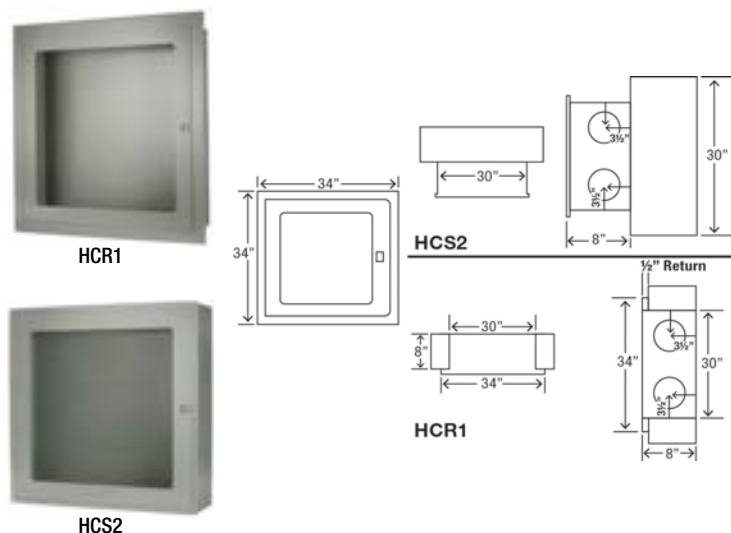
Standard units provided with full-length semi-concealed piano hinges, flush stainless steel door paddle latches, full viewing panel and completely finished with a baked grey enamel paint finish.

Other models available include full metal door and/or #304 stainless steel finish for recessed and surface mount cabinets. Options include lockable fronts and white finish. Other colour options available, call for details.

NOTE: Acrylic Front Glass Sold Separately

The **ELITE Series of 30 x 30 x 8 Recessed and Surface Mount Hose and Extinguisher Cabinets** accommodate 1½” to 2½” valve plus 50, 75 or 100 foot hose. Cabinets also accommodate up to a 20 lb. dry chemical or a pressure water extinguisher.

PART#	DESCRIPTION
HCR1	Recessed Hose & Extgr Cabinet Only
HCS2	Surface Mount Hose & Extgr Cabinet Only
A2626	Acrylic Front for Recessed Hose & Extgr Cabinet Viewing Panel
A2424	Acrylic Front for Surface Mount Hose & Extgr Cabinet Viewing Panel



ATTRIBUTE	SPECIFICATION	
Model No.	HCR1	HCS2
Style	Recessed	Surface Mount
Extgr Max	Up to 20 lb Dry Chem or PW	
Valves	1½”, 2½”	
Tub Width	30”	
Tub Height	30”	
Tub Depth	8”	
Frame Turnback	½”	n/a
Wall Depth	8”	n/a
Front Type	Full Glass	
Front Glass	A2626 (Sold Separately)	A2424 (Sold Separately)
Door & Trim	14 ga. Door & Trim	
Tub	18 ga. Tub	
Finish	Grey baked enamel finish	
Door Lock	Flush SS Paddle Latch	
Includes	Glass clips included	
Other	Removable Frame for left or right door swing	
Ship Weight (lbs)	41	41

Plastic Semi-Recessed Extinguisher Cabinet

Fire Extinguisher Cabinet with body, bezel and door, injection molded of white virgin 2 Izod Co-Polymer Polypropylene of .15 wall thickness, virgin acrylic Plaskolite panel of .080 thickness, stainless steel hinge, chromium-plated door handle and roller catch. Locking cabinet model is available. White Only. Fits 5 lb and most 10 lb extinguishers (check inside dims to verify).

PART#	DESCRIPTION
41001	5-10 lb. Semi-Recessed Cabinet, White
41001L	5-10 lb. Semi-Recessed Cabinet, White w/ Lock



ATTRIBUTE	SPECIFICATION
Model No.	41001 / 41001L
Style	Semi-Recessed
Extgr Max	Most 10 lb Dry Chem
Tub Width	8½”
Tub Height	23¼”
Tub Depth	5⅝”
Frame Turnback	2⅞”
Rough Opening H	25”
Rough Opening W	10½”
Wall Depth	4”
Outside Trim H	27⅝”
Outside Trim W	13⅜”
Front Type	Full Glass
Finish	White
Ship Weight (lbs)	10

We are in the business of growing your business

ACCESS DOORS

WB-UAD Utility Access Door

Durable, precision built **UTILITY ACCESS DOORS** are available in a variety of standard sizes from 6" X 6" up to 24" x 24", and have different finish options.

Door and Trim: 16 ga. steel. Trim being 1½" wide.

Return Frame: 16 ga. steel having a depth of 1¼".

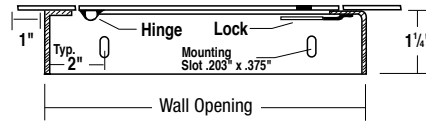
Hinge: One piece hidden pivot rod hinge.

Latches: Flush, stainless steel cam operated with screwdriver. Latches are positioned opposite hinge as well as top and bottom on larger sizes.

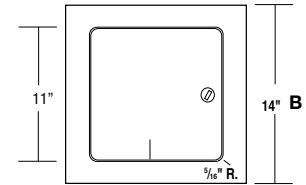
Finish: Electrostatically applied baked grey enamel coat over rust-inhibiting phosphate treated steel. This coating can be used as a finish or as a prime coating.

Optional Available: (AT EXTRA COST)

- Keyed Cylinder Lock with 2 keys
- Stainless Steel #304



SECTION DETAIL



ELEVATION



WB-UAD

PART#	A/B DOOR SIZE	WALL OPENING	HINGES	CAM LATCH	SHIP WGT (LBS.)
WB-UAD-88	8" X 8"	8½" X 8½"	1	1	2.5
WB-UAD-1010	10" X 10"	10½" X 10½"	1	1	4
WB-UAD-1212	12" X 12"	12½" X 12½"	1	1	5
WB-UAD-1616	16" X 16"	16½" X 16½"	1	3	7.5
WB-UAD-1818	18" X 18"	18½" X 18½"	1	3	9
WB-UAD-2424	24" X 24"	24½" X 24½"	1	4	15

Other sizes available upon request.

WB-DW Metal Access Door for Drywall Surfaces

Durable, precision built **METAL ACCESS DOORS FOR DRYWALL SURFACES** are available in a variety of standard sizes from 8" x 8" up to 36" x 36", and have different finish options.

Door: 14 ga. steel.

Box Return Frame: 16 ga. steel. These models have a 1" wide perforated flange of 24 ga. galvanized steel for mounting purposes.

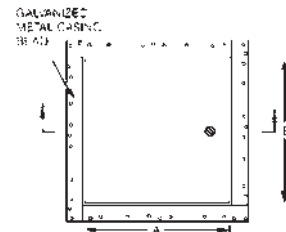
Hinge: Fully-concealed piano type hinge. Number of hinges varies with size of door and will be placed on long side of door unless otherwise requested.

Latches: Flush, stainless steel cam operated with screwdriver. Latches are positioned opposite hinge as well as top and bottom on larger sizes.

Finish: Electrostatically applied baked grey enamel coat over rust inhibiting phosphate treated steel. This coating can be used as a finish or as a prime coating.

Options Available: (AT EXTRA COST)

- Keyed Cylinder Locks with 2 keys
- Air-tight Neoprene Gasketing
- Stainless Steel Finish #304 or #316
- Additional Accessories refer to back cover



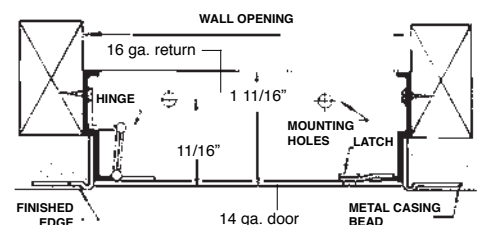
ELEVATION



WB-DW

PART#	A/B DOOR SIZE	WALL OPENING	HINGES	CAM LATCH	SHIP WGT (LBS.)
WB-DW-1010	10" X 10"	10¼" X 10¼"	1	1	5
WB-DW-1212	12" X 12"	12¼" X 12¼"	1	1	7
WB-DW-1224	12" X 24"	12¼" X 24¼"	3	2	12
WB-DW-1414	14" X 14"	14¼" X 14¼"	2	3	9
WB-DW-1616	16" X 16"	16¼" X 16¼"	2	3	11
WB-DW-1818	18" X 18"	18¼" X 18¼"	2	3	12
WB-DW-2222	22" X 22"	22¼" X 22¼"	3	4	18
WB-DW-2230	22" X 30"	22¼" X 30¼"	4	4	24
WB-DW-2424	22" X 36"	22¼" X 36¼"	5	5	27

Other sizes available upon request.



SECTION DETAIL

WB-FR Standard Fire-Rated Access Door

Durable, precision built **STANDARD FIRE-RATED ACCESS DOORS** are available in a variety of standard sizes from 8" x 8" up to 48" x 48", and have different finish options. 24" x 48" size and larger is intended for vertical (wall) application only.

Underwriter Laboratories 1½ hour "B" label 250 F maximum temperature rise in 30 minutes, for vertical wall installations. UL File #R10364 .



Warnock Hersey International; 1 Hr. rating for combustible floor/ceiling assembly. Report # WHI-495-PSH-0191.

Warnock Hersey International; 3 Hr. rating for non-combustible floor/ceiling assembly, Report # WHI-495-PSH- 0192.

This door may be used in a 2 hr. fire- rated wall assembly.

Door: 18 ga. steel.

Return Frame and Trim: 16 ga. steel.

Insulation: 1⅞" thick mineral wool contained within door cavity.

Hinge: Fully concealed, pivot type hinge. Allows opening to 170°.

Latches: Self-latching direct action latch, opposite hinge. The latch will accept both key and knurled knob, which will be included with each door.

Automatic Panel Closer: Furnished on all doors.

Inside Panel Release: Furnished on all doors.

Finish: Electrostatically applied baked grey enamel, over rust-inhibiting phosphate treated steel. This coating can be used as a finish or as a prime coat.

Optional Finish:

- Stainless Steel Type 304 or 316

Options: (AT EXTRA COST)

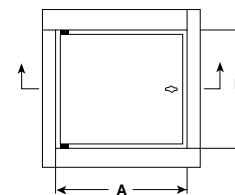
- Mortise Cylinder Prep
- Pemko Hot Smoke Seal Gasketing

Ceiling Installation: To comply with current fire regulations, largest size acceptable is 24" x 36".

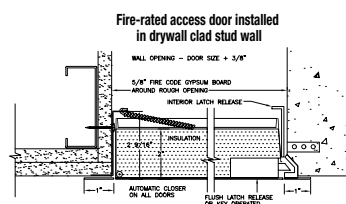
PART#	A/B DOOR SIZE	WALL OPENING	HINGES	SLAM CATCH	SHIP WGT (LBS.)
WB-FR-88	8" X 8"	8¼" X 8¼"	1	1	7
WB-FR-1010	10" X 10"	10¼" X 10¼"	1	1	10
WB-FR-1212	12" X 12"	12¼" X 12¼"	1	1	12
WB-FR-1218	12" X 18"	12¼" X 18¼"	1	1	19
WB-FR-1224	12" X 24"	12¼" X 24¼"	1	1	18
WB-FR-1414	14" X 14"	14¼" X 14¼"	1	1	15
WB-FR-1616	16" X 16"	16¼" X 16¼"	1	1	18
WB-FR-1818	18" X 18"	18¼" X 18¼"	1	1	21
WB-FR-1824	18" X 24"	18¼" X 24¼"	1	1	26
WB-FR-2020	20" X 20"	20¼" X 20¼"	1	1	26
WB-FR-2030	20" X 30"	20¼" X 30¼"	1	2	38
WB-FR-2136	21" X 36"	21¼" X 36¼"	1	1	43
WB-FR-2222	22" X 22"	22¼" X 22¼"	1	1	29
WB-FR-2224	22" X 24"	22¼" X 24¼"	1	1	30
WB-FR-2230	22" X 30"	22¼" X 30¼"	1	2	37
WB-FR-2236	22" X 36"	22¼" X 36¼"	1	2	44
WB-FR-2424	24" X 24"	24¼" X 24¼"	1	1	32
WB-FR-2430	24" X 30"	24¼" X 30¼"	1	2	40
WB-FR-2436	24" X 36"	24¼" X 36¼"	1	2	46
WB-FR-2448	24" X 48"	24¼" X 48¼"	1	2	62
WB-FR-3030	30" X 30"	30¼" X 30¼"	1	2	50
WB-FR-3232	32" X 32"	32¼" X 32¼"	1	2	54
WB-FR-3636	36" X 36"	36¼" X 36¼"	1	2	67
WB-FR-3648	36" X 48"	36¼" X 48¼"	1	2	83
WB-FR-4848	48" X 48"	48¼" X 48¼"	1	2	104



WB-FR-88



ELEVATION



SECTION DETAIL



Fire-rated access door installed in three hour ceiling system

On size 16" x 16" and larger, extra spring supplied with door must be attached from back of door pan to framing or floor above in such a manner to insure that door is self-closing

CABINET ALARMS, FRONTS, LOCKS AND LABELS

MARK

PART#	DESCRIPTION	W	H
MJC	Clear Mark I Jr. Cover	8 ⁷ / ₈ "	19 ¹ / ₄ "
MJCR	Red Mark I Jr. Cover	8 ⁷ / ₈ "	19 ¹ / ₄ "
M1C	Clear Mark I Cover	9"	20 ⁵ / ₈ "
M1CR	Red Mark I Cover	9"	20 ⁵ / ₈ "
M2JC	Clear Mark II Jr. Cover	10"	23"
M2JCR	Red Mark II Jr. Cover	10"	23"
M2C	Clear Mark II Cover	10"	27"
M2CR	Red Mark II Cover	10"	27"
BLM12	"Pull Here" For Fire Extinguisher Cabinet Covers Label	4"	2 ¹ / ₂ "
FBLM12	French "Pull Here" For Fire Extinguisher Cabinet Covers Label	4"	2 ¹ / ₂ "



MARK COVERS

WARRIOR

PART#	DESCRIPTION	W	H
955065R	955 Cover, Red	8 ³ / ₈ "	20 ³ / ₈ "
955045C	955 Cover, Clear	8 ³ / ₈ "	20 ³ / ₈ "
9510610R	9510 Cover, Red	9 ³ / ₈ "	24 ³ / ₈ "
9510410C	9510 Cover, Clear	9 ³ / ₈ "	24 ³ / ₈ "



955065R / 9510410R

CHIEF

PART#	DESCRIPTION	W	H
10011R	Red Hammer Assembly		
10011W	White Hammer Assembly		
10505	1055 White Frame w/Lock, 5lb	8 ⁵ / ₁₆ "	19 ⁵ / ₁₆ "
10555	1055 Red Frame w/Lock, 5lb	8 ⁵ / ₁₆ "	19 ⁵ / ₁₆ "
11005	10510 White Frame w/Lock, 10lb	9 ³ / ₈ "	23 ³ / ₈ "
11055	10510 Red Frame w/Lock, 10lb	9 ³ / ₈ "	23 ³ / ₈ "
12005	10520 White Frame w/Lock, 20lb	11 ³ / ₈ "	28 ³ / ₈ "
12055	10520 Red Frame w/Lock, 20lb	11 ³ / ₈ "	28 ³ / ₈ "
10575*	1055 Clear Scored Panel, 5lb	7 ⁵ / ₈ "	18 ⁵ / ₈ "
11075*	10510 Clear Scored Panel, 10lb	8 ⁵ / ₈ "	22 ⁵ / ₈ "
12075*	10520 Clear Scored Panel, 20lb	10 ⁵ / ₈ "	27 ³ / ₄ "

*New style. "Missing" upper right corner, makes it simpler to slip fingers behind and pull out panel for extinguisher service.



10505 / 11005 / 12005 10555 / 11055 / 12055 10575 11075 12075

CATO CUSTOMIZER PANELS

Always have a replacement front for an extinguisher cabinet on hand that will fit whatever you may find in the field. Save time and money by being able to replace on site without the need for expensive custom made fronts and the time it takes to make and get them. These safe, long-lasting, UV-resistant acrylic panels will fit most CATO Chief cabinets, but, if needed, can be trimmed to fit most other cabinets as well.

1. Measure the size of the cabinet break glass window slot.
2. Carefully remove the blue film backing. Place panel carefully on a flat, clean surface and mark the scores to be trimmed.
3. Run a box cutter or similar tool lightly along the score you want to trim. Do this two to three times.
4. Place a pair of needle nose pliers or your hands on the outside edge of the score you want to trim and break off the unneeded portion.

PART#	DESCRIPTION	W	H	BREAKS TO MIN W x H
10575C	105-5 Customizer Panel	7 ⁵ / ₈ "	18 ¹ / ₄ "	4 ⁵ / ₁₆ " x 9 ⁵ / ₁₆ "
11075C	105-10 Customizer Panel	8 ⁵ / ₈ "	22 ⁵ / ₈ "	5 ¹ / ₂ " x 11 ¹ / ₄ "
12075C	105-20 Customizer Panel	10 ⁵ / ₈ "	27 ³ / ₄ "	5 ¹ / ₂ " x 17 ⁵ / ₈ "



CLASSIC

Acrylic Break Front

Grid pattern scored acrylic viewing panel. Grid pattern increases chances of breakage over "X" scored fronts. The greatest diameter of the extinguisher is in the middle of the cabinet where the lines of the "X" intersect. Individuals tend to strike the panel here. If the extinguisher rests against the panel it may be harder or take longer to break. The grid pattern removes this visual cue so that the extinguisher can be potentially accessed faster.

PART#	DESCRIPTION	W	H
PF99	Plastic Front for discontinued C99 Cabinet	7 ³ / ₄ "	15"
PF99T	Plastic Front for discontinued C99T Tall Cabinet	8"	19 ³ / ₄ "
PF100	Plastic Front for Classic 100 Cabinet	8 ¹ / ₄ "	18"
PF999	Plastic Front for Classic 999 Cabinet	10 ¹ / ₄ "	21 ³ / ₄ "
PF104	Plastic Front for Classic 104 Cabinet	13 ¹ / ₁₆ "	27 ⁵ / ₈ "



Plastic Fronts

Lock Front

Lock Front w/Cylinder Lock for Classic Cabinets comes complete with universal camlock and #151 keys. 18 GA. Galvanized Steel Construction.

PART#	DESCRIPTION
LFC99	Lock Front w/Cylinder Lock for discontinued C99 Cabinet
LFC99T	Lock Front w/Cylinder Lock for discontinued C99T Cabinet
LFC100	Lock Front w/Cylinder Lock for Classic 100 Cabinet
LFC999	Lock Front w/Cylinder Lock for Classic 999 Cabinet
LFC104	Lock Front w/Cylinder Lock for Classic 104 Cabinet
CL	Replacement Universal Cam Lock w/#151 Keys (2)
CLKEY	Replacement #151 Keys for Cam Lock



Lock Fronts

CL

Breaker Bar

PART#	DESCRIPTION
BGH	Cabinet Breaker Bar w/chain
BGH6	Break Glass Hammer w/chain



BGH

BGH6

ELITE

PART#	DESCRIPTION	APPLICATION	W	H
A413	Acrylic Front for 5- Cabinet Viewing Panel	5SR, 5FR	4"	13"
A520	Acrylic Front for 10- Cabinet Viewing Panel	10SR, 10FR	5"	20"
BUBBLE	Acrylic Front for Bubble Canopy Cabinet Viewing Panel	BC1430	10¾"	27"
A2626	Acrylic Front for Recessed Hose & Extgr Viewing Panel	HCR1	26"	26"
A2424	Acrylic Front for Surface Mount Hose & Extgr Viewing Panel	HCS2	24"	24"
BL253	Fire Extinguisher Cabinet and Bubble Front Decal	BC1430	2"	19"
BL254	Fire Extinguisher Cabinet Decal	BC1430	9"	2¾"
PL	Recessed Cabinet Paddle Latch, Stainless Steel (small)	All		
CORBIN	Corbin Latch (Old Style)	Old Style		
GLASSCLIPS	Package of 8 replacement clips to hold glass/acrylic fronts	All		



LOCKS

LAMINATED PADLOCK, from **Master Lock®**, features a four-pin cylinder nickel-plated steel body and hardened steel shackle. Shackle is ¼" thick with an inside measure 7/8" x 13/16". All locks are keyed differently. Ideal for group lock box and high-security applications.

PART#	DESCRIPTION
L40	Laminated Padlock, 7/8" Shackle



Corrosion-resistant **BASIC PADLOCK** features an all brass shackle, making it ideal for cabinets and other security requirements where economy and keyed-alike convenience is essential. 5/8" Shackle.

PART#	DESCRIPTION
M12L	Brass Padlock Keyed Alike, 5/8" Shackle



MASTER LOCK® is a name synonymous with top-quality padlocks. The keyed-alike **BREAKAWAY STEEL PADLOCK** has a 1¾"-wide laminated steel body for superior strength and comes with two keys, a steel shackle for strong cut resistance, and a warded locking mechanism that helps minimize jamming from foreign matter, like dirt and grime. And it's rustproof for extended wear.

PART#	DESCRIPTION
ML500KA	Keyed-Alike Breakaway Steel Padlock, 13/16" Shackle



BREAKAWAY BRASS PADLOCK is for securing cabinets and other equipment until needed in an emergency. Designed to be opened with a key or broken away. 7/8" Shackle.

PART#	DESCRIPTION
SBL66	Breakaway Brass Padlock, 7/8" Shackle



Single-use **PLASTIC PADLOCKS** must be cut or broken away. Inside shackle height is ¾". Red.

PART#	DESCRIPTION
PPL	Single Use Plastic Padlock, Red



LOCKS CONTINUED

AMERICAN LOCK® ALUMINUM PADLOCKS are spark and corrosion resistant, keyed differently with five-pin re-keyable cylinders, and case-hardened boron alloy steel shackles. Inside shackle measures 1½”H or 3”H x ¾” W.

PART#	DESCRIPTION
1106B	Aluminum Padlock, 1½” Shackle, Blue
1106R	Aluminum Padlock, 1½” Shackle, Red
1107B	Aluminum Padlock, 3” Shackle, Blue
1107R	Aluminum Padlock, 3” Shackle, Red



LOCK BOXES

Keep track of keys with this Key Box, from Brooks. It’s made of durable ABS plastic in a two-piece design that allows for easier access in an emergency. The polystyrene cover snaps right into place. Measures 4¼” x 1¼”. Red.

PART#	DESCRIPTION
BKB	ABS Key Box “Break Glass For Key”
KBRC	Replacement Plastic Cover (for BKB)



CABINET ALARMS

BASIC CABINET ALARMS for all fire extinguisher cabinets sound off with a 105 dB (measured at 1 foot) alarm when the extinguisher is removed. They are self-adhesive and install in seconds. Measures 2¾”H x 2¼”W x 1”D. **9V Battery not included.**

PART#	DESCRIPTION	W	H	D
CFAR	Cabinet Alarm, Red	2¾”	2½”	1”
CFAW	Cabinet Alarm, White	2¾”	2½”	1”



STI®’S FIRE EXTINGUISHER THEFT STOPPER helps stop theft, vandalism or misuse of fire extinguishers yet leaves the extinguisher accessible for emergencies and does not interfere with fire fighting in any way. If the protected fire extinguisher is moved from its normal position, the device emits a 105 dB piercing alarm. Also, the highly visible stop sign design and the words “STOP, EMERGENCY USE ONLY” discourages wrongful use. The device is easy to install and a deactivation cable is supplied for ease in servicing the extinguisher. **9V battery is included.**

PART#	DESCRIPTION	W	H	D
STI6200	Fire Extinguisher Theft Stopper	5¾”	5¾”	2”



STI®’S MINI THEFT STOPPER CABINET ALARM is an inexpensive yet highly effective way to protect fire extinguishers and a wide range of equipment such as fire hoses, sprinkler shutoff valves and medicine cabinets from theft. The device is compact, highly effective and extremely versatile. It does not interfere with fire fighting or use of the protected item in any way. When used as a cabinet alarm, Mini Theft Stopper (STI6254), is mounted next to the door or in the cabinet. The reed switch unit is mounted on the door jam and the matching magnet is mounted on the door across from the reed switch. When the protected cabinet door is opened the device sounds a 105dB warning horn.

PART#	DESCRIPTION	W	H	D
STI6254	Mini Theft Stopper Cabinet Alarm	3½”	3½”	1”



FIRE SAFETY PLAN BOXES

Fire Safety Plan Boxes

FIRE SAFETY PLAN BOX is made of 18-gauge Satin Coat Steel construction with stainless steel rivets and piano hinge, weather-proof door seal, overhanging sill and UV resistant decal for maximum weather protection and durability. Available in English and French and Stainless Steel construction. **Heavy duty FSPB1HD is made of 12-gauge steel.**

Includes:

- 2x Keyed alike breakaway padlocks ($\frac{7}{8}$ "") with keys
- 4x Screws and plugs (#8) for easy installation
- 6x Service Room Key Tags. (Sprinkler Room, Fire Safety Plan Box (2), Elevator, Electrical Room, Entry)

PART#	DESCRIPTION	W	H	D
FSPB1	Fire Safety Plan Box	13 $\frac{3}{8}$ "	13 $\frac{3}{8}$ "	4 $\frac{1}{4}$ "
FSPB1HD	12-Gauge Steel Heavy Duty Fire Safety Plan Box	13"	13 $\frac{1}{2}$ "	3 $\frac{1}{2}$ "
FSPB2	Fire Safety Plan Box, Mikor Lock for Region of Peel	13 $\frac{3}{8}$ "	13 $\frac{3}{8}$ "	4 $\frac{1}{4}$ "
FSPB1SS	Fire Safety Plan Box, Stainless Steel	13 $\frac{3}{8}$ "	13 $\frac{3}{8}$ "	4 $\frac{1}{4}$ "
FSPB1-BIL	Fire Safety Plan Box, Bilingual	13 $\frac{3}{8}$ "	13 $\frac{3}{8}$ "	4 $\frac{1}{4}$ "
FSPB1-FRENCH	Fire Safety Plan Box, French	13 $\frac{3}{8}$ "	13 $\frac{3}{8}$ "	4 $\frac{1}{4}$ "
FSPB2-FRENCH	Fire Safety Plan Box, French, Mikor Lock for Region of Peel	13 $\frac{3}{8}$ "	13 $\frac{3}{8}$ "	4 $\frac{1}{4}$ "
FSPPL	Replacement Brass Break-away Padlock			



FIRE EXTINGUISHER SIGNS

3D Rigid Plastic

Rigid, tough plastic ($\frac{1}{32}$ " thick) with $\frac{1}{8}$ " diameter holes for easy perpendicular wall mounting. Screen-printed with UV inks.

PART#	DESCRIPTION	W	H
PTD108	"Fire Extinguisher" Arrow, 3D Stand-Out	4"	12"
PTD109	"Fire Extinguisher" Arrow, 3D Stand-Out	4"	18"
PTD182	"Fire Extinguisher", Pictogram, 3D Stand-Out Sign	4"	12"
RSP3D56	"Fire Extinguisher" 3D Stand-Out	5"	6"



EXTINGUISHER CABINET DECALS

Vinyl Self Adhesive Signs

Self-Adhesive vinyl signs are silk screened with UV inks, then clear laminated for durability and fade resistance. Mounting surface must be clean, dry, smooth, and non-porous. To mount these on a porous surface, such as brick or concrete block, use our Sign On! Aerosol adhesive **P/N BA1**.

PART#	DESCRIPTION	W	H
BLM12	"Pull Here" For Fire Extinguisher Cabinet Covers	4"	2 $\frac{1}{2}$ "
FBLM12	French "Pull Here" For Fire Extinguisher Cabinet Covers	4"	2 $\frac{1}{2}$ "
BL253	Fire Extinguisher Cabinet and Bubble Front Decal	2"	19"
BL254	Fire Extinguisher Cabinet Decal	9"	2 $\frac{3}{8}$ "
BL106	"Fire Extinguisher - In Case of Fire Break Glass", Bilingual	6"	2"
EBL106	"Fire Extinguisher - In Case of Fire Break Glass"	6"	2"



FIRE HOSE SIGNS

Rigid Plastic

Rigid, tough plastic (1/32" thick) mounts easily to the wall with predrilled mounting holes. Screen printed with UV inks.

PART#	DESCRIPTION	W	H
PBL100	Fire Hose Pictorial, Bilingual	8"	12"
PBL101	Fire Hose and Extinguisher Pictorial, Bilingual	8"	12"
PWM125	"Fire Hose" Arrow	4"	18"



PBL100



PBL101



PWM125

Vinyl Self Adhesive Signs

Self-Adhesive vinyl signs are silk screened with UV inks, then clear laminated for durability and fade resistance. Mounting surface must be clean, dry, smooth, and non-porous. To mount these on a porous surface, such as brick or concrete block, use our Sign On! Aerosol adhesive **P/N BA1**.

PART#	DESCRIPTION	W	H
BL111	"Fire Hose"	12"	4"
BL118	"Fire Hose" Arrow	8"	12"
BL124	Hose Rack Pictorial Instructional	13"	2 3/4"
BL125	"Fire Hose" Arrow	4"	18"
BL300	"Fire Hose for use by Trained Persons Only" Reverse Label	9 3/4"	2"
BL301	"Fire Hose for use by Trained Persons Only" Reverse Label, Bilingual	9 3/4"	4"
BL303	"Fire Hose for use by Trained Persons Only"	9 3/4"	2"



BL111



BL301



BL124



BL118



BL125



BL300



BL303

NEW PRODUCT LISTING TO HELP GROW YOUR BUSINESS

Fireboy NOVEC 1230 (pg 7)

FireTech FES3 Portable Fire Extinguisher Stand (Pg 41)

12-Gauge Steel Heavy Duty Fire Safety Plan Box (Pg 50)

Sprinkler Gauge Installation Labels (Pg 66)

Mircom FA-100 Series 3 and 6 Zone Conventional Panels (Pg 88)

Kidde FX Series 5 and 10 Zone Conventional Panels English and French (Pg 88, 89)

MIR-65 Series Smoke Detector Kits (Pg 90)

Mircom FX-350 Series Intelligent Panels (Pg 90)

Kidde FX Series Intelligent Panels (Pg 91)

Booster Power Supply (Pg 92)

FX-350, FA-1000 Graphic Annunciation Modules (Pg 93)

RA-200 Mircom Annunciators (Pg 94)

Kidde FX Conventional Series Annunciators (Pg 94,95)

Mircom Manual Pull Stations Series MS-400 / 700 / 700U (Pg 96)

Mircom SD Series Smoke and Heat Combo Detectors (Pg 97)

InnovairFlex Duct Detection (Pg 98)

SuperDuct Duct Detection (Pg 98)

Mircom MIX-3000 Series Intelligent Smoke and Heat Detectors (Pg 99)

Kidde KIR Series Intelligent Smoke and Heat Detectors (Pg 99)

Intelligent Duct Detectors (Pg 100)

Intelligent Input/Output Modules (Pg 100, 101)

Intelligent Pull Stations, Mircom, Kidde, EST (Pg 101)

New Mircom 400 Series Horns, Strobes and Horn Strobes (Pg 102)

New Edwards MB Series Bells (Pg 103)

Replacement Mother Boards (Pg 104)

Smoke Alarms - New 10 Year, Battery Operated, Hardwired, Wireless (Pg 108-110)

Carbon Monoxide Alarms - New Battery Operated, Plug-In AC (Pg 110-111)

Smoke/CO Combination Alarms - New 10 Year, Battery Operated, Hardwired, Wireless (Pg 112-114)

Alarm Relay Modules & Alarm Adaptors (Pg 115)

Blowout 10 oz Detector Duster (Pg 121)

SOLO808 12ft Smoke and CO Test Starter Kit (Pg 123)

AIMP4000 Series Running Man Photoluminescent Signs (Pg 129, 154)

EBN Deluge Series Wet Location Battery Unit (Pg 132)

RMN Deluge Series Wet Location Remote Heads (Pg 133)

CRPN Deluge Series Wet Location Combo Unit (Pg 135)

RPN Deluge Series Wet Location EXIT Sign (Pg 136)

Flame Series Dated Tamper Seals (Pg 165)

Digital 99 lbs. x 10 oz. Hanging Scale (Pg 168)

Magnetic Hose Retainer (Pg 193)

Stainless Steel "Hair Pin" Clip for "VB" Heavy Duty Brackets (Pg 195)

One-Piece Safety Disc, Washer and Nut Assmely for N100 and N200QR Valves (Pg 190)

2" Tube and 1/8" Tube/Wire Compression Seal (Pg 268)

Quick Patch for Corner Pulleys (Pg 269)

Blind Compression and Quick Seal (Pg 269)

7' (84") #304 Stainless Steel Pipe (Pg 270)

7' (84") Black Pipe (Pg 271)

- FIRE HOSES
- NOZZLES
- BRASS AND HOSE VALVES



MADE IN CANADA 🍁



FIRE HOSE NOZZLES

POLYCARBONATE FIRE HOSE NOZZLES

High Impact Polycarbonate Nozzles are an economical alternative to the more expensive brass models and come with the same array of spray patterns – straight stream to fog. Ideal for locations where brass theft is a concern. 1½” nozzles are ULC listed with a maximum rated flow of 78 gallons per minute at 100 PSI (wide open). Molded in red.

1”, 2” and 2½” nozzles are not ULC listed. 1” nozzle has a maximum rated flow of 30 gallons per minute at 100 PSI (wide open). 2” and 2½” have a flow rate of 150 gallons per minute (US) at 100 PSI.

Not to be used for wash down.

PART#	DESCRIPTION
15IPT	1½” Adjustable Fog/Stream/Shut-Off, 78 gpm, NPSH
CR15IPT	1½” Adjustable Fog/Stream/Shut-Off, 78 gpm, NPSH, Chrome
15EIPT	1½” Adjustable Fog/Shut-Off Only, 78 gpm, NPSH
10IPT	1” Adjustable Fog/Stream/Shut-Off, 30 gpm, NPSH
2520-2	2” Fog/Stream/Shut-Off, 150 gpm, NPSH
2520-25CSA	2½” Fog/Stream/Shut-Off, 150 gpm, CSA
2520-25BAT	2½” Fog/Stream/Shut-Off, 150 gpm, AMA/BC
2520-25NS	2½” Fog/Stream/Shut-Off, 150 gpm, NS
NG15	Nozzle Gasket for 1½” NPSH Nozzles
103	Nozzle Gasket for 1” NPSH Nozzles



PART#	APPLICATIONS	LISTING	STYLE	GPM	HEIGHT	MATERIAL	COLOUR
15IPT	Class A:B Fires Only	ULC	Adj Fog/Stream/Shut-Off	78	4⅝”	Polycarbonate	Red
CR15IPT	Class A:B Fires Only	ULC	Adj Fog/Stream/Shut-Off	78	4⅝”	Polycarbonate	Chrome
15EIPT	Class A:B:C Electrical Fires	ULC	Adj Fog/Shut-Off	78	4⅝”	Polycarbonate	Red
10IPT	Class A:B Fires Only	None	Adj Fog/Stream/Shut-Off	30	4¾”	Polycarbonate	Red
2520-2	Class A:B Fires Only	None	Adj Fog/Stream/Shut-Off	150	5⅝”	Polycarbonate	Red
2520-25	Class A:B Fires Only	None	Adj Fog/Stream/Shut-Off	150	9”	Polycarbonate	Red

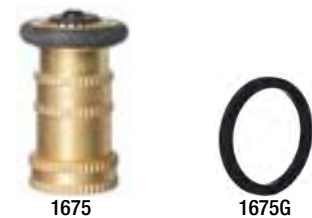


BRASS FIRE HOSE NOZZLES

Brass Fog Nozzles that are precision machined with a stain brass finish. ULC Listed and FM Approved for non-electrical fires, Class A & B Fires only.

PART#	DESCRIPTION
1675	1½” Adjustable Fog/Stream/Shut-Off, 78 gpm, NPSH, Brass
1675G	Gasket for 1½” 1675 Nozzle

PART#	APPLICATIONS	LISTING	STYLE	GPM	HEIGHT	MATERIAL	COLOUR
1675	Class A:B Fires Only	ULC	Adj Fog/Stream/Shut-Off	75	4⅝”	Brass	Brass



FIRE HOSE HYDROTEST LABELS

Our **CUSTOM FIRE HOSE HYDROSTATIC TEST LABELS** are printed with your Company Name (not shown). Company name is printed under the Date line. These labels are made of Polypropylene and come printed Bilingual. Sold 100 per roll.

PART#	DESCRIPTION	W	H
FHTL	Fire Hose Test Labels Printed with Customer Name	3”	¾”



INSPECTION TAGS

FIRE HOSE INSPECTION AND TEST RECORD tags are printed with red ink on white card stock. Sold individually.

PART#	DESCRIPTION	W	H
FHTAG	Fire Hose Inspection & Test Record Tags	2 1/8"	5 1/4"



FHTAG

FIRE HOSE

2 1/2" Provincial Thread Chart

SIZE	THREAD	DESCRIPTION	O.D.	THREADS PER INCH (TPI)
2 1/2"	BAT	Fits British Columbia (BCT) and Alberta (Alberta Mutual Aid, AMA)	3	8
2 1/2"	CSA	Ontario (Canadian Standards Association)	3.125	5
2 1/2"	NH (NST)	American Standard Fire Hose for Yukon	3.068	7.5
2 1/2"	QST	Province of Quebec Standard	3.031	7
2 1/2"	WCT	Western Canada Thread for Saskatchewan, Manitoba	3.25	6

RACK AND REEL FIRE HOSE



Polyflex® Rack and Reel Fire Hose

Polyflex® Rack and Reel Fire Hose is fully lined and FM Approved. It has an acceptance test pressure of 500 PSI and a service test of 250 PSI. Each section comes already folded for ease of installation on pin racks. Made in Canada.

Note: This inexpensive lightweight hose is designed for use as emergency fire hose only! It should never be used for washdown or any other purpose.

- Strong, compact, light in weight and will fit on most hose storage devices
- Unique Mertex® lining yields an extremely low friction loss, for maximum flow and superior adhesion for long life
- Premium all synthetic single jacket
- Brass Couplings
- Factory Mutual labeled
- Meets or exceeds all performance requirements of NFPA 1961, Underwriters Laboratories and Factory Mutual

PART#	DESCRIPTION	SHIP WEIGHT (LBS)
RH50	50 ft x 1 1/2 in. Rack Hose	7
RH75	75 ft x 1 1/2 in. Rack Hose	9
RH100	100 ft x 1 1/2 in. Rack Hose	12



Polyflex
MADE IN CANADA

TRADE SIZE	BOWL SIZE	SERVICE PRESSURE	PROOF PRESSURE	BURST PRESSURE	COUPLING	HOSE THREAD
1 1/2" (38mm)	1 1/16 (43m)	250	500	750	Brass	NPSH

SINGLE JACKET FIRE HOSE



Niagara® Single Jacket Industrial Fire Fighting Hose

Niagara® premium all synthetic Polyester fire hose has a burst pressure of 750 PSI, an acceptance test pressure of 500 PSI, a service test of 250 PSI and is FM Approved. Patented Mertex® lining process produces an amazingly thin but smooth inner waterway, yielding an extremely low friction loss for maximum flow. Made in Canada.

- Marine Fire hose and RV Potable Water (when specified potable water)
- Public Works, Parks (Hockey Rinks, Swimming Pools, etc)
- De-Contamination & Wash Down Hose
- High-Rise Hose Kits, Supply House
- Urban Interface, Forestry
- Will remain flexible to -65°F (-55°C)
- Meets or exceeds all performance requirements of NFPA 1961, Underwriter's Laboratories & Factory Mutual

PART#	DESCRIPTION	SHIP WEIGHT (LBS)
SJ5051	50 ft x 1½ in. SJ Hose, NPSH Alum Cplg	13
SJ7551	75 ft x 1½ in. SJ Hose, NPSH Alum Cplg	18
SJ10051	100 ft x 1½ in. SJ Hose, NPSH Alum Cplg	25
SJ5052BAT	50 ft x 2½ in. SJ Hose, AMA/BCT Alum Cplg	13
SJ5052CSA	50 ft x 2½ in. SJ Hose, CSA Alum Cplg	13
SJ5052QST	50 ft x 2½ in. SJ Hose, QST Alum Cplg	13
SJ5052WCT	50 ft x 2½ in. SJ Hose, WCT Alum Cplg	13
SJ10052BAT	100 ft x 2½ in. SJ Hose, AMA/BCT Alum Cplg	25
SJ10052CSA	100 ft x 2½ in. SJ Hose, CSA Alum Cplg	25
SJ10052QST	100 ft x 2½ in. SJ Hose, QST Alum Cplg	25
SJ10052WCT	100 ft x 2½ in. SJ Hose, WCT Alum Cplg	25



Niagara
MADE IN CANADA *

TRADE SIZE	BOWL SIZE	COIL DIA. (100 FT/ 30.5M)	SERVICE PRESSURE	PROOF PRESSURE	BURST PRESSURE	COUPLING	HOSE THREAD
1½" (38mm)	1¾ (44mm)	15"	250	500	750	Aluminum	NPSH
2½" (64mm)	2¾ (73mm)	16.5"	250	500	750	Aluminum	Province

DOUBLE JACKET FIRE HOSE



MD 800® Double Jacket Industrial Fire Hose

MD 800® premium all synthetic Polyester fire hose has a burst pressure of 1200 PSI, an acceptance test pressure of 800 PSI, a service test of 400 PSI. Patented Mertex® lining process produces an amazingly thin but smooth inner waterway, yielding an extremely low friction loss for maximum flow. Comes standard with aluminum couplings. Designed for normal day to day wear and tear. Made in Canada.

Available with optional Permatek HP™ treatment for greater abrasion resistance, improved visibility, reduced moisture pickup, and shorter drying times.

- Industrial Applications
- Public Works, Parks (Hockey Rinks, Swimming Pools, etc)
- De-Contamination & Wash Down Hose
- Will remain flexible to -65°F (-55°C)
- Meets or exceeds all performance requirements of NFPA 1961, Underwriter's Laboratories & Factory Mutual

PART#	DESCRIPTION	SHIP WEIGHT (LBS)
DJ5081	50 ft x 1½ in. DJ Hose, NPSH Alum Cplg	13
DJ10081	100 ft x 1½ in. DJ Hose, NPSH Alum Cplg	18
DJ5082BAT	50 ft x 2½ in. SJ Hose, AMA/BCT Alum Cplg	25
DJ5082CSA	50 ft x 2½ in. SJ Hose, CSA Alum Cplg	25
DJ5082QST	50 ft x 2½ in. SJ Hose, QST Alum Cplg	25
DJ5082WCT	50 ft x 2½ in. SJ Hose, WCT Alum Cplg	25
DJ5081Y	50 ft x 1½ in. DJ Hose, NPSH Alum Cplg, Yellow, Permatek HP	13
DJ5082YCSA	50 ft x 2½ in. DJ Hose, CSA Alum Cplg, Yellow, Permatek HP	25
DJ5082YQST	50 ft x 2½ in. DJ Hose, QST Alum Cplg, Yellow, Permatek HP	25



DJ5082Y **MADE IN CANADA** *



MADE IN CANADA * MD800

TRADE SIZE	BOWL SIZE	COIL DIA. (100 FT/ 30.5M)	SERVICE PRESSURE	PROOF PRESSURE	BURST PRESSURE	COUPLING	HOSE THREAD
1½" (38mm)	1⅞ (46mm)	15"	400	800	1200	Aluminum	NPSH
2½" (64mm)	2¾ (73mm)	16"	400	800	1200	Aluminum	Province

Steel Fire 800.387.9555

WASHDOWN HOSE



TRYME® Wash Down Hose

TRYME® Wash Down Hose is a premium synthetic double jacket hose. Designed with black polyurethane outer jacket for industrial protective applications, in chemical and petroleum environments, construction sites and general industrial use. Light weight, very high abrasion resistance and long service life. Made in Canada.

- Black polyurethane covered jacket
- Tough and ready for action and light in weight
- Unique Mertex® lining
- Premium all synthetic double jacket
- Resistant to most chemicals, petrol products, ozone and U.V. exposure, hydrolysis, and rot and mildew
- Combines the advantages of covered single jacket hose with the hydrostatic superiority of double jacket hose

PART#	DESCRIPTION	SHIP WEIGHT (LBS)
WASH50RS	50 ft x 1½ in. DJ Hose, NPSH Brass Cplg	19
WASH100RS	100 ft x 1½ in. DJ Hose, NPSH Brass Cplg	29

TRADE SIZE	BOWL SIZE	COIL DIA. (50 FT / 15.2M)	SERVICE PRESSURE	PROOF PRESSURE	BURST PRESSURE	COUPLING	HOSE THREAD
1½" (38mm)	1¾ (44mm)	14"	200	400	1200	Brass	NPSH



WASH50RS/WASH100RS
MADE IN CANADA 🇨🇦

FORESTRY FIRE HOSE



MTS-187 T2™ Forestry Hose

MTS Forestry Hose is a rugged all synthetic, single jacket Forestry Hose that comes standard with STROBE YELLOW PERMATEK™ treatment and Mercedes' "Lowest Friction Loss" lining. Patented Mertex® lining process produces an amazingly thin but smooth inner waterway, yielding an extremely low friction loss for maximum flow. Made in Canada.

- Wildland Brush Fire Truck Attack Hose
- High-Rise Hose Kits, Attack Hose
- Industrial and Forestry Applications Hose
- Cottage & Forestry Home Values Protection Hose
- Standard hose size 1.5", 1" and 1.75" also available
- Hose is available in 25', 50' and 100' lengths

PART#	DESCRIPTION	SHIP WEIGHT (LBS)
SJ5051YMTS187	50 ft x 1½ in. SJ Hose, NPSH Alum Cplg, Yellow, Permatek HP	16
SJ10051YMTS187	100 ft x 1½ in. SJ Hose, NPSH Alum Cplg, Yellow, Permatek HP	22

TRADE SIZE	BOWL SIZE	COIL DIA. (100 FT/ 30.5M)	SERVICE PRESSURE	PROOF PRESSURE	BURST PRESSURE	COUPLING	HOSE THREAD
1½" (38mm)	1 11/16" (43mm)	16.5"	300	600	900	Aluminum	NPSH



MTS-187 T2
MADE IN CANADA 🇨🇦

RUBBER COVERED FIRE HOSE



Flashflood 500® Rubber Covered Industrial Hose

Flashflood 500® Rubber Covered Industrial Hose is a lightweight layflat flexible fire hose designed for industrial fire protection. It is specifically designed to be maintenance free so it can just be wiped down and returned to service. Made in Canada.

- UL listed and can be labeled upon request in all sizes
- Colors: 1½"/38mm and 2½"/64mm black red, blue and yellow; 1¾"/45mm red and yellow; 2.0"/51mm blue
- Exceeds NFPA 1961 and UL standard performance requirements
- Maintenance free; just wipe down and return to service
- Highly resistant to fuels, chemicals, oils, heat & environmental pollutants. Impervious to molds, mildew & other airborne organisms

PART#	DESCRIPTION	SHIP WEIGHT (LBS)
ESJ1550R	50 ft x 1½ in. Rubber Hose, NPSH Alum Cplg, Red	12
ESJ15100R	100 ft x 1½ in. Rubber Hose, NPSH Alum Cplg, Red	23
ESJ1550Y	50 ft x 1½ in. Rubber Hose, NPSH Alum Cplg, Yellow	12
ESJ15100Y	100 ft x 1½ in. Rubber Hose, NPSH Alum Cplg, Yellow	23

TRADE SIZE	BOWL SIZE	COIL DIA. (100 FT/ 30.5M)	SERVICE PRESSURE	PROOF PRESSURE	BURST PRESSURE	COUPLING	HOSE THREAD
1½" (38mm)	1¾ (44mm)	12.5"	250	500	750	Aluminum	NPSH



FLASHFLOOD 500 - Red
MADE IN CANADA 🇨🇦



FLASHFLOOD 500 - Yellow
MADE IN CANADA 🇨🇦

We are in the business of growing your business

FIRE HOSE COUPLINGS, RINGS AND GASKETS

FIRE HOSE COUPLINGS

PART#	DESCRIPTION
BPRC15	1½" NPSH Brass Coupling for Rack Hose
BSJC15	1½" NPSH Brass Coupling for Single Jacket Hose
ASJC15	1½" NPSH Aluminum Coupling for Single Jacket Hose
ASJC25CSA	2½" CSA Aluminum Coupling for Single Jacket Hose
ASJC25NFLD*	2½" NFLD Aluminum Coupling for Single Jacket Hose
BDJC15	1½" NPSH Brass Coupling for Double Jacket Hose
ADJC15	1½" NPSH Aluminum Coupling for Double Jacket Hose
ADJC25AMA	2½" AMA Aluminum Coupling for Double Jacket Hose
ADJC25BC	2½" BC Aluminum Coupling for Double Jacket Hose
ADJC25CSA	2½" CSA Aluminum Coupling for Double Jacket Hose
ADJC25QST	2½" QST Aluminum Coupling for Double Jacket Hose

Contact us for any coupling requirements not listed above

* while quantities last



BPRC15 / BSJC15



ASJC15



ASJC25



BDJC15



ADJC



ADJC25

FIRE HOSE GASKETS

PART#	DESCRIPTION
1675G	Gasket for 1½" 1575B Nozzle
TG15	Tail Gasket for 1½" Coupling, 1¼" Bowl
TG15SJ	Tail Gasket for 1½" Coupling, 1¼" Bowl
DJTG15	Tail Gasket for 1½" Coupling, 1¼" Bowl
TG25	Tail Gasket for 2½" Coupling, 2¼" Bowl
SHG15	Swivel Hose Gasket for 1½" Coupling
SHG25	Swivel Hose Gasket for 2½" Coupling



1675G



Tail Gaskets



Swivel Hose Gaskets

FIRE HOSE EXPANSION RINGS

PART#	DESCRIPTION
ER15	1½" x 7/8" Rack Hose Expansion Ring
ERS1	1½" x 1¼" Single Jacket Hose Expansion Ring
ER25	2½" x 1¼" Single Jacket Hose Expansion Ring
ERD1	1½" x 1¼" Double Jacket Hose Expansion Ring
ER251	2½" x 1½" Double Jacket Hose Expansion Ring



RH & SJ Rings



DJ Rings

HOSE HANGERS, RACKS, REELS AND TRAYS

These **FireTech™ HOSE HANGERS** are constructed of aluminum alloy and conveniently accommodate 100' of lined or unlined hose, up to 2½". The top shoulder is spring loaded so that water pressure or a single pull is sufficient to release the hose. It also stores hose close to walls or columns to minimize damage as well as allowing for fewer bends in the hose, prolonging its life. Mounting instructions included.

- Hose instantly releases with a single pull
- Keeps hose close to walls or columns, minimizing damage from forklifts, etc.

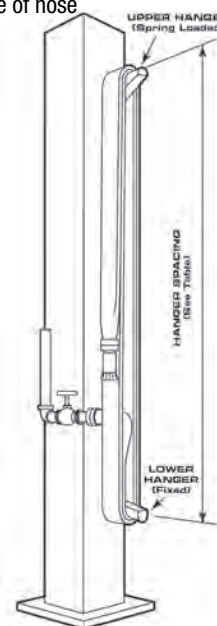
- Fewer bends and larger radiuses prolong life of hose
- Low cost and easy to install

PART#	DESCRIPTION
THH	Hose Hanger for 1½" to 2½" RH, SJ or DJ Hose



Hanger Spacing:

Hose Length	Total Loops of Hose		
	2	3	4
50'	12'	8'	6'
75'	n/a	12'	9'
100'	n/a	n/a	12'



RED ENAMELED STEEL PIN RACKS with movable pins. The automatic release mechanism keeps water from flowing into the hose while the water supply valve is opened, until the last fold is removed. This unit is ULC Listed and FM Approved.

- Red pin rack comes with Fog nozzle clip
- Includes 23 pins to accommodate 50 to 100 feet of rack hose

PART#	DESCRIPTION
HR100	Pin Rack for 75-100ft Rack Hose, ULC, 23 pin
FOGC	Fog Nozzle Clip for Pin Rack
FHWB	Wall Bracket for Pin Rack
RN	Rack Nipple c/w Nut (Steel)
RPIN	Pin for Pin Rack



MODEL S-4 SERIES PIN RACKS are used to mount 1½" (38mm) folded hose on back wall of fire protection cabinet. Typically used in conjunction with Model S-5 Water-Stop. Pins swivel 180°. Designed for rack and single jacket lined fire hoses.

- 2⅞" Long Pins
- Construction: 18-gauge metal with nickel and chrome plating
- For rack and single jacket hose only

PART#	DESCRIPTION	H	W
S421	21 pin for 1½" x 75 FT hose	2"	13¼"
S424	24 pin for 1½" x 100 FT hose	2"	15"



MODEL S-5 WATER-STOP is used with Model S4 Series pin racks to provide one-man operation of fire hose. Model S5 hose water-stop clamp allows valve to be opened with out the flow of water until the last fold is removed and hose is pulled from nozzle end. For 1½" (38mm) rack and single jacket lined hose only. ULC Listed.

- Construction: Made of 14-Gauge metal with special electrically applied black coating. Zinc Plated Single Jack chain 7" length.
- For rack and single jacket hose only

PART#	DESCRIPTION
S5	ULC Listed Water-Stop



Heavy Duty Hose Reels

Heavy Duty Hose Reels shipped assembled. Red baked enamel finish. Comes with a 14-gauge steel wall bracket that swings 180°. Accommodates 1½" diameter rack and single jacket hose.

Rugged High Capacity Heavy Duty Hose Reels have sides and hub constructed of 16-gauge steel. Welded steel 1" x ¾" reel bracket, with a 1½" x ¼" wall bracket, provides superior support. Wall bracket swings 180°. Accommodates 1½" and 2½" diameter rack, single and double jacket hose.

PART#	DESCRIPTION
HDR18	18" Hose Reel
HDR24	24" Hose Reel
HDR25HC	25" High Capacity Hose Reel

PART#	W	H	D	HOSE DIA.	RACK HOSE	SJ HOSE	DJ HOSE
HDR18	23½"	18"	6¼"	1½"	100 FT	75 FT	No
HDR24	29"	24"	6¼"	1½"	150 FT	100 FT	No
HDR25HC	29"	24"	8¾"	1½" / 2½"	300FT / 150FT	200FT / 100FT	150FT / 75FT



HDR18 / HDR24



HDR25HC

Hose Tray

HOSE TRAY is designed to take up to 100' of 1½" rack hose or 50' of 1½" industrial hose. Well constructed of heavy duty steel. Ideal for use in an area where hose may need extra protection. Hose Tray measures 15" W x 23" H x 4" D.

PART#	DESCRIPTION
HT	Hose Tray

PART#	W	H	D	HOSE DIA.	RACK HOSE	SJ HOSE
HT	15"	23"	4"	1½"	100 FT	50 FT



HT

VINYL COVERS

Vinyl Hose Reel & Rack Covers

Hose Reel and Rack Reel covers are stenciled on both sides and come with Velcro fastener. Available in English and French. English covers are stenciled "FIRE HOSE KEEP CLEAR, FOR USE BY TRAINED PERSONS ONLY" and French covers are stenciled "BOYAU D'INCENDIE". Fluorescent Red.



EHCRC18 / EHCRC24



FHRC18 / FHRC24



ERHC75 / ERHC100



FRHC75 / FRHC100

PART#	DESCRIPTION	W	H	D	APPLICATION
EHCRC18	Hose Reel Cover for 18" Dia. Reel, English	21¾"	19"	5"	Fits HDR18
FHRC18	Hose Reel Cover for 18" Dia. Reel, French	21¾"	19"	5"	Fits HDR18
EHCRC24	Hose Reel Cover for 24" Dia. Reel, English	26"	25"	5"	Fits HDR24
FHRC24	Hose Reel Cover for 24" Dia. Reel, French	26"	25"	5"	Fits HDR24
ERHC75	Cover for 75ft Hose Pin Rack, English	21"	24"	5"	Pin racks w/ 75 ft hose
FRHC75	Cover for 75ft Hose Pin Rack, French	21"	24"	5"	Pin racks w/ 75 ft hose
ERHC100	Cover for 100ft Hose Pin Rack, English	21"	30"	5"	Pin racks w/ 100 ft hose
FRHC100	Cover for 100ft Hose Pin Rack, French	21"	30"	5"	Pin racks w/ 100 ft hose

HEAVY DUTY COVERS

HD Hose Reel & Rack Covers

Heavy Duty Hose Reel covers are made of acrylic coated polyester. These covers have a much longer lifespan in harsh conditions. HD Hose Reel and Rack Reel covers are stencilled on both sides and come with Velcro fastener. Available in English and French. English covers are stencilled "FIRE HOSE KEEP CLEAR, FOR USE BY TRAINED PERSONS ONLY" and French covers are stencilled "BOYAU D'INCENDIE". Fluorescent Red.

PART#	DESCRIPTION	W	H	D	APPLICATION
EHDC25	Hose Reel cover for 24" High Capacity Reel, English	29"	24"	8¾"	HDR25HC
FHDC25	Hose Reel cover for 24" High Capacity Reel, French	29"	24"	8¾"	HDR25HC



EHDC25



FHDC25

HOSE VALVES

ANGLE HOSE VALVES

1½" Fire Hose Valves are made of forged brass for use with pin rack assembly. Valves come with hydro drain vent. Tested to 300 PSI. ULC Listed. CHROME VALVES AVAILABLE AS SPECIAL ORDER.

PART#	DESCRIPTION
FM150	1½" NPSH Female x Male Angle Valve, ULC
FF150	1½" NPSH Female x Female Angle Valve, ULC
HWV7	Handwheel for ¼" Angle Valve Stem



FM150



FF150



HWV7

GATED WYE VALVES

These quality **GATED WYE LEADER LINE SIAMESE** come with Delrin ball valves built into the body so that either lead can be used independently of the other. Gated Wyes feature 2½" female swivel inlets and 1½" male outlets. The 2.5" Swivel inlet is available in all the standard Canadian Thread as well as in NH. The 1.5" male outlets as available in both NPSH, NH, Quick Connect (QC) and other sizes and treads available upon special request. This unit features a cast brass Aluminum body with both the Rocker Lug Female swivel and the male outlets made of Hard anodized aluminum.

The 1.5" version is unpainted
The 2.5" version is painted Red

PART#	DESCRIPTION	Weight (lbs)
70FL15GYPS	Gated Wye - 1½" Female NPSH by two 1½" Male NPSH	3.25
70FL15GYNH	Gated Wye - 1½" Female NH (NST) by two 1½" Male NH (NST)	3.25
70FL15GYQC	Gated Wye - 1½" Forged Quick Connect	3.89
70FL15GYPS10PS	Gated Wye - 1½" Female NPSH by two 1" Male NPSH	3.25
70FL15GYNH10PS	Gated Wye - 1½" Female NH (NST) by two 1" Male NPSH	3.25
70FL25GYCS15PS	Gated Wye - 2½" Female CSA by two 1½" Male NPSH	4.69
70FL25GYBA15PS	Gated Wye - 2½" Female BCT /AMA by two 1½" Male NPSH	4.69
70FL25GYQS15PS	Gated Wye - 2½" Female QST by two 1½" Male NPSH	4.69
70FL25GYME15PS	Gated Wye - 2½" Female N. Scotia Zone 1 by two 1½" Male NPSH	4.69
70FL25GYNH15NH	Gated Wye - 2½" Female NH (NST) by two 1½" Male NH (NST)	4.69
70FL25GYNH15PS	Gated Wye - 2½" Female NH (NST) by two 1½" Male NPSH	4.69



70FL15GYPS



70FL15GYQC



70FL25GYBA15PS



Wye with Quick Connect Outlet Option

ADAPTERS, CAPS AND PLUGS

BRASS CAPS, PLUGS AND REDUCERS

Brass Caps

Brass Caps used with fire department connections, hydrants, valves, etc. to hold back water. CHROME AVAILABLE ON REQUEST.

PART#	DESCRIPTION	TRADE SIZE	THREAD
1500B	1½" IPT Threaded Cap w/ Chain	1½"	IPT/NPSH
2500BAMABC	2½" BAT Threaded Cap w/ Chain	2½"	BAT (AB, BC)
2500BCSA	2½" CSA Threaded Cap w/ Chain	2½"	CSA (ON)
2500BQST	2½" QST Threaded Cap w/ Chain	2½"	QST
2500BWCT	2½" WCT Threaded Cap w/ Chain	2½"	WCT (SK, MB)
2500B1NFLD	2½" NFLD Threaded Cap w/ Chain	2½"	NFLD
2500B1NS	2½" NS Threaded Cap w/ Chain	2½"	NS



1500B



2500B

Brass Plugs

Brass Plugs used with fire department inlet connections, siamese, single inlet, etc. to keep inlet ports free of debris. CHROME AVAILABLE ON REQUEST.

PART#	DESCRIPTION	TRADE SIZE	THREAD
2500BPAMABC	2½" BAT Threaded Brass Plug w/ Chain	2½"	BAT (AB, BC)
2500BPCSA	2½" CSA Threaded Brass Plug w/ Chain	2½"	CSA (ON)
2500BPQST	2½" QST Threaded Brass Plug w/ Chain	2½"	QST
2500BPWCT	2½" WCT Threaded Brass Plug w/ Chain	2½"	WCT (SK, MB)
2500BP1NFLD	2½" NFLD Threaded Brass Plug w/ Chain	2½"	NFLD
2500BP1NS	2½" NS Threaded Brass Plug w/ Chain	2½"	NS



2500BP

Brass Reducers

Brass reducer, Female x Male pin lug adapter (used to change size and/or threads). Reduces 2½" thread to 1½" NPSH. CHROME AVAILABLE ON REQUEST.

PART#	DESCRIPTION	TRADE SIZE	THREAD
250150AMABC	2½" BAT F X 1½" NPSH M Brass Reducer	2½" X 1½"	BAT (AB, BC)
250150CSA	2½" CSA F X 1½" NPSH M Brass Reducer	2½" X 1½"	CSA (ON)
250150QST	2½" QST F X 1½" NPSH M Brass Reducer	2½" X 1½"	QST
250150WCT	2½" WCT F X 1½" NPSH M Brass Reducer	2½" X 1½"	WCT (SK, MB)
2501501NFLD	2½" NFLD F X 1½" NPSH M Brass Reducer	2½" X 1½"	NFLD
2501501NS	2½" NS F X 1½" NPSH M Brass Reducer	2½" X 1½"	NS



250150

PLASTIC CAPS

Plastic caps and chains are an inexpensive way to protect hydrant threads and a viable replacement for brass caps when theft is an issue. **U250** pushes/pulls on and off all provincial 2½" outlets. Models **B150** and **B250** thread on. Red.

PART#	DESCRIPTION
U250	2½" Push On Cap w/Chain, Universal
B150	1½" NPSH (IPT) Threaded Cap w/Chain
B250CSA	2½" CSA Threaded Cap w/Chain
B250CCSA	2½" CSA Threaded Cap w/Chain, Chromed Finish



U250

B150

B250CSA

PLASTIC BREAK CAPS

The most economical way to protect fire dept. connection inlets is with **PLASTIC BREAK CAPS**. The **PAC** uses an adjustable bar that threads onto any hose thread. The PAC fits 2½” inlets and are easily broken with a hydrant/spanner wrench. Red. The **PBC** uses eye bolts and j-hooks to secure the cap via the inlet’s pin lugs. The PBC fits 2½” inlets and is easily broken with a hydrant/spanner wrench. Red.

PART#	DESCRIPTION
PAC	Adjust-A-Plug Plastic Break Cap
PBC	2½” Molded Plastic Break Cap c/w J Hooks



MUNICIPAL HAND TOOLS

MUNICIPAL WRENCHES

Designed for today’s fire department connections, this assortment of quality **WRENCHES** cover all the popular sizes and styles in storz and threaded adapters (pin or rocker lugs).

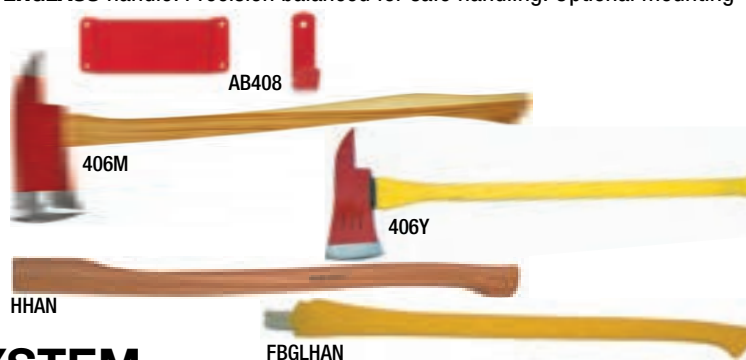
PART#	DESCRIPTION	MATERIAL
STW	Storz x Universal Spanner (Fits 4”-6” Storz, 1½” to 3” Rocker Lugs)	Forged Aluminum
AFS	Folding Pocket Spanner Wrench (Fits Pin/Rocker Lugs thru 4”)	Plastic
150W	Universal Spanner Wrench (Fits 1½” Pin/Rocker Lugs)	Forged Aluminum
250W	Universal Spanner Wrench (Fits 1½” to 3” Pin/Rocker Lugs)	Forged Aluminum
250K	Universal Spanner Wrench (Fits 1½” to 3” Pin/Rocker Lugs) with Gas Key Shut-off	Forged Aluminum
250H	Combination Hydrant Key / Spanner Wrench (Fits 1½” to 3” Pin/Rocker Lugs)	Forged Aluminum
W575	Adjustable Combination Hydrant/Spanner Wrench (Fits 1½” to 6” Pin/Rocker Lugs), Heavy Duty	Steel/Ductile Iron
W580	Adjustable Combination Hydrant/Spanner Wrench (Fits 1½” to 6” Pin/Rocker Lugs)	Steel/Ductile Iron



FIRE AXES

PICK HEAD FIRE AXE with a 6 lb. head and available with **HICKORY** or **FIBERGLASS** handle. Precision balanced for safe handling. Optional mounting bracket and hook available separately.

PART#	DESCRIPTION
406M	6 lb. Pick Head Axe, 36” Hickory Handle
406Y	6 lb. Pick Head Axe, 34” Yellow Fiberglass Handle
AB408	Axe Bracket and Hook
HHAN	Hickory Handle for Model 406 Axe, 36”
FBGLHAN	Fiberglass Handle for Model 406 Axe, 34”



BACKPACK EXTINGUISHING SYSTEM

The Genfo-45 wildland backpack extinguishing system features a large 4½ gal reservoir and internal baffle for a substantial yet stable transportable water supply. It also includes a double-action hand pump and a 40” x ¼” bsp hose with a fully adjustable nozzle, a carry handle, and shoulder straps for easy transportation. Weighs 4 lbs empty and measures 25½” H x 19½” W x 1” D. Special Order

PART#	DESCRIPTION
WBES45	Genfo-45 Water Backpack
WBES45FT	Foam Application Tube for Genfo-45



FIRE HOSE SIGNS

Rigid Plastic

Rigid, tough plastic ($\frac{1}{32}$ " thick) mounts easily to the wall with predrilled mounting holes. Screen printed with UV inks.

PART#	DESCRIPTION	W	H
PBL100	Fire Hose Pictorial, Bilingual	8"	12"
PBL101	Fire Hose and Extinguisher Pictorial, Bilingual	8"	12"
PWM125	"Fire Hose" Arrow	4"	18"



PBL100



PBL101



PWM125

Vinyl Self Adhesive Signs

Self-Adhesive vinyl signs are silk screened with UV inks, then clear laminated for durability and fade resistance. Mounting surface must be clean, dry, smooth, and non-porous. To mount these on a porous surface, such as brick or concrete block, use our Sign On! Aerosol adhesive **P/N BA1**.

PART#	DESCRIPTION	W	H
BL111	"Fire Hose"	12"	4"
BL118	"Fire Hose" Arrow	8"	12"
BL124	Hose Rack Pictorial Instructional	13"	2 $\frac{3}{4}$ "
BL125	"Fire Hose" Arrow	4"	18"
BL300	"Fire Hose for use by Trained Persons Only" Reverse Label	9 $\frac{3}{4}$ "	2"
BL301	"Fire Hose for use by Trained Persons Only" Reverse Label, Bilingual	9 $\frac{3}{4}$ "	4"
BL303	"Fire Hose for use by Trained Persons Only"	9 $\frac{3}{4}$ "	2"



BL111



BL300



BL118



BL125



BL301



BL303



BL124

- **SPRINKLER ACCESSORIES**
- **STANPIPE EQUIPMENT**



SPRINKLER ACCESSORIES AND STANPIPE EQUIPMENT

SPRINKLER GAUGES

SPRINKLER GAUGES are manufactured to exact standards, with only the finest materials, for maximum performance year in and year out. Designed for use on wet or dry sprinkler systems. UL listed and FM approved. SG1 is used in a dry system on the sprinkler head side of the control valve to accurately monitor line air pressure, with the ability to accept water pressure up to 250 psi (upon system activation). The SG2 is used on the water supply side of the sprinkler system to show available source pressure. The SG3 accommodates both air and water sides, up to 300 psi.

Plastic Backed GAUGES (3½")

PART#	DESCRIPTION
SG1	Air/Water/Retard Gauge, 0-80/250 psi
SG2	Water Gauge, 0-300 psi
SG3	Air/Water Gauge, 0-300 psi



Sprinkler Gauge Installation Labels help your customers comply with the AHJ by showing that sprinkler gauges have been tested/replaced within five years (per NFPA 25). They include spaces to record the installation date (different from the manufacturer date) and the date to test/replace the gauge. Roll/300.

PART#	DESCRIPTION
SGIL	Sprinkler Gauge Installation Label, Roll/300



REPLACEMENT SPRINKLER HEADS

- ULC & FM approved
- Available in temperature ratings from 155° to 360°
- 5mm glass bulb sprinklers ½" orifice x ½" NPT
- K FACTOR 5.6
- Standard Response
- ¾" Available Upon Request

PART#	DESCRIPTION
J155P	155° Pendant Bulb, ½" IPS, Brass, Std Response
J155U	155° Upright Bulb, ½" IPS, Brass, Std Response
J155PC	155° Pendant Bulb, ½" IPS, Chrome, Std Response
J155UC	155° Upright Bulb, ½" IPS, Chrome, Std Response
J200P	200° Pendant Bulb, ½" IPS, Brass, Std Response
J200U	200° Upright Bulb, ½" IPS, Brass, Std Response
J200PC	200° Pendant Bulb, ½" IPS, Chrome, Std Response
J200UC	200° Upright Bulb, ½" IPS, Chrome, Std Response
J286P	286° Pendant Bulb, ½" IPS, Brass, Std Response
J286U	286° Upright Bulb, ½" IPS, Brass, Std Response
J286PC	286° Pendant Bulb, ½" IPS, Chrome, Std Response



ESCUTCHEONS

Escutcheon Plate with Springs

The heavy-duty Split version uses springs to perfectly center the escutcheon on pipe and sprinkler heads. It is also ideal for installation around existing heads. Chrome plated.

- Split heavy duty wall plate
- Spring Inserts that grip the pipe
- Triple Chrome Plated
- Heavy Gauge Steel
- Available to 10" IPS

PART#	DESCRIPTION	FINISH	SIZE	OD
EP650	Split Escutcheon Plate with Springs	Chrome	½" IPS	2¾"



Escutcheon, One-Piece (Light Gauge)

- Available in ½" and ¾" IPS in chrome, white and brass finishes
- Overall 2⅞" coverage and ⅝" deep

PART#	DESCRIPTION	FINISH	SIZE
EPC	Escutcheon, One Piece (Light Gauge)	Chrome	½" IPS



SPRINKLER ACCESSORIES

SPRINKLER WRENCHES for sprinkler heads.

PART#	DESCRIPTION
SPWR	Sprinkler Wrench for 1/2" Heads



SPWR

SPRINKLER CAGE made of heavy wire construction, finished Red.

- One-piece, 2 hook head guard without shield
- Fits most 1/2" and 3/4" IPS sprinklers
- Red, Chrome & White Finish
- Heavy wire construction

PART#	DESCRIPTION	FINISH	SIZE	HEIGHT
SPG	Economy Sprinkler Guard, Red	Red	Fits 1/2" - 3/4" IPS	3 1/4"



SPG

Spare **SPRINKLER HEAD CABINETS** help you meet code requirements. This cabinet will hold up to 6 heads and a wrench. Each cabinet is constructed from steel with a red enamel finish and accommodates 1/2" and 3/4" heads as well as most sprinkler wrenches. Pre-drilled rear mounting holes for easy wall mounting. Red.

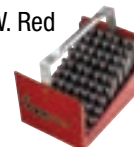
PART#	DESCRIPTION	L	H	W
SHC1	6-Head Cabinet	14"	2 1/2"	5"



SHC1

Strong yet lightweight, the FireTech™ **NIPPLE TOTE BOX** holds 3/8" and 1/2" nipples (close to 6") and features a fold-away handle for easy storage. Made of 18 ga steel with a red enamel finish and 77 compartments. Measures 10 5/8" L x 6 1/2" H x 7 3/8" W. Red

PART#	DESCRIPTION	L	H	W
PNT1	Nipple Tote Box	10 5/8"	6 1/2"	7 3/8"



PNT1 in Use

The FireTech™ **FITTINGS TOTE TRAY** is ideal for organizing and carrying a wide variety of fittings. Manufactured from 18 ga epoxy-coated steel for superior durability and strength, it comes with seven compartments and features a fold-away handle for easy storage. Measures 15" L x 5" H x 10" W. Red.

PART#	DESCRIPTION	L	H	W
PFT2	Fittings Tote Tray	15"	5"	10"



PFT2 in Use

VALVE TAMPER SEALS

The **HEAVY-DUTY VALVE TAMPER SEALS** are both deterrents and indicators of the unauthorized opening or closing of the sprinkler system valves. They meet the installation requirements of NFPA 13 and inspection requirements of NFPA 25 for sprinkler systems too. (Attach seals to valves in a manner that the valves cannot be operated without breaking the seals.) Each seal is stamped with a 7-digit serial number that can be recorded to show who performed the installation, inspection, or maintenance. IMPRINT SEAL is available with 3-lines, 8 characters per line. Minimum 5000. Matted in strips of 10 for ease-of use. Sold in boxes of 1000.

NOTE: When seals are used, valves should be inspected weekly.

PART#	DESCRIPTION
HDVTS18	Heavy-Duty Valve Tamper Seals, 18", 1000/Box



HDVTS18 in Use

SPRINKLER IDENTIFICATION SIGNS

Aluminum

Sprinkler Identification Signs are made of aluminum, painted white, and printed with fade-resistant red ink. Each sign has predrilled mounting holes for easy installation.

NOTE: Signs are shipped with removable plastic film to prevent scratching, unless otherwise noted.

PART#	DESCRIPTION	W	H
A142 *	This Valve Controls	6"	4"
A143	Control Valve	6"	2"
A160	Inspection Test	6"	2"
A161	Main Drain	6"	2"
A162	Sprinkler Drain	6"	2"
A163	Alarm Test	6"	2"
A164 *	Hydraulic Data	6"	4"
A165	Sprinkler Fire Alarm	7¼"	6"
A221	Air Control	6"	2"
A222	Air Line	6"	2"
A223	Alarm Line	6"	2"
A224	Anti-Freeze System	6"	2"
A225	Auxiliary Drain	6"	2"
A226	This Valve Controls	9"	7"
A227	Drain	6"	2"
A228	Drain Valve	6"	2"
A229	Dry Standpipe	6"	2"
A230 *	Entire System	6"	2"
A232	Hydraulic System	5"	7"
A233	Main Control	6"	2"
A234	Normally Closed	6"	2"
A235	Normally Open	6"	2"
A236	Open Sprinkler Control	6"	2"
A237	Open Sprinkler Drain	6"	2"
A238	Sprinkler Valve Room	6"	2"
A239	Test & Drain	6"	2"
A240	Test Valve	6"	2"
A241	Water Motor Line	6"	2"
A242	Wet Standpipe	6"	2"
A243	Fire Sprinkler Valve	6"	2"

* This sign does not have plastic coating to prevent scratching



A142



A143



A160



A164



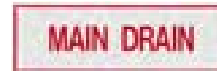
A165



A226



A232



A161



A163



A222



A224



A227



A229



A233



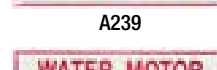
A235



A237



A239



A241



A162



A221



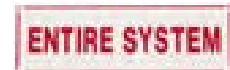
A223



A225



A228



A230



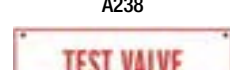
A234



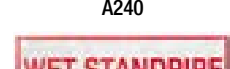
A236



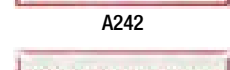
A238



A240



A242



A243

Rigid Plastic

Sprinkler Alarm Signs are made of plastic, painted red, and printed with fade-resistant white ink. Each circular sign has a predrilled mounting hole for easy installation over alarm bell. 7" Dia.

PART#	DESCRIPTION	Dia.
RP251	911 Fire Alarm Bell, Plastic	7"



RP251

Vinyl Self Adhesive Signs

Fire Sprinkler Labels, with arrow, are printed with fade-resistant red ink on white self-adhesive vinyl. Use them to identify sprinkler lines and direction of water flow. Rolls of 50 labels. 6" L x 2" H.

PART#	DESCRIPTION	W	H
BL252L	"Fire Sprinkler Line" with Left Arrow	6"	2"
BL252R	"Fire Sprinkler Line" with Right Arrow	6"	2"



BL252L



BL252R

FIRE DEPARTMENT AND SYSTEM SIGNS

Aluminum

Aluminum signs have smooth finished edges, rounded corners and predrilled mounting holes. Silk screened and then oven baked for long lasting durability.

PART#	DESCRIPTION	W	H
A245	"FDC" w/ Arrow, 4" Letters	12"	10"
A244	"Fire Department Connection"	4"	6"



A245



A244

FIRE SPRINKLER MONITORING

ALARM PRESSURE SWITCHES

System Sensor EPSA10 Series

System Sensor **EPSA10 Series** field-adjustable pressure switches are designed for use in wet, dry, deluge and pre-action automatic sprinkler systems to indicate a discharge from a sprinkler.

PART#	DESCRIPTION
EPSA10-1P	Alarm Pressure Switch, One SPDT, Plastic Fitting
EPSA10-2P	Alarm Pressure Switch, Two SPDT, Plastic Fitting



EPSA10-1P

System Sensor EPSA40 Series

System Sensor **EPSA40 Series** supervisory field-adjustable pressure switches are intended for dry pipe systems or pressure tanks and water supplies of automatic water control valves. This model offers a choice of initiating low or high/low pressure monitoring alarms, in a variety of pressure ranges.

PART#	DESCRIPTION
EPSA40-1P	Low Pressure Supervisory Switch, One SPDT, 10–100 PSI - Plastic Fitting
EPSA40-2P	High/Low Pressure Supervisory Switch, Two SPDT, 10–100 PSI - Plastic Fitting

System Sensor EPSA120 Series

System Sensor **EPSA120 Series** supervisory field-adjustable pressure switches are intended for dry pipe systems or pressure tanks and water supplies of automatic water control valves. This model offers a choice of initiating low or high/low pressure monitoring alarms, in a variety of pressure ranges.

PART#	DESCRIPTION
EPSA120-1P	Low pressure supervisory switch, one SPDT, 10–200 PSI
EPSA120-2P	High/Low pressure supervisory switch, two SPDT, 10–200 PSI

ATTRIBUTE	SPECIFICATION					
Item #	EPSA10-1P	EPSA10-2P	EPSA40-1P	EPSA40-2P	EPSA120-1P	EPSA120-2P
Type of Pressure Switch	Alarm Waterflow	Alarm Waterflow	Supervisory Low	Supervisory High/Low	Supervisory Low	Supervisory High/Low
Switch Type	1 SPDT	2 SPDT	1 SPDT	2 SPDT	1 SPDT	2 SPDT
Listing	ULC, FM	ULC, FM	ULC, FM	ULC, FM	ULC, FM	ULC, FM
Enclosure Rating	NEMA 4	NEMA 4	NEMA 4	NEMA 4	NEMA 4	NEMA 4
PSI Range	4-20	4-20	10-100	10-100	10-200	10-200

SUPERVISORY SWITCHES

System Sensor Supervisory Switches

System Sensor's electric supervisory switches are used to monitor the open position of Outside Screw and Yoke (OS&Y) type gate valves, post indicator and butterfly control valves (PIBV2A) and other type of valves. System Sensor's PSP1A plug-in switch is a special application supervisory switch designed for applications where no other type of listed valve supervisory switch can be used. Each feature a NEMA 3R-rated enclosure that is also tamper resistant. ULC listed and FM approved.

PART#	DESCRIPTION
OSY2A	Outside Screw and Yoke valve supervisory switch
PIBV2A	Post Indicator/Butterfly valve supervisory switch
PSP1A	Plug-in Special Purpose Supervisory Switch



OSY2A



PIBV2A



PSP1A

WATERFLOW DETECTORS

System Sensor WFDNA Series

The WFDNA Series waterflow detectors from System Sensor consists of a rugged, NEMA 4-rated enclosure that is more damage resistant than previous metal designs. The waterflow detector is designed for both indoor and outdoor use, with the widest available temperature range, from 0°C to 66°C (32°F to 150°F). The System Sensor WFDNA series is compatible with schedule 7 through 40 steel pipe, for sizes 2 in. through 4 in. and compatible with schedule 10 through 40 steel pipe, sizes 6 in. through 8 in., and can be mounted in a vertical or horizontal position.

PART#	DESCRIPTION
WFD20NA	2" Waterflow detectors
WFD25NA	2.5" Waterflow detectors
WFD30NA	3" Waterflow detectors
WFD40NA	4" Waterflow detectors
WFD50NA	5" Waterflow detectors
WFD60NA	6" Waterflow detectors
WFD80NA	8" Waterflow detectors



WFD25NA



WFDNA

ATTRIBUTE	SPECIFICATION						
Item #	WFD20NA	WFD25NA	WFD30NA	WFD40NA	WFD50NA	WFD60NA	WFD80NA
Switch Type	2 SPDT	2 SPDT	2 SPDT	2 SPDT	2 SPDT	2 SPDT	2 SPDT
Listing	ULC	ULC	ULC	ULC	ULC	ULC	ULC
Enclosure Rating	NEMA 4	NEMA 4	NEMA 4	NEMA 4	NEMA 4	NEMA 4	NEMA 4
Fits Schedule Piping	7 through 40	7 through 40	7 through 40	7 through 40	10 through 40	10 through 40	10 through 40
Pipe Size	2"	2½"	3"	4"	5"	6"	8"
Hole Size	1¼"	1¼"	2"	2"	2"	2"	2"

- **LOCK-OUTS**
- **SAFETY PRODUCTS**
- **STORAGE CABINETS**



LOCKOUT TAGOUT

Lockout Tags

LOCKOUT TAGS measure 3" x 5¾" and are made of rugged, stain and mildew-resistant .020 styrene. Grommets are standard on tags for greater strength. All tags have the "DANGER" heading, striped red border, and come with zip ties. The textured surface allows you to write your name and other important information easily. Sold in packages of 25.

PART#	DESCRIPTION
ELA290	"Do Not Operate", Pkg/25
ELA255	"Do Not Open", Pkg/25
ELA250	"Do Not Start", Pkg/25



ELA290



ELA255



ELA250

Lockout Hasps

Safety **LOCKOUT HASPS** provide a safe, proven method of locking out energy sources. Two models are available: the red heavy-duty nylon style or the aluminum scissors type. The nylon model is flexible, unbreakable, dielectric, and heat and cold resistant. The aluminum models have rubber-dipped handles and are available with two different jaw-opening sizes. Both models accommodate up to six padlocks.

PART#	DESCRIPTION	MATERIAL
MS01	Lockout Hasp	Nylon
OG80	Lockout Hasp, 1"	Aluminum
OG82	Lockout Hasp, 1½"	Aluminum



MS01



OG80

Rotating Gate Valve Lockouts

Ideal for tight spaces and insulated pipes, **MASTER LOCK® ROTATING GATE VALVE LOCKOUTS** come in various diameters to fit over different size valve handles. They can be locked to protect against accidental opening and feature tough yet lightweight dielectric ZENEX™ thermoplastic construction, which easily withstands chemicals and temperature extremes. Their unique, patented rotating design is also what makes it easy to fit them in tight spaces. Hi-vis safety labels come in English, French, and Spanish, and the center knockout can be removed to fit over a rising stem gate valve.

PART#	DESCRIPTION
ML480	Gate Valve Lockout 1"-3" Dia.
ML481	Gate Valve Lockout 2"-5" Dia.
ML482	Gate Valve Lockout 4"-6½" Dia.



ML480



ML481



ML482

Pressurized Gas Valve Lockout

The **MASTER LOCK® PRESSURIZED GAS VALVE LOCKOUT** fits most pressurized gas valve handles up to 3" in diameter. This patented product is designed to work with the valve guard in place too. It also works with multiple lockout hasps and accepts any **MASTER LOCK®** or **AMERICAN LOCK®** safety padlocks.

PART#	DESCRIPTION
MLS3910	Pressurized Gas Valve Lockout (Lock Not Included)



MLS3910

Circuit Breaker Lockouts

Circuit Breaker Lockouts are made of tough, molded plastic. Available to fit single and double pole breakers. **CB03** can be used with all single pole breakers without the through hole. **CB01** fits all Square-D-style and many other popular breakers with a padlock hole through the breaker toggle. The smaller **CB04** can be used where space is a concern. **CB02** fits ITE and Westinghouse-style double pole breakers.

PART#	DESCRIPTION	APPLICATION	STYLE	MATERIAL
CB03	Single Pole Lockout	Fits single pole breakers without the through hole	For Toggles w/out Hole	Plastic
CB01	Single Pole Lockout	Fits all Square-D-style and many other popular breakers with a padlock hole through the breaker toggle	For Toggles w/ Hole	Plastic
CB04	Double Pole Lockout	Smaller CB04 can be used where space is a concern	For Toggle Switch w/out Cross Bar	Plastic
CB02	Double Pole Lockout	Fits ITE and Westinghouse-style double pole breakers	For Breaker w/ Cross Bar	Plastic



LOCKS

LAMINATED PADLOCK, from **Master Lock®**, features a four-pin cylinder nickel-plated steel body and hardened steel shackle. Shackle is 1/4" thick with an inside measure 7/8" x 1 1/16". All locks are keyed differently. Ideal for group lock box and high-security applications.

PART#	DESCRIPTION
L40	Laminated Padlock, 7/8" Shackle



Corrosion-resistant **BASIC PADLOCK** features an all brass shackle, making it ideal for cabinets and other security requirements where economy and keyed-alike convenience is essential. 5/8" Shackle.

PART#	DESCRIPTION
M12L	Brass Padlock Keyed Alike, 5/8" Shackle



MASTER LOCK® is a name synonymous with top-quality padlocks. The keyed-alike **BREAKAWAY STEEL PADLOCK** has a 1 3/4"-wide laminated steel body for superior strength and comes with two keys, a steel shackle for strong cut resistance, and a warded locking mechanism that helps minimize jamming from foreign matter, like dirt and grime. And it's rustproof for extended wear.

PART#	DESCRIPTION
ML500KA	Keyed-Alike Breakaway Steel Padlock, 1 3/16" Shackle



BREAKAWAY BRASS PADLOCK is for securing cabinets and other equipment until needed in an emergency. Designed to be opened with a key or broken away. 7/8" Shackle.

PART#	DESCRIPTION
SBL66	Breakaway Brass Padlock, 7/8" Shackle



Single-use **PLASTIC PADLOCKS** must be cut or broken away. Inside shackle height is $\frac{3}{4}$ " . Red.

PART#	DESCRIPTION
PPL	Single Use Plastic Padlock, Red



AMERICAN LOCK® ALUMINUM PADLOCKS are spark and corrosion resistant, keyed differently with five-pin re-keyable cylinders, and case-hardened boron alloy steel shackles. Inside shackle measures $1\frac{1}{2}$ "H or 3"H x $\frac{3}{4}$ " W.

PART#	DESCRIPTION
1106B	Aluminum Padlock, $1\frac{1}{2}$ " Shackle, Blue
1106R	Aluminum Padlock, $1\frac{1}{2}$ " Shackle, Red
1107B	Aluminum Padlock, 3" Shackle, Blue
1107R	Aluminum Padlock, 3" Shackle, Red



TRANSPORT OF DANGEROUS GOODS PRODUCTS

CYLINDER VALVE GUARD and **CAP** meets DOT, OSHA, and MSHA requirements. **GT11** can be fitted and padlocked over cylinder valve with regulator attached. The **CCAP** can be fitted over cylinder valves only. Measures $3\frac{3}{8}$ " x 11 threads per inch.

PART#	DESCRIPTION
GT11	Cylinder Valve Guard
CCAP	Cylinder Cap



CYLINDER RACK SYSTEM can be used to meet DOT 49CFR, section 177.840 requirement for transporting compressed gas cylinders. Series E horizontal track (SKU# ETK) is finished with a gray primer, ready to install. The 2" cylinder belt straps (SKU# CB1 or CB2) come with ratchet buckle and spring-loaded fittings.

RATCHET RATINGS:	STRAP RATINGS:	SPRING-LOADED END FITTINGS RATINGS:
<ul style="list-style-type: none"> Working Load Limit: 1000 lbs. Breaking Strength: 3000 lbs. 	<ul style="list-style-type: none"> Working Load Limit: 2000 lbs. Breaking Strength: 6000 lbs. 	<ul style="list-style-type: none"> Working Load Limit: 1000 lbs. Working Load Limit: 3000 lbs.

PART#	DESCRIPTION
ETK	5ft Section E-Track
CB1	Cylinder Belt, 23" Fixed x 6 ft Adjustable
CB2	Cylinder Belt, 6" Fixed x 3 ft Adjustable



FIRE PROTECTION AND EQUIPMENT LOG BOOKS

2 YEAR FIRE PROTECTION LOG for recording Maintenance, Inspections, Tests, Repairs, etc. Complete with sections covering:

- Emergency Power Generator
- Voice Communication
- Fire Extinguishers
- Standpipe System
- Emergency Lighting
- Fire Fighters Elevators
- Fire Alarms
- Sprinklers

PART#	DESCRIPTION
298A	Fire Protection Equipment Log, English
298F	Fire Protection Equipment Log, French



MODEL 299 is a **FIRE EXTINGUISHER LOG BOOK** for recording monthly inspections, annual maintenance and recharges. These coil bound books (plastic covers) have the capacity to record up to 900 Extinguishers for 1 year or can be used for a number of years if fewer units are logged. Contains information pertaining to classes of fire and current Fire Extinguisher regulations. Fulfills requirements of current fire code.

PART#	DESCRIPTION
299	Fire Extinguisher Log Book, English



299

EQUIPMENT MAINTENANCE LOG BOOKS Can be used to track the following information:

- Date
- Equipment Adjustment or Repair
- Time
- Signature

PART#	DESCRIPTION
705	Equipment Log Book, English
705F	Equipment Log Book, French



705



705F

CODES AND REGULATIONS

NFPA PUBLICATIONS CODES & REGULATIONS. Keep your service and sales teams informed by keeping a current copy of the NFPA standards at work.

PART#	DESCRIPTION
NFPA1018	NFPA 10: Standard for Portable Fire Extinguishers – 2018 ed.
NFPA1717	NFPA 17: Standard for Dry Chemical Extinguisher Systems - 2017 ed.
NFPA17A17	NFPA17A: Standard for Wet Chemical Extinguisher Systems - 2017 ed.
NFPA9617	NFPA 96 Standard for Ventilation Control & Fire Protection of Commercial Cooking Operations, 2017 ed.
NFPA10118	NFPA 101: Life Safety Code© - 2018 ed.
NFPA7219	NFPA 72: National Fire Alarm Code© - 2019 ed.
NFPA196218	NFPA 1962: Standard for the Inspection, Care & Use of Fire Hose, Couplings, & Nozzles & the Service Testing of Fire Hose, 2018 ed.
NFPA1319	NFPA 13: Standard for Installation of Sprinkler Systems, 2019 ed.



NFPA1018



NFPA1717



NFPA17A17

EMERGENCY RESPONSE GUIDEBOOK to meet DOT 49CFR section 172.602 requirement. Any person transporting hazardous materials must carry one of these or all material safety data sheets pertaining to materials being transported in the vehicle. This pocket size version measuring 4" x 5½" is the handiest way to meet the requirement.

PART#	DESCRIPTION
ERGB	Emergency Guidebook



ERGB

FIRST AID SIGNS

3D Rigid Plastic

Rigid, tough plastic ($\frac{1}{32}$ " thick) with $\frac{1}{8}$ " diameter holes for easy perpendicular wall mounting. Screen printed with UV inks.

PART#	DESCRIPTION	W	H
PTD176	"Emergency Eye Wash...Keep Area Clear"	18"	10"
PTD261	"AED" Stand-Out Arrow	5"	6"
PTD262	"First Aid" Arrow	5"	6"



PTD176



PTD261



PTD262

Rigid Plastic

Rigid, tough plastic ($\frac{1}{32}$ " thick) mounts easily to the wall with predrilled mounting holes. Screen printed with UV inks.

PART#	DESCRIPTION	W	H
RP144A	"Emergency...First Aid Station"	8"	10"
RP176A	"Emergency...Eye Wash Keep Area Clear"	8"	10"



RP144A



RP176A

Vinyl Self Adhesive Signs

Self-Adhesive vinyl signs are silk screened with UV inks, then clear laminated for durability and fade resistance. Mounting surface must be clean, dry, smooth, and non-porous. To mount these on a porous surface, such as brick or concrete block, use our Sign On! Aerosol adhesive **P/N BA1**.

PART#	DESCRIPTION	W	H
BL144	"First Aid Station"	8"	12"
BL157	"First Aid Kit Inside"	4"	4"
BL170	"Fire Blanket" Arrow	4"	18"
G261	"AED" Label, Self Adhesive	6"	8"



BL144



BL157



BL170



G261

WATER-JEL TECHNOLOGIES EMERGENCY BURN CARE

WATER-JEL® FIRE BLANKETS & WRAPS are one-step systems for emergency first aid on a burn victim. They put out the fire, stop burn progression and cool the skin, relieve pain and protect the burn area from contamination. They consist of a scientifically formulated cooling gel and a special carrier. The 100% worsted wool material is soaked in a water-based/water-soluble, bacteriostatic and biodegradable gel. Can be placed directly over clothing and won't stick to burn injuries. They can be used to extinguish flames and smoldering clothes or dangerous **white phosphorous**. Available in foil pouch or easily identifiable plastic container with handle for convenient transport.

SHELF LIFE: 5 years from date of manufacture.

PART#	DESCRIPTION
C726004WJ	5' x 6' Fire Blanket in Canister



C726004WJ



P726004WJ

WATER-JEL® BURN DRESSINGS provide fast, one-step relief for emergency first aid when someone has been burned. The dressings stop burn progression and cool the skin, relieve pain and protect against airborne contamination. Burn Dressings are made with a scientifically formulated cooling gel and utilize a medical-grade nonwoven pad that is non-adherent, so they will not stick to burn injuries. **SHELF LIFE:** 5 years from date of manufacture.

The 12" x 16" Burn Dressing is used widely by EMS and firefighters. Large enough to protect the entire face, ears, neck and part of the head. With nose, mouth and eye slits and eyelid flaps.

PART#	DESCRIPTION
40460WJ	4" x 4" Burn Dressing
121620WJ	12" x 16" Burn Dressing (Face)



40460WJ



121620WJ

WATER-JEL® COOL JEL gels cool and soothe minor burns, dissipating the heat and protecting injuries from infection. Ideal for the workplace, this 25-pack dispenser box is well suited for larger kits and medicine chests, as well as first aid stations. No active ingredients. **SHELF LIFE:** 5 years from date of manufacture.

PART#	DESCRIPTION
CJ25600	Cool Jel 3.5 gm packet, Pkg 25



CJ25600

BLANKETS, LADDERS AND FIRE RETARDANT

FIRE BLANKETS AND CABINETS

Our 3-Ply Fiberglass Blanket comes in a red slim line cabinet complete with English/French instruction labels and pull straps for quick withdrawal. For smothering and extinguishing fires in Hospitals, Schools, Homes, and Kitchens. **ONE-TIME USE ONLY.**

- Made of 3 Ply Material – 2 Layers of Woven Glass Fiber, 1 Layer of Fire Retardant Film
- Independently tested – EN1869: 1997
- Red Slim Pack Thermoplastic Container
- Blanket size 72" (182 cm) x 48" (122 cm)
- Cabinet measures 16⁵/₈"H x 6¹/₄"W x 1¹/₂"D
- Pull straps for quick blanket withdrawal
- Bilingual Operating Instructions

PART#	DESCRIPTION
FB64	Fiberglass Fire Blanket and Cabinet



FB64

WOOL BLANKET and CABINET made of all steel construction. The wool blanket attaches to roller allowing a person to grab the attached arm loop and wrap themselves in the blanket in one continuous motion. The wool blanket measures 62" (203 cm) x 80" (157.5 cm) and is treated for fire retardancy. The steel cabinet measures 6¹/₂"W x 68"H x 4"D.

PART#	DESCRIPTION
FB1	Fire Blanket and Steel Cabinet Complete
2FB	Steel Fire Blanket Cabinet Only
FBR2	Wool Fire Blanket, Grey



FB1 / 2FB



FBR2

DROP DOWN SURFACE MOUNT CABINET features all steel construction complete with decal, surface mount, handy "drop" type, and includes inspection window cut out. Blanket (FBR2) sold separately. The wool blanket measures 62" (203 cm) x 80" (157.5 cm) and is treated for fire retardancy.

PART#	DESCRIPTION
DDFB1	Drop-Down Fire Blanket Cabinet
FBR2	Wool Fire Blanket, Grey



DDFB1



FBR2

FIRE BLANKETS AND CABINETS CONTINUED

WOOL BLANKET and VINYL BAG. The Vinyl Bag opens in one quick motion to gain access to the wool blanket. The vinyl bag measures 16"L x 12"W x 5½"D and features four mounting holes with brass grommets and hook-and-loop closure. The Wool Blanket measures 62" (203 cm) x 80" (157.5 cm) and is treated for fire retardancy.

PART#	DESCRIPTION
BFB	Fire Blanket and Bag Complete
BB1	Fire Blanket Vinyl Bag
FBR2	Wool Fire Blanket, Grey



BFB

ABS CABINET with WOOL BLANKET features a brass lock and screen-printed labeling. Cabinet is made of high-impact, flame-retardant ABS. The Blanket measures 62" (203 cm) x 80" (157.5 cm) and is treated for fire retardancy. No dangerous glass to break, rustproof, and theft-resistant. Red tub with clear cover.

PART#	DESCRIPTION
M2FBC	Fire Blanket and ABS Cabinet Complete
FBR2	Wool Fire Blanket, Grey
M12L	Brass Padlock Keyed Alike, 5/8" Shackle
M2C	Clear Mark II Replacement Cover



M2FBC



FBR2



M12L

EMERGENCY HOME FIRE ESCAPE LADDERS

Having an escape ladder available during an emergency situation can mean the difference between life and death.

- Extremely easy to deploy.
- Attaches quickly to window over 16" wide and less than 11" deep (from interior to exterior wall)
- Tangle-free design
- Extremely strong but lightweight
- Fully assembled, compact storage
- Ladder tested to 900 lbs"

PART#	DESCRIPTION
2D	13 ft Two-Storey Emergency Escape Ladder
3D	25 ft Three-Storey Emergency Escape Ladder



2D



2D / 3D

INSPECTA-SHIELD FIRE RETARDANT

Inspecta-Shield™ **FIRE RETARDANT** is a Class A fire retardant for fibers, lumber, and wood materials. Pre-mixed, easy to apply, non-toxic, non-allergenic, colorless, odorless (when dried), durable, and UV stable. UL classified and approved by the CA State Fire Marshal. Works by slowing horizontal and vertical flame spread. Does not prevent charring, but treated items will not support ignition. Directions are included. Not recommended for outdoor use.

NOTE: UL Letter of Certification can be granted up to two years after the date of manufacture.

PART#	DESCRIPTION
FRQS	One Quart Spray Fire Retardant
FRG	One Gallon Fire Retardant
FRP5	Five Gallon Fire Retardant



FRQS



FRG



FRP5

FIRE AXES

PICK HEAD FIRE AXE with a 6 lb. head and available with HICKORY or FIBERGLASS handle. Precision balanced for safe handling. Optional mounting bracket and hook available separately.

PART#	DESCRIPTION
406M	6 LB. Pick Head Fire Axe, 36" Hickory Handle
406Y	6 LB. Pick Head Fire Axe, 34" Yellow Fiberglass Handle
AB408	Axe Bracket and Hook
HHAN	Hickory Handle for 406 Axe
FBGLHAN	Fiberglass Handle for 406Y



TRAFFIC AND ROADSIDE SAFETY

REFLECTOR TRIANGLE KIT as required by FMCSR section 393.95. Consists of 3 triangles in a plastic storage box. Weighs 15 lbs. per kit, 4 per case.

PART#	DESCRIPTION
3TKD	3 Piece Reflective Triangle Kit



FORM HOLDER

FORM HOLDER or holding loose forms, invoices, work orders, etc. Swivel bar clip with a writing plate makes it easy to fill out invoices and other forms. Look professional and be organized using this heavy duty aluminum form holder.

PART#	DESCRIPTION
FH8512	Form Holder



EYE PROTECTION

Wearers of STORM® SAFETY GLASSES can expect extreme comfort with this face-flattering protective eyewear. Ratchet-action temples combined with non-slip rubber head grips create a customized fit for virtually any head size. Wraparound lens is constructed of lightweight, scratch-resistant polycarbonate. Meets ANSI Z87.1 requirements.

PART#	DESCRIPTION
EW107	Storm Safety Glasses, Clear Anti-Fog Lens
EW108	Black Frame with Grey Lens



BLACKJACK® SAFETY GLASSES in a sleek, style conscious design offer superb eye protection. Feature a wraparound, polycarbonate lens design with integral side shields and metal alloy temples with non-slip, rubber head grips. EW112 and EW113 both feature Duramass® AF4 anti-fog coating. Meets ANSI Z87.1 requirements.

PART#	DESCRIPTION
EW112	Blackjack Safety Glasses, Clear Anti-Fog Lens
EW113	Blackjack Safety Glasses, Gray Anti-Fog Lens
EW114	Blackjack Safety Glasses, Indoor/Outdoor Lens
EW115	Blackjack Safety Glasses, Silver Mirror Lens



These economical **SAFETY GOGGLES** feature a comfortable soft frame, direct ventilation and a wide, one piece, clear polycarbonate lens. Meets ANSI Z87.1 requirements.

PART#	DESCRIPTION
EW201	Economy Safety Goggles



EW201

Our premium **VERDICT® SAFETY GOGGLES** can be worn with most half-mask respirators while fitting over most prescription eyeglasses. Goggles feature a grey vinyl frame, clear anti-fog lens and adjustable elastic strap. Meets ANSI Z87.1 requirements.

PART#	DESCRIPTION
EW241	Verdict® Premium Safety Goggles



EW241

With **TACOMA® SAFETY GLASSES** you get low-cost protection without giving up quality, comfort, or durability. Made of strong, lightweight polycarbonate, with a one-piece wraparound lens for a wide field of vision and maximum protection. Meets ANSI Z87.1 requirements.

PART#	DESCRIPTION
EW101	Tacoma® Safety Glasses



EW101

TOMAHAWK® SAFETY GLASSES features a stylish wraparound design, fully adjustable temples and a one-piece polycarbonate lens with integral side shields. The lightweight frame provides added comfort and balance. Meets ANSI Z87.1 requirements.

PART#	DESCRIPTION
EW102	Tomahawk® Safety Glasses, Clear Lens



EW102

RESPIRATORY PROTECTION

Disposable **DUST MASKS** for relief from nuisance and non-toxic dusts, powders, and pollen. Lightweight, with adjustable elastic head strap and metal forming strip over nose for comfort.

NOTE: Does not provide NIOSH-approved respiratory protection.

PART#	DESCRIPTION
RP9500	Disposable Nuisance Dust Mask, Pkg/50



RP9500

Disposable **PARTICULATE RESPIRATORS** are maintenance free with soft, smooth inner lining and nose cushions for increased worker comfort. Custom shapes, nose pieces and head straps enable superior fit. Collapse resistant, double-shell construction for extended product life. NIOSH certified respirators have a 95% efficiency level.

PART#	DESCRIPTION
RP1730	N95 Particulate Respirator, Pkg/20



RP1730

HALF-MASK RESPIRATOR features lightweight elastomeric material, with cradle suspension and adjustable head straps. Includes Hygienic Form Guard to maintain respirator shape, cleanliness, proper fit and longer life. Comes in a reusable storage bag, ensuring compliance with OSHA storage requirements. Consult chemical MSDS for proper cartridge use. Mask and cartridges are NIOSH certified.

PART#	DESCRIPTION
RP9200	Half-Mask Respirator, Medium
RP9300	Half-Mask Respirator, Large
RPFR	Pre-Filter Retainer, Pkg/2
RPG01	Organic Vapor Cartridge, Pkg/2
RPG03	Organic Vapor, Acid Gas Cartridge, Chloride, Hydrogen Chlorine, Sulfur Dioxide, Pkg/2
RPG95N	Pre-Filter, Particulates Free of Oil (95% Efficiency), Pkg/10



RP9200

PLUNGER DISPENSING CANS

Justrite Plunger Cans

Dispense flammable liquids and solvents safely, without waste or exposure. Made of chemically resistant Ryton® and brass, the pump base is designed to leave less liquid in the bottom before having to refill.

Pushing down on the pump assembly fills the upper pan with liquid. Surplus liquid drains safely back into reservoir. The perforated upper pan serves as a flame arrester. Top rim has molded edge protector for smooth, trouble-free moistening.

PART#	DESCRIPTION	WGT LBS	LISTING	MATERIAL	COLOUR	H	DIA.
10108	Plunger Dispensing Can, 1 quart (1L), Steel	3	FM	STEEL	RED	6"	7¼"
10208	Plunger Dispensing Can, 2 quart (2L), Steel	3	FM	STEEL	RED	8"	7¼"
10308	Plunger Dispensing Can, 1 gallon (4L), Steel	4	FM	STEEL	RED	11"	7¼"



10108



10208



10308

CIGARETTE BUTT RECEPTACLES

Made of flame-retardant and sturdy polyethylene, this low maintenance smoker's friend won't rust, dent or crack. Innovative self-extinguishing design safely collects unsightly cigarette litter and reduces the risk of fire. Tie-down notches offer security and greater stability under severe weather conditions.

Units include a galvanized steel bucket that collects thousands of butts. For maximum cleaning convenience, use optional disposable bucket liners. Once bucket is full, simply twist-tie closed and throw away!

PART#	DESCRIPTION	WGT LBS	LISTING	MATERIAL	COLOUR	H	DIA.
26800P	Cigarette Butt Receptacle, Pewter Grey	12.5	FM	Polyethylene	Pewter Grey	38.5	16.5
26800BK	Cigarette Butt Receptacle, Deco Black	12.5	FM	Polyethylene	Deco Black	38.5	16.5
26800A	Cigarette Butt Receptacle, Adobe Beige	12.5	FM	Polyethylene	Adobe Beige	38.5	16.5
26800G	Cigarette Butt Receptacle, Green	12.5	FM	Polyethylene	Green	38.5	16.5



26800P



26800A



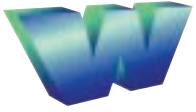
26800BK



26800G

STORAGE

SAFETY CABINETS FOR FLAMMABLES



THE WILLIAMS
BROTHERS
CORPORATION

Williams Brothers Cabinets for Flammables

The **WB SAFETY STORAGE CABINETS** will offer safer storing for flammable liquids, reduce time-consuming trips to remote storage rooms and permit storage close to work areas. Designed and labeled by the Underwriters Laboratories of Canada as meeting the requirements of the National Fire Code of Canada 1980 part 4 Flammable and Combustible Liquids performance clause 4.2.10.4. ULC Listed Flammable Liquid Safety Cabinets (Insulated).

ATTRIBUTE	SPECIFICATION	
Model No.	WB30	WB45
Material Specifications	Steel	Steel
Capacity	30 Gal (114 L)	45 Gal (170 L)
No. of Doors	2	2
Door Type	Manual	Manual
No. of Shelves	1	2
Adjustable Shelves	Yes	Yes
Dimensions, Exterior	44" W x 45" H x 19" D	44" W x 66" H x 19" D
Approvals	ULC	ULC
Weight (lbs)	350	430

Accessories:

PART#	DESCRIPTION
SH1A	Extra Metal Shelf for WB30, 45 Gal Cabinets
VENTCAP	2" Vent Cap



WB30



WB45





Justrite Classic Safety Cabinets for Flammables

Protect workers, reduce fire risks, and improve productivity by storing flammable fuels and chemicals in code-compliant safety cabinets. Designed to meet OSHA and NFPA standards, Sure-Grip® EX cabinets are constructed of sturdy 18-gauge (1-mm) thick double-wall, welded steel with 1½” (38-mm) of insulating air space for fire resistance. High-performance, self-latching doors close easily and securely for maximum protection under fire conditions. Fail-safe closing mechanism ensures three-point stainless steel bullet latching system works every time.

Manual-close door(s) opens to a full 180 degrees and self-latches when pushed closed. Self-close door(s) shuts and latches automatically when a fusible link melts at 165°F (74°C) under fire conditions.

- Manual Close or Self Close Door Option
- Patented SpillSlope galvanized steel shelves
- Dual vents with flame arresters
- Four adjustable self-leveling feet
- Grounding connector
- Ten-year warranty

ATTRIBUTE	SPECIFICATION		
Model No.	893000	893020	893300
Material Specifications	18 Ga CR Steel	18 Ga CR Steel	18 Ga CR Steel
Capacity	30 Gal (114 L)	30 Gal (114 L)	30 Gal (114 L)
No. of Doors	2	2	2
Door Type	Manual	Self Close	Manual
No. of Shelves	1	1	1
Adjustable Shelves	Yes	Yes	Yes
Dimensions, Exterior	43” W x 44” H x 18” D	43” W x 44” H x 18” D	36” W x 35” H x 24” D
Dimensions, Interior	39.5” W x 39.625” H x 14.562” D	39.5” W x 39.625” H x 14.562” D	32.625” W x 30.625” H x 21.75” D
Approvals	FM	FM	FM
Compliance	NFPA, OSHA	NFPA, OSHA, IFC	NFPA, OSHA
Weight (lbs)	231	237	210



893000



893300



893020

ATTRIBUTE	SPECIFICATION			
Model No.	894500	894520	896000	896020
Material Specifications	18 Ga CR Steel	18 Ga CR Steel	18 Ga CR Steel	18 Ga CR Steel
Capacity	45 Gal (170 L)	45 Gal (170 L)	60 Gal (227 L)	60 Gal (227 L)
No. of Doors	2	2	2	2
Door Type	Manual	Self Close	Manual	Self Close
No. of Shelves	2	2	2	2
Adjustable Shelves	Yes	Yes	Yes	Yes
Dimensions, Exterior	43” W x 65” H x 18” D	43” W x 65” H x 18” D	34” W x 65” H x 34” D	34” W x 65” H x 34” D
Dimensions, Interior	39.5” W x 60.5” H x 14.562” D	39.5” W x 60.5” H x 14.562” D	30.75” W x 60.5” H x 30.34” D	30.75” W x 60.5” H x 30.34” D
Approvals	FM	FM	FM	FM
Compliance	NFPA, OSHA	NFPA, OSHA, IFC	NFPA, OSHA	NFPA, OSHA, IFC
Weight (lbs)	310	313	387	392



894500



894520



896000



896020

We are in the business of growing your business

COMPACT AND COUNTERTOP CABINETS FOR FLAMMABLES

Justrite COMPAC Safety Cabinets

COMPAC SAFETY CABINETS fit almost anywhere and provide protection even where space is at a premium. These cabinets are ideal when storing lesser quantities of flammable liquids at a workstation or adding to existing storage capacities. These cabinets have all the great features and benefits of the Justrite Classic cabinets.

The door(s) of the Self-close Models shuts and latches automatically when a fusible link melts at 165°F (74°C) under fire conditions.

- 18-gauge (1-mm) thick double-wall construction
- Manual or Self Close Door Models Available
- Meet OSHA and NFPA standards
- FM Approved
- Patented SpillSlope galvanized steel shelves
- Dual vents with flame arresters
- Four adjustable self-leveling feet
- Grounding connector
- 10 Year Warranty

ATTRIBUTE	SPECIFICATION		
Model No.	891200	891220	891500
Material Specifications	18 Ga CR Steel	18 Ga CR Steel	18 Ga CR Steel
Capacity	12 Gal (45 L)	12 Gal (45 L)	15 Gal (57 L)
No. of Doors	1	1	1
Door Type	Manual	Self Close	Manual
No. of Shelves	1	1	1
Adjustable Shelves	Yes	Yes	Yes
Dimensions, Exterior	23.25" W x 35" H x 18" D	23.25" W x 35" H x 18" D	23.25" W x 44" H x 18" D
Dimensions, Interior	20" W x 30.5" H x 14.562" D	20" W x 30.5" H x 14.562" D	20" W x 39.625" H x 14.562" D
Approvals	FM	FM	FM
Compliance	NFPA, OSHA	NFPA, OSHA	NFPA, OSHA
Weight (lbs)	129	118	154



891220



891200



891500

Justrite Countertop Cabinets for Flammables

COUNTERTOP SAFETY CABINETS allow increased access to frequently used liquids, without compromising safety. Portable size keeps work areas flexible. Use optional wall hanger assembly for wall mounting. These cabinets have all the features and benefits of Justrite's larger (30-90 Gal) Classic Safety Cabinets for flammables, but fit almost anywhere where floor space is limited.

- 18-gauge (1-mm) thick double-wall construction Doors
- Manual Close
- Meet OSHA and NFPA standards
- Patented SpillSlope galvanized steel shelves
- Dual vents with flame arresters
- Four adjustable self-leveling feet
- Grounding connector
- Trilingual warning label
- 10 Year Warranty

ATTRIBUTE	SPECIFICATION
Model No.	890400
Material Specifications	18 Ga CR Steel
Capacity	4 Gal (15 L)
No. of Doors	1
Door Type	Manual
No. of Shelves	1
Adjustable Shelves	Yes
Dimensions, Exterior	17" W x 22" H x 17" D
Dimensions, Interior	13.75" W x 18.5" H x 13.75" D
Compliance	NFPA, OSHA
Weight (lbs)	72



890400

SDS DOCUMENT STORAGE

STORAGE BOX is impervious to dirt and moisture. This handy storage unit is tough, boasting rustproof polyethylene construction. There's also heavy-duty, double-sided tape for easy installation just about anywhere and a bright-red finish so you won't lose it. Unit features a flip top with easy snap latches for instant access. Storage box measures 10¼" x 12½" x 2¼" (outside) and 8¾" x 11½" x 1¾" (inside).

PART#	DESCRIPTION
23303	Document Storage Box
23310	(1) MSDS Label & (2) Blank Labels



23303

DISPOSAL

Rags and cloths soaked with solvents, thinners, linseed oil, combustible adhesives and other flammable liquids present a serious fire risk when improperly discarded. Lid opens to no more than 60 degrees and stays closed when not in use, isolating contents from fire sources and limiting oxygen to virtually eliminate the risk of spontaneous combustion. Round construction and elevated base allow circulation of air around can to disperse heat and reduce moisture build-up and rusting. Durable steel construction with a powder-coat finish provides chemical resistance.

PART#	DESCRIPTION	LISTING	STYLE	HEIGHT	DIA.	CAPACITY
9100	Can, OWC W/Foot Cover, 6G, Red	FM, UL, OSHA	Foot Operated, Self-Close	15⅞"	11⅞"	6 Gal (20L)
9300	Can, OWC W/Foot Cover, 10G, Red	FM, UL, OSHA	Foot Operated, Self-Close	18.25"	13.937"	10 Gal (34L)
9500	Can, OWC W/Foot Cover, 14G, Red	FM, UL, OSHA	Foot Operated, Self-Close	20.25"	16⅙"	14 Gal (52L)
9700	Can, OWC W/Foot Cover, 21G, Red	FM, UL, OSHA	Foot Operated, Self-Close	23⅞"	18⅞"	21 Gal (80L)
9110	Can, OWC w/Hand Cover, 6G, Red	FM, UL, OSHA	Hand Operated	15⅞"	11⅞"	6 Gal (20L)
9310	Can, OWC w/Hand Cover, 10G, Red	FM, UL, OSHA	Hand Operated	18.25"	13.937"	10 Gal (34L)
9710	Can, OWC w/Hand Cover, 21G, Red	FM, UL, OSHA	Hand Operated	23⅞"	18⅞"	21 Gal (80L)



09100

09500

09300

09310

09700

09110

09710

TRANSFER

TYPE I SAFETY CANS

TYPE 1 SAFETY CANS are for carrying flammable liquids. Features terne plate (lead/tin coated steel) construction to protect cans against abrasion and rough use. Justrite's® state-of-the-art powder coat paint finish resists solvents, acids and alkalis and minimizes effects of corrosion and humidity. Comes with free-flow flame arrester and a positive spring-mounted relief mechanism that automatically vents at 5 psi. FM, UL and ULC approved.

PART#	DESCRIPTION	WEIGHT	LISTING	COMPLIANCE	HEIGHT	DIA.	CAPACITY
7110100	1 Gal. Type 1, Red	4	FM, ULC	NFPA, OSHA	11"	9½"	1 Gal (3.79L)
7120100	2 Gal. Type 1, Red	6	FM, ULC	NFPA, OSHA	13¾"	9½"	2 Gal (7.5L)
7125100	2½ Gal. Type 1, Red	6	FM, ULC	NFPA, OSHA	11½"	11¾"	2½ Gal (9.47L)
7150100	5 Gal. Type 1, Red	8	FM, ULC	NFPA, OSHA	16⅞"	11¾"	5 Gal (19L)
11202Y	Poly Funnel for Type 1 Can Slip on for Terne Cans Only				¾" x 11"		



7110100

7120100

7125100

11202Y

7150100

We are in the business of growing your business

TYPE II SAFETY CANS

TYPE II SAFETY CANS are for carrying flammable liquids. Leak-proof terne plate (lead/tin coated steel) construction with powder coat finish to resist solvents, acids, and alkalis. Features a built-in flexible metal hose for spill-free pouring, swinging handle design for easy handling, free-flow flame arrester to stop flashback ignition and a relief mechanism that vents pressure at 5 psi. FM, UL and ULC approved.

PART#	DESCRIPTION	WEIGHT	LISTING	COMPLIANCE	HEIGHT	DAI.	CAPACITY
7210120	1 Gal Type II, 5/8" x 9" Hose	7	FM, ULC	NFPA, OSHA	10½"	9½"	1 Gal (3.79L)
7220120	2 Gal Type II, 5/8" x 9" Hose	8	FM, ULC	NFPA, OSHA	10½"	9½"	2 Gal (7.5L)
7250130	5 Gal Type II, 1" x 12" Hose	10	FM, ULC	NFPA, OSHA	17½"	11¾"	5 Gal (19L)
7250120	5 Gal Type II, 5/8" x 9" Hose	10	FM, ULC	NFPA, OSHA	17½"	11¾"	5 Gal (19L)
11089	1" x 9" Flexhose						



PROTECTIVE CLOTHING

TYVEK® PROTECTIVE COVERALLS with serged seams, front zipper and collar. The most popular disposable protective clothing available.

PART#	DESCRIPTION
555L	Coverall, White, LG
555XXL	Coverall, White, 2XL
TYBC	Boot Cover, Non-Skid, Gray, Universal



TYVEK® COVERALLS



LOW COST 360° REFLECTIVE SAFETY VEST with the following features: 360° reflective, 5 point "Tear-Away". One size fits all. Hook and loop side straps have 2" reflective strip. Made of light-weight knitted polyester. Fluorescent orange with black nylon edging. One Size Adult.

PART#	DESCRIPTION
SV360	360° Reflective Safety Vest, One Size Adult



SV360

SV360 Back

- **FIRE ALARM PRODUCTS**



CONVENTIONAL FIRE ALARM PANELS

2 TO 6 ZONE CONTROL PANELS

Secutron 2600

PART#	DESCRIPTION
MR2602R	FACP, 2 Zone, Red
MR2605R	FACP, 5 Zone, Red



MR2602R



MR2605R



NEW Mircom FA-100

PART#	DESCRIPTION
FA-103	Fire Alarm Panel, 3 zone, White door, *Red available by special order 4-6 weeks leadtime
FA-106	Fire Alarm Panel, 6 zone
FA-106R	Fire Alarm Panel, 6 zone, Red door
FA-102TR	Flush Trim Ring
RTI1	Remote Trouble Indicator

NEW



FA-103/FA-106

NEW Kidde FX Conv.

PART#	DESCRIPTION
FX-5R	FACP, 5 Zone
FX-5RD	FACP, 5 Zone with DACT/Modem
FX-5RF	FACP, 5 Zone, French Canada

NEW



FX-5

8 TO 72 ZONE CONTROL PANEL

Mircom FA-1000

PART#	DESCRIPTION
FA1008KADS	8 Zone Starter Kit includes: MCC-1024-6 Chassis c/w, 4 Indicator Circuits, 8 Initiating Circuits 6 Amp Power Supply, Expandable to 24 Class B or 12 Class A, Multiplexed Annunciator Port Includes UB-1024DS Backbox & DOX-1024DS White Door Expansion Modules: DM1008A - 8 Initiating Ccts / SGM1004A - 4 Indicating Ccts / RM1008A - 8 Auxiliary Relays Central Station Tie Modules: PR300 Polarity Reversal & City Tie Module / UDACT-300A Zoned Digital Communicator Module NOTES: A) FA-1008KADS Kits Support 2 Expansion Modules & 1 Central Station Module B) Initiating Ccts can be Configured for Class B or Class A (Class A uses 2 Class B Ccts) C) Indicating Ccts can be wired Class A or Class B D) Order Batteries Separately
MCC-1024-6ADS	FA-1000 Series Main Chassis, DIP SWITCH DISCONNECT, c/w 8 Class B (Style B) Initiating Ccts 4 Class A/B (Style Z/Y) Indicating Ccts (1.7 Amp), Common Al., Suprv. & Tr. Contacts (28 VDC @ 1 Amp) 24 Bi-Colored Display Points, 6 Amp Power Supply, Multiplexed Annunciator, Supports 3 Adder Modules Mounts in UB-1024DS Backbox (Ordered Separately), Requires DOX-1024DS White Door (Ordered Separately)
MCC-1024-12ADS	Series 1000 Main Chassis, DIP SWITCH DISCONNECT, c/w 8 Class B (Style B) Initiating Ccts 4 Class A/B (Style Z/Y) Indicating Ccts (1.7 Amp), Common Al., Suprv. & Tr. Contacts (28 VDC @ 1 Amp) 24 Bi-Colored Display Points, 12 Amp Power Supply, Multiplexed Annunciator, Supports 3 Adder Module Mounts in UD-1024DS Backbox (Ordered Separately), Requires DOX-1024DS White Door (Ordered Separately)
MCC-1024-12XTDS	FA-1000 Series Main Chassis, DIP SWITCH DISCONNECT, c/w 8 Class B (Style B) Initiating Ccts 4 Class A/B (Style Z/Y) Indicating Ccts (1.7 Amp), Common Al., Suprv. & Tr. Contacts (28 VDC @ 1 Amp) 72 Bi-Colored Display Points, 12 Amp Power Supply, Supports 8 Adder Modules & One PR-300 or One UDACT-300A Mounts in a BBX-1024XT Enclosure (Ordered Separately)



FA1008KADS



MCC-1024-12XTDS

8 TO 72 ZONE CONTROL PANEL CONTINUED

NEW *Kidde FX Conv.*

PART#	DESCRIPTION
▶ FX-10R	FACP, 10 Zone, Red – 10 Class B IDCs and 4 Class B NACs, 7.0A NAC power, (Pairs of IDCs and NACs convertible to single Class A circuits), 120VAC power source, 24VDC output
▶ FX-10RD	FACP, 10 Zone with DACT/Modem
▶ FX-10RF	FACP, 10 Zone, French Canada



FX-10

ENCLOSURES

Mircom FA-1000

PART#	DESCRIPTION
DOX-1024DS	Universal Door for UB-1024DS Backbox, White
DOX-1024DR	Universal Door for UB-1024DS Backbox, Red
UB-1024DS	Universal Backbox for Compact Main Control Units, Black
BBX-1024XT	Backbox Enclosure for XT(DS) Main Control Units c/w Removable Door, Cat-30 Lock & Key Holds one XT Style Main Chassis & up to 17 A/H Battery White Door & Black Backbox



Kidde FX Conv.

PART#	DESCRIPTION
MFC-A	Multi-function Cabinet (fire alarm accessory enclosure)
F-TRIM35R	Semi Flush Trim Kit for 5 zone enclosures, Red
F-TRIM10R	Semi Flush Trim Kit for 10 zone enclosures, Red

ADDER MODULES

Mircom FA-1000 Series

PART#	DESCRIPTION
DM1008A	8 Class B (Style B) or 4 Class A (Style D) Initiating Ccts. Bi-Coloured, Alarm/Supervisory, LED, Zoned Trouble LED, Uses one Module Space
SGM1004A	4 Class A/B (Style Z/Y) Indicating/Notification Appliance Circuit (NAC) Module, Ccts. Rated @ 1.7 Amps Remote Signal Silence Input per Signal card, Uses One Module Space
RM1008A	8 Auxiliary Programmable Relays, Form 'C' Contact Rated for 28 VDC @ 1 Amp, Uses One Module Space



RM1008A

Kidde FX Conv.

PART#	DESCRIPTION
FSRRM24	Remote Relay Module – Five Form C relays. Configurable for IDCs 1-5, or 6-10, or common system indications or matrix mode. Requires MFC-A or other listed fire alarm enclosure.
FSRRM-S11	11" Mounting track, Holds up to two FSRRM24s
F-XTR120	Expander Transformer, 120 Vac - For FX-10 only

FIRE ALARM REMOTE MOUNT AUX. RELAY

PART#	DESCRIPTION
RM-1001	Fire Alarm Auxiliary Relay 24 VDC, For Use On A Supervised Fire Alarm Signal Circuit

END OF LINE RESISTOR PLATES

PART#	DESCRIPTION
MP300W	Mircom EOL Resistor Plate - White (one per zone) 3.9K ½ Watt
MP-300S	Mircom EOL Resistor Plate - Stainless Steel Finish (one per zone) 3.9K ½ Watt
EOL-P1	Kidde EOL Resistor Kit includes 7 EOL resistors including 4.7K, 3.6K and 1.1K resistors



MP300W

MIR-65 SERIES SMOKE DETECTOR KITS

PART#	DESCRIPTION
NEW MPD-65PK	MIR-65 Series Photoelectric Detector Kit c/w Photoelectric Detector Head and 2-Wire E-Z Fit Base

INTELLIGENT FIRE ALARM CONTROL PANELS

INTELLIGENT CONTROL PANELS

NEW Mircom FX-350

PART#	DESCRIPTION
▶ FX-351-LW	Intelligent Fire Alarm Control Panel, c/w Two Line LCD Display, 1 Addressable Analog Loop (126 Devices) 4 Indicating Circuits (1.7 Amps) Class B (Style Y), 2 Line UDACT Digital Communicator & Modem Supports Multiplexed LCD & LED Remote Annunciation, Alarm & Event Logs 5 Amp Power Supply (Signal & Aux Supply), Configurable Via Front Panel, Laptop or Remote Dial Up Provision to expand to 378 points (Requires ALC-252), Provision to add two RAX-332 Red Door and Black Enclosure
▶ FX-351-LDW	Intelligent Fire Alarm Control Panel, 126 Devices, 32 Zone
▶ FX-353-LDW	Intelligent Fire Alarm Control Panel, c/w Two Line LCD Display, 3 Addressable Analog Loops (378 Devices) 32 Zone Alarm & Trouble LED Configurable Annunciator, Expandable 64 Zones 4 Indicating Circuits (1.7 Amps) Class B (Style Y) Supports Multiplexed LCD & LED Remote Annunciation, Alarm & Event Logs 5 Amp Power Supply (Signal & Aux Supply), Configurable Via Front Panel, Laptop or Remote Dial Up White Door and Black Enclosure
▶ ALC-252	Two Loop Adder Module (252 devices)
▶ RAX-332	Adder Annunciator Module c/w 32 Bi-Coloured Alarm/Supervisory LEDs & 32 Zoned Trouble LEDs

**NEW**

FX-351-LDW

NEW

RAX-332

NOTES:

- The FX-351/FX-353 systems will support the following items (ordered separately):
 - up to a RS1212 Battery (12 Amp Hr)
 - class A converters OCAC-304
 - additional relays RM-312 (12) or RM-306 (6)
 - PR-300 module city tie & polarity reversal module
 - a combination of seven (7) remote multiplexed LED annunciators, LCD annunciators & smart relays
- The FX-351/FX-353 systems can be configured via the front panel switches, or with the use of a laptop computer (requires UIMA configuration tool). To remote program or retrieve the alarm(200) or event(200) logs the panel must include a UDACT.
- The RAM-300LCDW remote LCD annunciator is only ULC listed as an ancillary remote annunciator and can not be used as a primary annunciator.
- The FX-351/FX-353 will charge up to a 26 Amp Hr battery which will require a remote mount battery cabinet (BC-160)
- The FX-351/FX-353 include one 32 point internal annunciator. One additional RAX-332 internal annunciator module can be added to increase the internal annunciator points to 64.
- Order End of Line Plates MP-300 Separately (one per signal circuit)

INTELLIGENT CONTROL PANELS CONTINUED

NEW *Kidde FX Intell.*

PART#	DESCRIPTION
▶ FX-64R	One loop system with 64-point capacity, Two NACs, Red Door, Surface Mount Enclosure, Order Dialer Separately
▶ FX-64RD	One loop system with 64-points capacity, Includes a Two-Line Dialer, Two NACs, Red Door, Surface Mount Enclosure
▶ FX-64RF	One loop system with 64-point capacity, Two NACs, Red Door, Surface Mount Enclosure, 110V, French Canada
▶ FX-1000-CA	Four loop system with one 250-point loop installed, 1,000 point capacity max, Four NACs, Red Door, Surface Mount Enclosure, 110V, Canada (order dialler separately)
▶ FX-1000D	Four loop system with one 250-point loop installed, 1,000 point capacity max, Includes a Two-Line Dialer, Four NACs, Red Door, Surface Mount Enclosure
▶ FX-1000F	Four loop system with one 250-point loop installed, 1,000 point capacity max, Four NACs, Red Door, Surface Mount Enclosure, 110V, French Canada



FX Series Intelligent

ENCLOSURES

Kidde FX Intell.

PART#	DESCRIPTION
SA-TRIM1	Semi-Flush Mount, Trim Kit, FX-64, Black
SA-TRIM2	Semi-Flush Mount, Trim Kit, FX-1000, Black

OPTIONAL MODULES

Mircom FX-350

PART#	DESCRIPTION
PR300	Polarity Reversal & City Tie. c/w Alarm, Supervisory & Trouble Transmit Capabilities
OCAC-304	Series 300 Output Class 'A' Converter Module 4 Circuits



Kidde FX Intell.




PART#	DESCRIPTION
SA-232	RS232 Serial Interface Module, 4 terminal connections for supervised/unsupervised printers and connection to PC's, mounts in cabinet
SA-CLA	Class A NAC module, for 64pt systems only, mounts to main board in cabinet
SA-DACT	Upload/Download Dialer/Modem, Dual-Line, RJ31, mounts to base plate in cabinet
SA-ETH	Ethernet Programming/Diagnostics Interface, RJ45, mounts to base plate in cabinet
FX-SLC1	Expansion module, one 250-device loop
FX-SLC2	Expansion module, two 250-device loops, 500 devices total
D16L-FA	Remote Annunciator Module, LED, 16-Zone, 2-LED'S per Zone
RZI16-2RS	Remote Zone Interface Module, rotary switch addressing, Sixteen Class B Initiating Device Circuits and two Class B Supervised Output Circuits Mounting bracket included



REMOTE TROUBLE UNIT

PART#	DESCRIPTION
RTI1	Remote Trouble Indicator

POWER SUPPLIES

PART#	DESCRIPTION
 BPS-1100	Mircom Booster Power Supply, 120VAC Input 24VDC 11Amps Max Unregulated Output 3 Supervised Programmable Contact Inputs, 4 Style Y/Z (Class A/B) Indicating Circuits (1.7Amps) Indicating Circuits Expandable to 12 (2 SGM-1004A), Supports Supervised or Unsupervised Suite Isolators Regulated Auxiliary 24VDC 1.7 AMP Output, Trouble Output Contacts, Space for 6 to 17 Amp Hr Battery
 BPS6AC	Kidde 6.5 Amp Booster Power Supply 4 Class B 3-Amp alarm output ccts - configurable as aux ccts ,Configurable for either 4 Class-B or 2 Class-A ccts. Supports 2 x 12V13Ah or 12V7.2Ah batteries, Configurable signal rates, Field selectable input-to-output correlation Two inputs allow activation from existing NACs, One dedicated 200mA auxiliary output Built-in Genesis horn and strobe synchronization Note: An EOL-P1 is required for each Class B Alarm output cct connected to the BPS
 BPS10AC	Kidde 10 Amp Booster Power Supply 4 Class B 3-Amp alarm output ccts - configurable as aux ccts, Configurable for either 4 Class-B or 2 Class-A ccts. Supports 2 x 12V13Ah or 12V7.2Ah batteries, Configurable signal rates, Field selectable input-to-output correlation Two inputs allow activation from existing NACs, One dedicated 200mA auxiliary output Built-in Genesis horn and strobe synchronization Note: An EOL-P1 is required for each Class B Alarm output cct connected to the BPS
EOL-P1	Kidde EOL Resistor Kit includes 7 EOL resistors including 4.7K, 3.6K and 1.1K resistors



NEW BPS-1100



BPS6AC / 10AC

 **Mircom**

RELEASING PANEL

Mircom FR-320 Series

PART#	DESCRIPTION
FR320R	Releasing Panel c/w 6 Initiating Class B (Style B) c/w By-passing Switches 6 Bi-coloured Alarm LEDs & 6 Amber Trouble LEDs 4 Indicating Circuits (1.7 Amps) Class B (Style Y) c/w By-passing Switches Supports Deluge, Pre Action or Releasing Functions Supports Multiplexed Annunciation & Smart Relays Eleven (11) Pre Configured Modes, Alarm & Event Logs 5 Amp Power Supply (Signal & Aux Supply), Front Panel Configurative Red Door and Black Enclosure
FR320W	Releasing Panel c/w 6 Initiating Class B (Style B) c/w By-passing Switches 6 Bi-coloured Alarm LEDs & 6 Amber Trouble LEDs 4 Indicating Circuits (1.7 Amps) Class B (Style Y) c/w By-passing Switches Supports Deluge, Pre Action or Releasing Functions Supports Multiplexed Annunciation & Smart Relays Eleven (11) Pre Configured Modes, Alarm & Event Logs 5 Amp Power Supply (Signal & Aux Supply), Front Panel Configurative White Door and Black Enclosure



FR320R

NOTES:

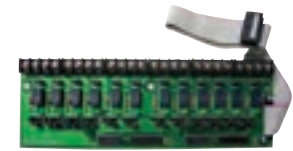
- The FR-320 releasing system will support the following items (ordered separately):
 - up to a RS1212 (12 Amp Hr)
 - class A converters ICAC-306, OCAC-302
 - additional relays RM-312 (12) or RM-306 (6)
 - PR-300 module city tie & polarity reversal module
 - a combination of four (4) remote multiplexed LED annunciators & smart relays. The FR-320 does NOT support the RAM-300LCDW Series 300 LCD Annunciator.
- The Series 300 system is configured via the front panel switches with out the need of a laptop computer. Use CFG-300 to retrieve the alarm (200) or event (200) logs the panel remotely the FR-320 must include a UDACT
- The FR-320 will support all of the Mircom LED type annunciators
- The FR-320 will charge up to a 26 Amp Hr Battery which requires a remote battery cabinet (BC-160)

OPTIONAL MODULES



Mircom FR-320 Series

PART#	DESCRIPTION
RM306	Series 300 6 Relay Adder c/w 6 Relays Rated 28 VDC @ 1 Amp (NO or NC) Configurable for One to One Common Alarm or Common Supervisory
RM312	Series 300 12 Relay Adder c/w 12 Relays Rated 28 VDC @ 1 Amp (NO or NC) Configurable for One to One Common Alarm or Common Supervisory
PR300	Polarity Reversal & City Tie c/w Alarm, Supervisory & Trouble Transmit Capabilities
ICAC306	Series 300 Input Class 'A' Converter Module 6 Circuits (For Use With FA-300 or FA-301 Panels)
MP320W	Solenoid End of Line Resistor, White
MP1500W	Current Limiter Module, White



RM306 / RM312

SMART RELAY



Mircom FR-320 Series

PART#	DESCRIPTION
SRM-312W	Series 300 Smart Relay Module, c/w White Enclosure 12 Configurable Relays (NO or NC), One to One, Common Alarm, Common Supervisory



SRM-312W

ABORT STATION

PART#	DESCRIPTION
SS2004ZA-EN	Momentary mushroom switch abort station, stainless steel backplate N.O. or N.C. SPST gold plated contact blocks rated for 3 amps @ 600 VAC or 1 amp @ 250 VDC 1st line of top label reads :“EXTINGUISHING SYSTEM”; 2nd line of top label reads: “ABORT STATION”; Bottom label reads “PUSH AND HOLD TO CANCEL”



SS2004ZA-EN

ANNUNCIATORS

GRAPHIC ANNUNCIATION MODULES

NEW FX-350, FA-1000

PART#	DESCRIPTION
▶ MGD-32	Master Graphic Driver Board c/w, Fire Alarm Common Control Switch Inputs & LED Outputs 32 Supervised Outputs, Output Connections via Terminals or Ribbon Cable Mounts in Graphic Wallbox or BB-5008 or BB-5014 Enclosures
▶ AGD-048	Adder Graphic Driver Board, c/w 48 Supervised Outputs, Output Connections via Terminals or Ribbon Cable Mounts in Graphic Wallbox or BB-5008 or BB-5014 Enclosures

REMOTE ANNUNCIATION NOTES:

- 1) The maximum number of remote annunciators the FX-2000/FA-1000 can support is 8 without the use of a remote shared display
- 2) Each remote annunciator must have a master i.e. RAM-1032TZDS or MGD-32
- 3) All of these annunciators must be configured the same in each location
- 4) The total number of LED or graphic type of annunciators can not exceed 8
- 5) Graphic and LED type annunciators can be inter mixed on the same RS-485 output
- 6) Consult the factory for power supply requirements for large systems
- 7) Graphic annunciators will require an external lamp test power supply
- 8) Graphic annunciator driving incandescent lamps will require an external supervised power supply consult the factory
- 9) For reduced zone annunciation see remote shared display

ANNUNCIATORS

NEW RA-200

PART#	DESCRIPTION
▶ RAM-208R	Remote Multiplex Annunciator c/w, 8 Bi-Coloured LEDs Common Control Features: Signal Silence, Buzzer Silence, System Reset, Lamp Test Indicators -- A.C. On, Common Trouble & Signal. Silence Mounts in 4 Gang Electrical Box, Red Finish Used with Series 300 and Series 1000
▶ RAM-208	Remote Multiplex Annunciator c/w, 8 Bi-Coloured LEDs Common Control Features: Signal Silence, Buzzer Silence, System Reset, Lamp Test Indicators -- A.C. On, Common Trouble & Signal. Silence Mounts in 4 Gang Electrical Box, White Finish Used with Series 300 and Series 1000
▶ RAM-216	Remote Multiplex Annunciator c/w, 16 Bi-Coloured LEDs Common Control Features: Signal Silence, Buzzer Silence, System Reset, Lamp Test Indicators -- A.C. On, Common Trouble & Signal. Silence Mounts in 4 Gang Electrical Box, White Finish Used with Series 300 and Series 1000

NEW



RAM-208

RA-1000

PART#	DESCRIPTION
RAM1016TZDS	Main Annunciator Chassis c/w 16 Bi-Coloured Alarm/ Supervisory LEDs & 16 Zoned Trouble LEDs Common Indicators -- AC On, Common Trouble, Auxiliary Disconnect, 2 Stage Acknowledge & General Alarm Activate (if Config.), Common Controls -- Reset, Lamp Test, Fire Drill, Auxiliary Disconnect, Local Buzzer & Signal Silence Mounts in BB-1000 Series enclosure or BB-5008 or BB-5014
RAM1032TZDS	Main Annunciator Chassis c/w 32 Bi-Coloured LEDs, 32 Zoned Trouble LEDs Common Indicators -- AC On, Common Trouble, Auxiliary Disconnect, 2 Stage Acknowledge & General Alarm Activate (if Config.), Common Controls -- Reset, Lamp Test, Fire Drill, Auxiliary Disconnect, Local Buzzer & Signal Silence Mounts in BB-1000 Series enclosure or BB-5008 or BB-5014
RAX-1048TZDS	Adder Annunciator Chassis c/w 48 Bi-Coloured LEDs; 48 Zoned Trouble LEDs Mounts in BB-1000 Series enclosure or BB-5008 or BB-5014



RAM1016TZDS



RAM1032TZDS

RA-300

PART#	DESCRIPTION
RAM-300LCDW	Remote LCD Annunciator c/w White Semi Flush Enclosure

NEW Kidde FX Conv.

PART#	DESCRIPTION
▶ FRSI	Remote Zone Annunciator, LED, Alarm, Trouble, Supv, Ground Fault
▶ FSRZI-A	Remote Zone Annunciator, LED, Alarm by Zone
▶ FSRZI-SA	Remote Zone Annunciator, contains 5 bi-color LED's (Red/Yellow) for alarm or supervisory zone indication, jumper selectable zone settings, single gang, includes white trim plate
▶ FSAT2	Remote Annunciator Wall Trim Plate, Two Gang, White
▶ FSAT3	Remote Annunciator Wall Trim Plate, Three Gang, White
▶ FSAT4	Remote Annunciator Wall Trim Plate, Four Gang, White
▶ K-FSRA10	10-zone remote annunciator with system status LEDs (English overlay)
▶ K-FSRA10F	Single Unit 10 zone remote annunciator for FX-10, French Canada
▶ K-FSRA10C	10-zone remote annunciator with system status LEDs and common controls (English overlay)
▶ K-FSRA10CF	Single Unit 10 zone remote annunciator for FX-10 (with common controls), French Canada

NEW



K-FSRA10C

NOTES:

The FRSI can be installed alone or with one or more FSRZI-As. The FRSI and FSRZI-A require trim plates (sold separately). Each panel will support two FRSIs.

ANNUNCIATORS CONTINUED

NEW *Kidde FX Intell.*

PART#	DESCRIPTION
▶ K-RLCD	LCD text annunciator without common controls, English, Most Popular
▶ K-RLCD-C	LCD text annunciator with common controls, English, Most Popular
▶ K-RLCD-CF	LCD text annunciator with common controls, French
▶ K-RLCD-CR	LCD text annunciator with common controls, English, Red
▶ K-RLCDF	LCD text annunciator without common controls, French
▶ K-RLCD-R	LCD text annunciator without common controls, English, Red
▶ K-RLED24	24-pair LED zone expander with expander cable and zone card insert
▶ K-RLED24R	24-pair LED zone expander with expander cable and zone card insert, Red
▶ K-RLED-C	16-pair LED zone annunciator with common controls, English
▶ K-RLED-CF	16-pair LED zone annunciator with common controls, French
▶ K-RLED-CR	16-pair LED zone annunciator with common controls, English, Red
▶ RA-ENC1	Single unit remote annunciator enclosure, 4" box mount, key locked door, plexiglass window, Beige
▶ RA-ENC2	2-unit remote annunciator enclosure, 4" box mount, key locked door, plexiglass window, Beige
▶ RA-ENC3	3-unit remote annunciator enclosure, 4" box mount, key locked door, plexiglass window, Beige

NEW



K-RLCD-C

NEW



K-RLED24

NEW



K-RLED-C

SMART RELAYS

RA-300

PART#	DESCRIPTION
SRM-312W	Series 300 Smart Relay Module c/w White Enclosure, 2 Configurable Relays (NO or NC) One to One Common Alarm Common Supervisory



SRM-312W

NEW *Kidde FX Conv.*

PART#	DESCRIPTION
▶ FSRRM24	Remote Relay Module, 5 Form C contacts, jumper selectable operation, includes mounting track
▶ FSRRM-S11	Fire Alarm Control Accessory, Snap-Track for Remote Relay Module, 11"

ANNUNCIATOR BACK BOX

PART#	DESCRIPTION
BB-1001D	Semi-Flush Backbox for Series1000 Annunciators (Houses 1 Module) (12.75"W X 9"L X 1.85"D) without door measurements, WHITE Door & Black Backbox Mounts over standard electrical box by others
TH101	Thermostat Heater for Sub-Zero Applications, Requires separate 24 VAC power source (PS-24)
▶ PS24	24V AC Transformer
▶ MCH-001	BB-1000 Blank Panel Insert

NOTES:

- 1) The maximum number of remote annunciators the FA-1000 can support is 8 without the use of a remote shared display
- 2) Each remote annunciator must have a master i.e. RAM-1032TZDS or MGD-32

CONVENTIONAL DETECTION/INPUT/INITIATING DEVICES

MANUAL ALARM PULL STATION

MS-400

PART#	DESCRIPTION
MS-401	Single Stage Pull Station (N.O. with Station Closed)
NEW MS-402	Dual Stage Pull Station (Alarm Contact & Key Switch Contact are N.O. with Station Closed)
NEW MS-405	Single Stage Pull Station with additional N.O. switch (Alarm Contact is N.O. & Extra Contact is N.O. with Station Closed)
NEW MS-407	Single Stage Pull Station with additional N.C. switch (Alarm Contact is N.O. & Extra Contact is N.C. with Station Closed)
NEW MS-408	Dual Stage Pull Station with additional N.C. switch (Alarm) & Key Switch Contacts are N.O. & Extra Contact is N.C. with Station Closed)
MSDA	Manual Pull Station Double Action Lever Kit
GL004K	Glass Rod Replacement for MS-400 Series (Pkg. of 10)
BB300	Surface Mounting Box, Single Gang Red Finish



MS-401

MS-403/404

PART#	DESCRIPTION
MS403	Blue Emergency Door Control Pull Station, 2 switches one N.O. & one N.C. (other switch configuration optionally available)
MS404	Yellow Emergency Door Control Pull Station, 2 switches one N.O. & one N.C. (other switch configuration optionally available)
MSDA	Manual Pull Station Double Action Lever Kit
GL004K	Glass Rod Replacement for MS-400 Series (Pkg. of 10)
BB300	Surface Mounting Box, Single Gang Red Finish



MS403 / MS404



MSDA



GL004K

NEW MS-700

PART#	DESCRIPTION
▶ MS-702	Single Action Bilingual Two Stage Pull Station c/w Key Switch
▶ MS-710	Dual Action Bilingual Pull Station c/w Key Reset & Terminal Connection
▶ BB-700	Series 700 Surface Mount Backbox Red
▶ BB-700WP	Series 700 Weather Proof Surface Mount Backbox Red

NEW



MS-710

NEW MS-700U

PART#	DESCRIPTION
▶ MS-703U	Blue Single Action Emergency Station w/ 2 Form 'C' Contacts Key Resettable, English Only
▶ MS-704U	Yellow Single Action Emergency Station w/ 2 Form 'C' Contacts Key Resettable, English Only

MANUAL ALARM PULL STATION CONTINUED

270

PART#	DESCRIPTION
270-SPO	Single Action Pull Station, Break Glass, Single pole, N.O. Cct., screw terminal
270-SPOW	Single Action Pull Station, Break Glass, Single pole, N.O. Cct., wire leads
270-DOC	Single Action Pull Station, Break Glass, Double Pole, N.O./N.C. Cct.
270-GAO	Single Action, Two Stage Pull Station, Break Glass, Single Pole, N/O First Stage Contact & N/O Second Stage Keyswitch
270-GAO-DOC	Single Action, Two Stage Pull Station, Break Glass, Double Pole, 2 N.O. Ccts (N.O. First Stage & N.O. 2nd Stage Keyswitch)
270-GLR	Replacement Break Rods, 270 Series, 2 ³ / ₁₆ " Length, 12/Pkg
276GLR	Replacement Break Rods, 276/278 Series, 3 ¹ / ₄ " Length, 20/Pkg



270 Series



270-GLR

ABORT STATION

PART#	DESCRIPTION
SS2004ZA-EN	Momentary mushroom switch abort station, stainless steel backplate N.O. or N.C. SPST gold plated contact blocks rated for 3 amps @ 600 VAC or 1 amp @ 250 VDC 1st line of top label reads : "EXTINGUISHING SYSTEM"; 2nd line of top label reads: "ABORT STATION"; Bottom label reads "PUSH AND HOLD TO CANCEL"



SS2004ZA-EN

SMOKE DETECTION

C2M-PD

PART#	DESCRIPTION
C2M-PD1	Discontinued , Use 2151A with appropriate base (sold separately) Discontinued

100

PART#	DESCRIPTION
2151A	100 Series Photoelectric Smoke (requires plug-in base, sold separately) Replaces C2M-PD1
B110LPA	2-Wire Base for 2151A Detector, 12/24 VDC
B112LPA	4-Wire Base for 2151A Detector, 12/24 VDC
B114LPA	4-Wire Base for 2151A Detector, 12/24 VDC w/ Form "A" & "C" Relay
B116LPA	2-Wire Base for 2151A Detector, 12/24 VDC w/ Form "C" Relay



2151A

i3™

PART#	DESCRIPTION
C2WBA	i3 Photo Smoke, 2-wire, plug-in base
C2WTRBA	i3 Photo/Thermal Combo, 2-Wire, 135 Degree F Fixed Temp, plug-in base with Form C, 2 Amp Contact
C4WTR-BA	i3 Photo/Thermal Combo, 4-Wire, 135 Degree F Fixed Temp, plug-in base with Form C, 2 Amp Contact
B110LPA	Series 100 Low Profile, 2-Wire Base



C2WBA



C2WTRBA

NEW SD

PART#	DESCRIPTION
▶ SD-100-2WT-6K	2 Wire smoke heat combo (listed for mircom panels only)
▶ SD-100-4WT-6K	4 Wire smoke heat combo (listed for mircom panels only)

HEAT DETECTION

5600

PART#	DESCRIPTION
5601A	135 F Fixed Temp/ Rate of Rise Heat Detector
5602A	194 F Fixed Temp/ Rate of Rise Heat Detector
5603A	135 F Fixed Temperature Only Heat Detector
5604A	194 F Fixed Temperature Only Heat Detector



5600 Series

TD

PART#	DESCRIPTION
TD-135	135 F Fixed Temp Heat Detector, Resettable
TD-200	200 F Fixed Temp Heat Detector, Resettable



TD Series

DUCT DETECTION

NEW InnovairFlex

PART#	DESCRIPTION
D2A	Mircom 2-wire photoelectric low-flow duct smoke detector (sampling tube duct sold separately)
DST1	Metal sampling tube duct widths up to 1 ft (0.3 m)
DST15	Metal sampling tube duct widths 1 ft to 2 ft (0.3 to 0.6 m)
DST3	Metal sampling tube duct widths 2 ft to 4 ft (0.6 to 1.2 m)
DST5	Metal sampling tube duct widths 4 ft to 8 ft (1.2 to 2.4 m)
DST10	Metal sampling tube duct widths 8 ft to 12 ft (2.4 to 3.7 m)



D2A

NEW SuperDuct

PART#	DESCRIPTION
SD2W	EST SuperDuct Sensor, 2-Wire, E-Shield (sampling tube duct sold separately)
SD-T8	8-inch sampling tube
SD-T18	18-inch sampling tube
SD-T24	24-inch sampling tube
SD-T36	36-inch sampling tube
SD-T42	42-inch sampling tube
SD-T60	60-inch sampling tube
SD-T78	78-inch sampling tube
SD-T120	120-inch sampling tube



SD Series

INTELLIGENT DETECTION/INPUT/INITIATING DEVICES

INTELLIGENT SMOKE AND HEAT DETECTORS

NEW MIX-3000

PART#	DESCRIPTION
▶ MIX-3100	Mircom Low Profile Intelligent Plug in Photoelectric Smoke Sensor. Order MIX-2000 Series Base Separately
▶ MIX-3200	Mircom Low Profile Intelligent Plug in Multi-Criteria Photoelectric & Heat Sensor. Order MIX-2000 Series Base Separately
▶ MIX-3300	Mircom Low Profile Intelligent Heat Sensor Adjustable. Order MIX-2000 Series Base Separately
▶ MIX-2000	Mircom Intelligent 4" Base No Flange, c/w MIX-ADD Card
▶ MIX-2001	Mircom Low Profile Intelligent 6" E-Z Fit Base, c/w MIX-ADD Card
▶ MIX-2001R	Mircom Intelligent 6" Relay Base, c/w MIX-ADD Card, Loop Powered
▶ MIX-2001HT	Mircom Intelligent 6" Temporal Tone Sounder Base, c/w MIX-ADD Card, Requires Separate 24 VDC Power Source for Sounder
▶ MIX-ADD	Address Card For MIX-2000 Series Bases, Package of 10



NEW KIR

PART#	DESCRIPTION
▶ KIR-PD	Intelligent Optical Smoke Detector
▶ KIR-PHD	Intelligent Multisensor Smoke and Heat Detector
▶ KIR-HD	Intelligent fixed temperature/Rate-of-rise heat detector
▶ KI-SB	Detector Mounting Base - Standard
▶ KI-SB4	4-inch Detector Mounting Base c/w Trim Skirt
▶ KI-RB	Detector Mounting Base w/Relay
▶ KI-RB4	4-inch Detector Mounting Base w/Relay, c/w Trim Skirt
▶ KI-IB	Detector Mounting Base w/Fault Isolator
▶ KI-IB4	4-inch Detector Mounting Base w/ Fault Isolator, c/w Trim Skirt



SIGA

PART#	DESCRIPTION
SIGAPS	Replaced by P/N# SIGAPD
SIGAPD	Intelligent Optical Smoke Detector
SIGAPHS	Replaced by P/N# SIGA-PHD
SIGA-PHD	Intelligent Multisensor Smoke and Heat Detector
SIGAIPHS	Replaced by P/N# SIGA-PHD
SIGAHFS	Replaced by P/N# SIGA-HFD
SIGA-HFD	Intelligent fixed temperature heat detector
SIGAHRS	Replaced by P/N# SIGAHRD
SIGA2HRS	Replaced by P/N# SIGAHRD
SIGAHRD	Intelligent fixed temperature/Rate-of-rise heat detector
SIGASB	Detector Mounting Base



INTELLIGENT DUCT DETECTORS

NEW *MIX-DH3100*



PART#	DESCRIPTION
▶ MIX-DH3100	Mircom Intelligent Photoelectric Duct Smoke Detector, Order Duct Tubes Separately
▶ MIX-DH3100R	Mircom Intelligent Photoelectric Duct Smoke Detector c/w Relay, Order Duct Tubes Separately
▶ DST1	1 ft Metal Sampling Tube for InnovairFlex Duct Detect
▶ DST15	1.5 ft Metal Sampling Tube for InnovairFlex Duct Detect
▶ DST3	3 ft Metal Sampling Tube for InnovairFlex Duct Detect
▶ DST5	5 ft Metal Sampling Tube for InnovairFlex Duct Detect
▶ DST10	10 ft Metal Sampling Tube for InnovairFlex Duct Detect

NEW



MIX-DH3100R

NEW *SIGA*

PART#	DESCRIPTION
▶ SIGASD	Intelligent SuperDuct Detector, Order Duct Tubes Separately
▶ SIGADH	Duct Detector Housing
▶ SD-T8	8-inch sampling tube
▶ SD-T18	18-inch sampling tube
▶ SD-T24	24-inch sampling tube
▶ SD-T36	36-inch sampling tube
▶ SD-T42	42-inch sampling tube
▶ SD-T60	60-inch sampling tube
▶ SD-T78	78-inch sampling tube
▶ SD-T120	120-inch sampling tube

NEW *Kidde FX Intell.*

PART#	DESCRIPTION
▶ FX-PDD	Intelligent Addressable Optical Duct Detector, Order Duct Tubes Separately
▶ SD-T8	8-inch sampling tube
▶ SD-T18	18-inch sampling tube
▶ SD-T24	24-inch sampling tube
▶ SD-T36	36-inch sampling tube
▶ SD-T42	42-inch sampling tube
▶ SD-T60	60-inch sampling tube
▶ SD-T78	78-inch sampling tube
▶ SD-T120	120-inch sampling tube

NEW



FX-PDD

INTELLIGENT INPUT/OUTPUT MODULES

NEW *MIX-100*



PART#	DESCRIPTION
▶ MIX-101P	Mircom Intelligent Priority Mini Module, Supports Contact Devices Only, Wired in Class A, Style D or Class B, Style B
▶ MIX-100P	Mircom Intelligent Priority Monitor Module, Supports Contact Devices Only, Wired in Class A, Style D or Class B, Style B, Mount in 4" Square Electrical Box by Others
▶ MIX-100R	Mircom Intelligent Relay Output Module, c/w 2 Form 'C' Contacts 2 Amp @ 24 VDC (Resistive) or 1 Amp @ 30 VDC (Inductive), Mounts in 4" Square Electrical Box by Others
▶ MIX-100S	Mircom Intelligent Supervised Output Module, Mounts in 4" Square Electrical Box by Others
▶ MIX-100X	Mircom Line Isolator Module, Mounts in Single Gang or 4" Square Electrical Box by Others

NEW *Kidde FX Intell.*

PART#	DESCRIPTION
▶ FX-IDC1A	Analog Class A Single Input Module
▶ FX-IDC1B	Analog Single Input Mini Module
▶ FX-2WIRE	Analog Class A-B Two-Wire Module
▶ FX-IDC2B	Analog Dual Input Module
▶ FX-IDCWS	Analog Dual Input Waterflow-Supervisory Module
▶ FX-IS0	Analog SLC Fault Isolator Module
▶ FX-NAC	Analog NAC Module
▶ FX-RLY	Analog Contact Relay Module

NEW



MIX-101P

NEW



MIX-100S

NEW



MIX-100X

NEW



MIX-101P

NEW



FX-IDC1A/FX-IDC1B

INTELLIGENT INPUT/OUTPUT MODULES CONTINUED

SIGA

PART#	DESCRIPTION
SIGAIM	Fault Isolator Module
SIGACT1	Intelligent Single Input Module
SIGACT2	Intelligent Dual Input Module
SIGACR	Intelligent Control Relay Module, Std Mount
SIGAMCR	Control Relay Module (UIO Mount)
SIGAMM1	Monitor Module
SIGA-MCC1	Single Input Signal Module (UIO Mount)



SIGACT1



SIGACR

INTELLIGENT PULL STATION

NEW MS-400ID

PART#	DESCRIPTION
▶ MS-401ID	Intelligent Single Pull Station (N.O. with Station Closed), Bilingual
▶ MS-402ID	Intelligent Dual Stage Pull Station (Alarm Contact & Key Switch Contact are N.O. with Station Closed) c/w Two Addressable Modules, Bilingual
▶ BB300	Surface Mounting Box, Single Gang Red Finish

NEW MS-700ID

PART#	DESCRIPTION
▶ MS-710ID	Intelligent Die Cast, Single Stage, Dual Action Bilingual Pull Station c/w Key Reset, Addressable Module & Terminal Connections, Bilingual
▶ BB-700	Series 700 Surface Mount Backbox Red
▶ BB-700WP	Series 700 Weather Proof Surface Mount Backbox Red

NEW Kidde FX Intell.

PART#	DESCRIPTION
▶ FX-270	Pull Station, Single-Action, Metal, Rotary Dials.
▶ FX-278	Pull Station, Double-Action, Lexan, Rotary Dials.



FX-270

SIGA

PART#	DESCRIPTION
SIGA270	Intelligent One Stage Manual Pull Station
SIGA270P	Intelligent Two Stage (Presignal) Manual Pull Station
SIGC-270C	One Stage Fire Alarm Station c/w 1 "C" Contact, English Markings
SIGC-270PC	Two Stage (Presignal) Fire Alarm Station w. Aux. Contact, English Markings
SIGC-270PBC	Two Stage (Presignal) Fire Alarm Station w. Aux. Contact, French/ English Markings



SIGA270



SIGC-270PC



SIGC-270PBC

SIGNALING/OUTPUT DEVICES

HORNS AND STROBES

Genesis® G1

PART#	DESCRIPTION
G1RP	Genesis Steady Horn, Red, Wall Mnt
G1P	Genesis Steady Horn, White, Wall Mnt
G1RF-HDVM	Genesis Horn-Strobe w/ "FIRE" Marking, Red, Wall Mnt (selectable 15, 30, 75 or 110 cd output, selectable high/low dB output)



G1P



G1RF-HDVM

NEW MGC FH-400 Horns

PART#	DESCRIPTION
FH400RR	Red Wall/Ceiling Mount Horn
FH400WW	White Wall/Ceiling Mount Horn

NEW



FH400RR

NEW



FH400WW

NEW MGC FS-400 Strobes

PART#	DESCRIPTION
FS400RR	Red Wall Mount Strobe
FS400WW	White Wall Mount Strobe
FS400CRR	Red Ceiling Mount Strobe
FS400CWW	White Ceiling Mount Strobe

NEW



FS400RR

NEW



FS400WW

NEW MGC FHS-400 Horn/Strobes

PART#	DESCRIPTION
FHS400RR	Red Wall Mount Horn/Strobe
FHS400WW	White Wall Mount Horn/Strobe
FHS400CRR	Red Ceiling Mount Horn/Strobe
FHS400CWW	White Ceiling Mount Horn/Strobe

NEW



FHS400RR

NEW



FHS400WW

MGC 400 Back Boxes

PART#	DESCRIPTION
BB-400R	Red Surface Mount Back Box
BB-400W	White Surface Mount Back Box



BB-400R

MH-25 Mini-Horns

PART#	DESCRIPTION
MH25W	Mini-piezo, 24 VDC, white, flush Mount. For Surface Mount use BB-300W
MH25R	Mini-piezo, 24 VDC, red, flush Mount. For Surface Mount use BB-300
MHS25RA	Mini-piezo, 24VDC, Flush, Red Silenceable c/w Silence Switch. Alarm LED, Re-sound Timer, Terminal Connection, For Surface Mount use BB-300 *White available by special order MH-S25WA
SIGSM100	Signal & Speaker Silence Module c/w Silence Switch & Max 10 Minute Re-sound Circuit Supports: 25V or 70V Speakers or 24VDC Electronic Signals Mounts in Standard 4" Square Electrical Box c/w Single Gang Plaster Ring Requires Fire Alarm Signal Circuit for Power
BB300	Surface Mounting Box, Single Gang Red Finish



MH25W



MH25R



SIGSM100

HORNS AND STROBES CONTINUED

682 Mini-Horn

PART#	DESCRIPTION
6821C	Mini-Horn, White

683 Mini-Horn

PART#	DESCRIPTION
6831C	Silenceable Mini-Horn, White
6841C	Signal Silence Unit, White



6831C

MIRCOM SUPERVISED AND NON SUPERVISED SUITE ISOLATORS

PART#	DESCRIPTION
CNSIS-204	Conventional Signal Suite Isolator, 4 Non Supervised Suite Isolators, White Finish, Mounts in 4" Square Electrical Box
CSIS-202A	Conventional Signal Suite Isolator, 2 Supervised Suite Isolators, White Finish, Mounts in 4" Square Electrical Box

ALARM BELLS AND ACCESSORIES

BL-6B/BL-10B

PART#	DESCRIPTION
BL6B	Mircom 6" 24V DC Motorized Aluminum Bell, 12 MA Current Draw, Terminal Connection Mounts on Standard 4" Square Outlet Box by Others, Requires MP-101 for Mounting on 4" Octagon Outlet Box
BL10B	Mircom 10" 24V DC Motorized Aluminum Bell, 23 MA Current Draw, Terminal Connection Mounts on Standard 4" Square Outlet Box by Others, Requires MP-101 for Mounting on 4" Octagon Outlet Box
BB206WP	Weather Proof Bell Backbox for BL-6A, BL-6B, BL-10A & BL-10B
MP-101	Universal Mounting Plate for BL-6A, BL-6B or BL-10A, BL-10B Required When Mounting Bells on Switch or 4" Octagon Outlet Box
SDM240	SERIES 200 SYNC MODULE
BB-210	Backbox/Flush for mounting 6" or 10" Bell. Ceiling or Wall Mount



BL6B



BL10B

SSV Series

PART#	DESCRIPTION
SSV12006A	Mircom 6" 120VAC Motorized Steel Bell
SSV12010A	Mircom 10" 120VAC Motorized Steel Bell
WBB	Weatherproof Backbox for SSM and SSV Series



SSV12006A



SSV12010A

NEW MB Series

PART#	DESCRIPTION
▶ MB6-24	EST 6" 24V DC Motorized Bell
▶ MB10-24	EST 10" 24V DC Motorized Bell
▶ MPFP-2	Flush Mounting Plate, Red, for MB Series
▶ WBB-1	Weatherproof Mounting Box, MB Series

NEW REPLACEMENT MOTHER BOARDS

PART#	DESCRIPTION
▶ RB-FA1000DBSW	FA-1000Kua Display Board W/ Switches
▶ RB-FA1000MB	FA-1000 Main Pc Board
▶ RB-FA101T	FA-101T Main Pc Board
▶ RB-FA1025T	FA-1025T Main Pc Board
▶ RB-FA102T	FA-102T Main Pc Board
▶ RB-FA103	REPLACEMENT BOARD FOR FA-103 PANEL
▶ RB-FA106	REPLACEMENT BOARD FOR FA-106 PANEL
▶ RB-FA262DB	FA-262 Display Board
▶ RB-FA262MB	FA-262 Main Pc Board
▶ RB-FA265DB	FA-265 Display Board
▶ RB-FA265MB	FA-265 Main Pc Board
▶ RB-FA300MB	FA-300-6Dr Main Pc Board
▶ RB-FA300MBD	FA-300-6Ddr Main Pc Board
▶ RB-FA301MB12DD	FA-301-12Ddr Main Pc Board
▶ RB-FA301MB12L	FA-301-12Lr (W) Main Pc Board
▶ RB-FA301MB12LD	FA-301-12Ld (W) Main Pc Board
▶ RB-FA301MB8L	FA-301-8L Main Pc Board
▶ RB-FA301MB8LD	FA-301-8Ld Main Pc Board
▶ RB-FR320MB	FR-320 Main Pc Board
▶ RB-FR320PS	FR-320, Fa-300-6L & Fx-350 Power Supply
▶ RB-FX351MBL	FX-351-L MAIN PC BOARD
▶ RB-FX351MBLD	FX-351-LD REPLACEMENT MAIN BOARD

FIRE ALARM ELECTRICAL CABLE

Unarmoured Unshielded Cable

Fire Alarm 18 AWG Unshielded 300V is CSA certified to CSA C22.2 No. 208. Fire Alarm and Signal Cable. Conductors are cabled together. A PVC jacket is applied over the twisted assembly.

PART#	DESCRIPTION
FAG1803CB0300	Fire Alarm 3/C 18 AWG Unshielded 300V, Red, 300m/Spool
FAG1805CB0300	Fire Alarm 5/C 18 AWG Unshielded 300V, Red, 300m/Spool

Shielded Unarmoured Cable

Fire Alarm 18 AWG Unshielded 300V is CSA certified to CSA C22.2 No. 208. Conductors are cabled together with an overall shield and drain. A PVC jacket is applied over the twisted assembly.

PART#	DESCRIPTION
FAG1803CB1300	Fire Alarm 3/C 18 AWG Shielded 300V, Red, 300m/Spool
FAG1805CB1300	Fire Alarm 5/C 18 AWG Shielded 300V, Red, 300m/Spool



Shielded Unarmoured

Armoured Unshielded Cable

Fire Alarm Armoured and Unshielded 300V is CSA certified to CSA C22.2 No. 208. Conductors are cabled together. A PVC jacket is applied over the twisted assembly. An aluminum interlocking armour is applied over the inner jacket.

PART#	DESCRIPTION
AC140499150	Fire Alarm 4/C 14 AWG Unshielded, Armoured 300V, 150m/Spool
FAA1803CB0150	Fire Alarm 3/C 18 AWG Unshielded, Armoured 300V, 150m/Spool
FAA1805CB0150	Fire Alarm 5/C 18 AWG Unshielded, Armoured 300V, 150m/Spool



Armoured Unshielded

FIRE SPRINKLER MONITORING

ALARM PRESSURE SWITCHES

System Sensor EPSA10 Series

System Sensor **EPSA10 Series** field-adjustable pressure switches are designed for use in wet, dry, deluge and pre-action automatic sprinkler systems to indicate a discharge from a sprinkler.

PART#	DESCRIPTION
EPSA10-1P	Alarm Pressure Switch, One SPDT, Plastic Fitting
EPSA10-2P	Alarm Pressure Switch, Two SPDT, Plastic Fitting



EPSA10-1P

System Sensor EPSA40 Series

System Sensor **EPSA40 Series** supervisory field-adjustable pressure switches are intended for dry pipe systems or pressure tanks and water supplies of automatic water control valves. This model offers a choice of initiating low or high/low pressure monitoring alarms, in a variety of pressure ranges.

PART#	DESCRIPTION
EPSA40-1P	Low Pressure Supervisory Switch, One SPDT, 10–100 PSI - Plastic Fitting
EPSA40-2P	High/Low Pressure Supervisory Switch, Two SPDT, 10–100 PSI - Plastic Fitting

System Sensor EPSA120 Series

System Sensor **EPSA120 Series** supervisory field-adjustable pressure switches are intended for dry pipe systems or pressure tanks and water supplies of automatic water control valves. This model offers a choice of initiating low or high/low pressure monitoring alarms, in a variety of pressure ranges.

PART#	DESCRIPTION
EPSA120-1P	Low pressure supervisory switch, one SPDT, 10–200 PSI
EPSA120-2P	High/low pressure supervisory switch, two SPDT, 10–200 PSI

ATTRIBUTE	SPECIFICATION					
Item #	EPSA10-1P	EPSA10-2P	EPSA40-1P	EPSA40-2P	EPSA120-1P	EPSA120-2P
Type of Pressure Switch	Alarm Waterflow	Alarm Waterflow	Supervisory Low	Supervisory High/Low	Supervisory Low	Supervisory High/Low
Switch Type	1 SPDT	2 SPDT	1 SPDT	2 SPDT	1 SPDT	2 SPDT
Listing	ULC, FM	ULC, FM	ULC, FM	ULC, FM	ULC, FM	ULC, FM
Enclosure Rating	NEMA 4	NEMA 4	NEMA 4	NEMA 4	NEMA 4	NEMA 4
PSI Range	4-20	4-20	10-100	10-100	10-200	10-200

SUPERVISORY SWITCHES

System Sensor Supervisory Switches

System Sensor's electric supervisory switches are used to monitor the open position of Outside Screw and Yoke (OS&Y) type gate valves, post indicator and butterfly control valves (PIBV2A) and other type of valves. System Sensor's PSP1A plug-in switch is a special application supervisory switch designed for applications where no other type of listed valve supervisory switch can be used. Each feature a NEMA 3R-rated enclosure that is also tamper resistant. ULC listed and FM approved.

PART#	DESCRIPTION
OSY2A	Outside Screw and Yoke valve supervisory switch
PIBV2A	Post Indicator/Butterfly valve supervisory switch
PSP1A	Plug-in Special Purpose Supervisory Switch



OSY2A



PIBV2A



PSP1A

We are in the business of growing your business

WATERFLOW DETECTORS

System Sensor WFDNA Series

The WFDNA Series waterflow detectors from System Sensor consists of a rugged, NEMA 4-rated enclosure that is more damage resistant than previous metal designs. The waterflow detector is designed for both indoor and outdoor use, with the widest available temperature range, from 0°C to 66°C (32°F to 150°F). The System Sensor WFDNA series is compatible with schedule 7 through 40 steel pipe, for sizes 2 in. through 4 in. and compatible with schedule 10 through 40 steel pipe, sizes 6 in. through 8 in., and can be mounted in a vertical or horizontal position.

PART#	DESCRIPTION
WFD20NA	2" Waterflow switch
WFD25NA	2.5" Waterflow switch
WFD30NA	3" Waterflow switch
WFD40NA	4" Waterflow switch
WFD50NA	5" Waterflow switch
WFD60NA	6" Waterflow switch
WFD80NA	8" Waterflow switch



WFD25NA



WFD30NA



WFD40NA

ATTRIBUTE	SPECIFICATION						
Item#	WFD20NA	WFD25NA	WFD30NA	WFD40NA	WFD50NA	WFD60NA	WFD80NA
Switch Type	2 SPDT	2 SPDT	2 SPDT	2 SPDT	2 SPDT	2 SPDT	2 SPDT
Listing	ULC	ULC	ULC	ULC	ULC	ULC	ULC
Enclosure Rating	NEMA 4	NEMA 4	NEMA 4	NEMA 4	NEMA 4	NEMA 4	NEMA 4
Fits Schedule Piping	7 through 40	7 through 40	7 through 40	7 through 40	10 through 40	10 through 40	10 through 40
Pipe Size	2"	2½"	3"	4"	5"	6"	8"
Hole Size	1¼"	1¼"	2"	2"	2"	2"	2"

FIRE ALARM BATTERIES

ALKALINE BATTERIES

Energizer® ALKALINE BATTERIES are designed for today's heavy current or continuous use applications. These batteries have no mercury added; therefore, special disposal is not required. They operate well with temperature extremes (-20°F to 130°F), with excellent shelf life.

PART#	DESCRIPTION
ALK92	AAA Alkaline Battery, Energizer Industrial
ALK91	AA Alkaline Battery, Energizer Max
ALK93	C Alkaline Battery, Energizer Industrial
ALK95	D Alkaline Battery, Energizer Max
ALK22	9V Alkaline Battery, Energizer Max



ALK92



ALK91



ALK93



ALK95



ALK22

LITHIUM BATTERIES

For the countless electronic gadgets you can't live without, rely on Energizer® Advanced Lithium Batteries.

- Up to 10-year backup battery in AC-powered smoke detectors
- Last up to 20% longer in toys versus Energizer® MAX®
- Weigh ¼ less than standard alkaline
- Perform in extreme temperatures from -40°F to 140°F
- Leak-resistant construction

PART#	DESCRIPTION
U9VL	9V Lithium Battery, Energizer Advanced



U9VL

SEALED LEAD ACID BATTERIES

STEEL EMERGENCY LIGHT BATTERIES are one of the most powerful and economical batteries you can buy.

Batteries will be shipped separately from other items ordered and those items will be shipped according to our regular freight policy **TRANSPORT TRUCK TAILGATE CHARGES ARE EXTRA.**

All battery orders placed before 1pm Eastern Standard Time will be shipped same day! Orders placed after will be shipped next day. The approximate shipping times via GROUND to major cities across Canada are as follows:

Ontario and Quebec – Next day delivery (some rural areas may be two days)

East Coast – NS, NB, PEI – 2 days; NFLD – 4 days

Central Canada (Manitoba, Saskatchewan) – 2 – 3 days

Western Canada – 3 days to Calgary / Edmonton

NWT, YK – 6 days

BC - Next day

PART#	DESCRIPTION	LxWxH	CASE QTY
PRB121	12V 1.3AH	3 ¹ / ₁₆ " x 2 ¹ / ₁₆ " x 1 ¹ / ₁₆ "	20
RS125	12V 5AH	3 ¹ / ₂ " x 2 ³ / ₄ " x 4"	10
RS127	12V 7.2AH	6" x 2 ¹ / ₂ " x 3 ³ / ₄ "	8
RS1212	12V 12AH	6" x 3 ⁷ / ₈ " x 3 ³ / ₄ "	4
RS1218	12V 18AH	7 ¹ / ₈ " x 3" x 6 ¹ / ₂ "	2
RS1226	12V 26AH	6 ¹ / ₂ " x 6 ⁷ / ₈ " x 5"	1
RS1233	12V 33AH	7 ² / ₃ " x 6 ¹ / ₈ " x 7 ¹ / ₈ "	1
RS1242*	12V 42AH	7 ³ / ₄ " x 6 ¹ / ₂ " x 6 ³ / ₄ "	1
RS1255*	12V 55AH	9 ³ / ₈ " x 5 ¹ / ₅ " x 8 ¹ / ₁₆ "	1

*Nut & Bolt Terminals

ZONE 1 - ON (EXCEPT THUNDER BAY), PQ

ZONE 2 - MB, NS, SK, THUNDER BAY, NB

ZONE 3 - AB, BC, NFLD, PEI

ZONE 4 - NWT, YK



RS125



RS127



RS1212



RS1218



RS1226



RS1233



RS1242



RS1255

MORE BATTERIES AVAILABLE. CONTACT CUSTOMER SERVICE FOR MORE INFORMATION.

SMOKE, CO ALARMS & ACCESSORIES

SMOKE ALARMS

10 Year Battery Operated

The alarms are powered by sealed, long-life lithium batteries for 10 years (the life of the alarm). The National Fire Protection Association recommends replacing smoke alarms every 10 years. Alarms come with Test, Hush and Tamper Resistant security feature.

PART#	MFG/MODEL#	DESCRIPTION
910	0910CA / i9010CA	Battery Operated, 10 Year, Ion Smoke
SA305CNA		Battery Operated, 10 Year, Ion Smoke
P3010B	P3010B-CA	Battery Operated, 10 Year, Talking, Photo Smoke
P3010H	P3010H-CA	Battery Operated, 10 Year, LED Light, Photo Smoke
P3010K	P3010K-CA	Battery Operated, 10 Year, Photo Smoke
NEW PR710A		Low Profile, Battery Operated, 10 Year, Photo Smoke

Model Selection Table:

ITEM#	BRAND	SMOKE SENSOR	POWER SOURCE	SPECIAL FEATURES
910	Kidde	Ionization	10 Year Lithium	
SA305CNA	BRK	Ionization	10 Year Lithium	
P3010B	Kidde	Photoelectric	10 Year Lithium	Voice Warning
P3010H	Kidde	Photoelectric	10 Year Lithium	LED Light
P3010K	Kidde	Photoelectric	10 Year Lithium	
PR710A	BRK	Photoelectric	10 Year Lithium	Low Profile



Battery Operated

Battery powered alarms can be installed easily, and all models include a test button, hush button, power indicator light, battery locking, and low battery warning indicator.

PART#	MFG/MODEL#	DESCRIPTION
916	0916KCA / i9060CA	Battery Operated, Ion Smoke
I9040	i9040CA	Battery Operated, Ion Smoke, Small
FG250BA		Battery Operated, Ion Smoke
SA303CNA		Battery Operated, Ion Smoke
NEW 976	0976CA / i9070CA	Front-Load Battery Operated, Ion Smoke
NEW 918	0918KCA / i9080CA	Battery Operated, Ion Smoke, LED Safety Light
PE9	PE9KCA / P9050CA	Battery Operated, Photo Smoke
NEW PI9010CA	PI9010CA	Battery Operated, Photo/Ion Smoke

Model Selection Table:

ITEM#	BRAND	SMOKE SENSOR	POWER SOURCE	SPECIAL FEATURES
916	Kidde	Ionization	9V	
I9040	Kidde	Ionization	9V	Small 4" Dia.
FG250BA	First Alert	Ionization	9V	
SA303CNA	First Alert	Ionization	9V	
976	Kidde	Ionization	9V	Front-Load Battery
918	Kidde	Ionization	9V	LED Safety Light
PE9	Kidde	Photoelectric	9V	
PI9010CA-N	Kidde	Photo/Ion	9V	



SMOKE ALARMS CONTINUED

Hardwired AC Operated

We offer a full range of 120V AC hardwired life safety products with interconnect capability to provide the most immediate and complete system available. When any one interconnected alarm is triggered by smoke, all interconnected alarms within the home sound an immediate warning.

Please note that for the **strobe units**, the battery back-up does not power the strobe.

PART#	MFG/MODEL#	DESCRIPTION
1235	P1235CA / i12020ACA	120V Hardwire, Ion Smoke
9120A		120V Hardwire, Ion Smoke
I12010S-CA	i12010S-CA / i12010SCA	120V Hardwire, 10 Year, Ion Smoke, Battery Backup
9120LBLA		120V Hardwire, 10 Year, Ion Smoke, Battery Backup
1275	P1275CA / i12040ACA	120V Hardwire, Ion Smoke, Battery Backup
1276	P1276CA / i12060ACA	120V Hardwire, Ion Smoke, Battery Backup
9120BA		120V Hardwire, Ion Smoke, Battery Backup
7016TCA		120V Hardwire, Photo Smoke, Zero Waste
P4010ACLEDSCA	P4010ACLEDSCA	120V Hardwire, Photo Smoke and Strobe, 10 Year, Battery Backup
PE120	PPE120CA / P12040CA	120V Hardwire, Photo Smoke, Battery Backup
7016BTCA		120V Hardwire, Photo Smoke, Battery Backup, Zero Waste
7010BSLA		120V Hardwire, Photo Smoke and Strobe, Battery Backup
SL177A		120V 177 cd. Strobe for BRK Alarms
NEW PI2010CA-N	PI2000CA / PI2010CA	120V Hardwire, Photo/Ion Smoke, Battery Backup



Model Selection Table:

ITEM#	BRAND	SMOKE SENSOR	BATTERY BACKUP	POWER SOURCE	INTERCONNECT	SPECIAL FEATURES
1235	Kidde	Ionization	None	120V AC	Max 24 Units, 18 Initiating	
9120A	BRK	Ionization	None	120V AC	Max 18 Units, 12 Initiating	Alarm Locate
I12010S-CA	Kidde	Ionization	10 Year Lithium	120V AC with 10 Year Lithium	Max 24 Units, 18 Initiating	Voice Warning
9120LBLA	BRK	Ionization	10 Year Lithium	120V AC with 10 Year Lithium	Max 18 Units, 12 Initiating	
1275	Kidde	Ionization	9V	120V AC with Battery Backup	Max 24 Units, 18 Initiating	
1276	Kidde	Ionization	9V	120V AC with Battery Backup	Max 24 Units, 18 Initiating	Front-Load Battery
9120BA	BRK	Ionization	9V	120V AC with Battery Backup	Max 18 Units, 12 Initiating	Alarm Locate
7016TCA	BRK	Photoelectric	None	120V AC	Max 18 Units, 12 Initiating	Alarm Locate
P4010ACLEDSCA	Kidde	Photoelectric	10 Year Lithium	120V AC with 10 Year Lithium	Max 24 Units	Voice Warning, Integrated Strobe
PE120	Kidde	Photoelectric	9V	120V AC with Battery Backup	Max 24 Units, 18 Initiating	
7016BTCA	BRK	Photoelectric	9V	120V AC with Battery Backup	Max 18 Units, 12 Initiating	Alarm Locate
7010BSLA	BRK	Photoelectric	AAA	120V AC with Battery Backup	Max 18 Units, 12 Initiating	Alarm Locate, Integrated Strobe
PI2010CA-N	Kidde	Photo/Ion	9V	120V AC with Battery Backup	Max 24 Units, 18 Initiating	

We are in the business of growing your business

SMOKE ALARMS CONTINUED

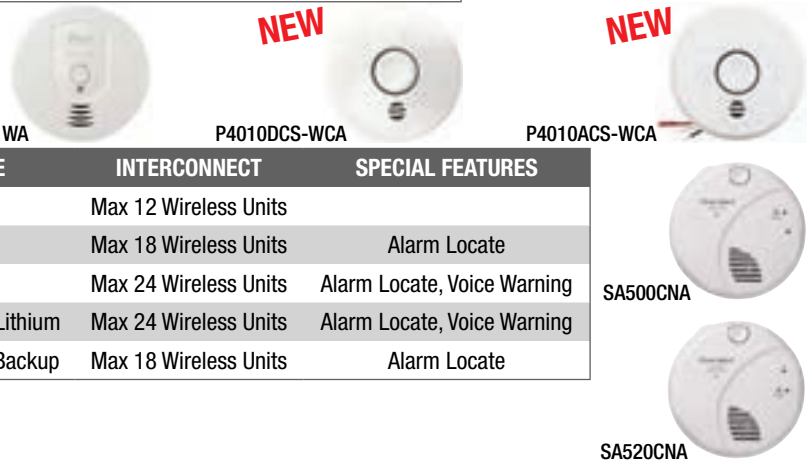
Wireless Interconnect

For Residential use. By linking together wirelessly, when one alarm sounds **ALL** of the alarms in the system will sound. The **FIRST ALERT** system allows you to replace any existing hardwired alarm with the SA520 "Bridge Unit" Smoke Alarm and the wirelessly connect up to 18 "OneLink" battery alarms with no additional wiring.

PART#	MFG/MODEL#	DESCRIPTION
201WA	900-0201-003 / RF-SM-DC-CA	Wireless, Battery Operated, Ion Smoke
SA500CNA		Wireless, Battery Operated, Photo Smoke
NEW P4010DCS-WCA		Wireless, Battery Operated, 10 Year, Photo Smoke
NEW P4010ACS-WCA	P4010ACS-WCA / P4010ACS-WCA	Wireless, 120V Hardwire, Photo Smoke, 10 Year, Battery Backup
SA520CNA		Wireless, 120V Hardwire, Photo Smoke, Battery Backup "Bridge Unit"

Model Selection Table:

ITEM#	BRAND	SMOKE SENSOR	POWER SOURCE	INTERCONNECT	SPECIAL FEATURES
201WA	Kidde	Ionization	AA	Max 12 Wireless Units	
SA500CNA	First Alert	Photoelectric	AA	Max 18 Wireless Units	Alarm Locate
P4010DCS-WCA	Kidde	Photoelectric	10 Year Lithium	Max 24 Wireless Units	Alarm Locate, Voice Warning
P4010ACS-WCA	Kidde	Photoelectric	120V AC with 10 Year Lithium	Max 24 Wireless Units	Alarm Locate, Voice Warning
SA520CNA	First Alert	Photoelectric	120V AC with Battery Backup	Max 18 Wireless Units	Alarm Locate



CARBON MONOXIDE ALARMS

10 Year Battery Operated

The alarms are powered by sealed, long-life lithium batteries for 10 years (the life of the alarm). Alarms come with Test, Hush and Tamper Resistant security feature.

PART#	MFG/MODEL#	DESCRIPTION
C3010	C3010-CA	Battery Operated, 10 Year, CO Alarm
C3010D	C3010D-CA	Battery Operated, 10 Year, CO Alarm, Digital

Model Selection Table:

ITEM#	BRAND	DISPLAY	POWER SOURCE	SPECIAL FEATURES
C3010	Kidde	None	10 Year Lithium	
C3010D	Kidde	Digital	10 Year Lithium	Voice Warning, Peak Level Memory



Battery Operated

Kidde battery-operated alarms are easy to install and keep working even if there is a power outage. Models feature a test/reset Button to test the unit for proper operation and resets the carbon monoxide alarm.

PART#	MFG/MODEL#	DESCRIPTION
233	900-0233 / KN-COB-B-LS-CA	Battery Operated, CO Alarm
NEW 230	900-0230 / KN-COPP-B-LS-CA	Digital Battery Operated, CO Alarm

Model Selection Table:

ITEM#	BRAND	DISPLAY	POWER SOURCE	SPECIAL FEATURES
233	Kidde	None	AA	
230	Kidde	Digital	AA	Peak Level Memory



CARBON MONOXIDE ALARMS CONTINUED

Hardwired AC Operated

We offer a full range of 120V AC hardwired life safety products with interconnect capability to provide the most immediate and complete system available. When any one interconnected alarm is triggered by carbon monoxide, all interconnected alarms within the home sound an immediate warning. These 120V Hardwire units all feature battery backup, test/reset and tamper resistant security.

PART#	MFG/MODEL#	DESCRIPTION
900-0128	KN-COB-IC-CA	120V Hardwire, CO Alarm, Battery Backup
C05120	C05120BNA	120V Hardwire, CO Alarm, Battery Backup



900-0128



C05120

Model Selection Table:

ITEM#	BRAND	BATTERY BACKUP	POWER SOURCE	INTERCONNECT	SPECIAL FEATURES
900-0128	Kidde	9V	120V AC with Battery Backup	Max 24 Units, 18 Initiating	
C05120	BRK	9V	120V AC with Battery Backup	Max 18 Units, 12 Initiating	Alarm Locate

Plug-In AC Operated

Kidde plug-in alarms easily plug into standard household outlets. Most models include battery backup, for protection during power outages.

PART#	MFG/MODEL#	DESCRIPTION
NEW KN-COB-DP2CA	900-0263CO-CA	Plug-in CO Alarm, Battery Backup
900-0235	KN-COB-DP-LS-CA	Plug-in CO Alarm, Battery Backup
KNCOPP3	900-0076	Digital Plug-in CO Alarm, Battery Backup
NEW 900-0280CA	KN-COP-DP-10YLCA	Digital Plug-in CO Alarm, 10 Year, Battery Backup
KNCOEG3H	900-0113-05 / KN-COEG-3	Digital Plug-in CO, Propane & Natural Gas Alarm, Battery Backup

NEW



KN-COB-DP2CA



900-0235



KNCOPP3

NEW



900-0280CA



KNCOEG3H

Model Selection Table:

ITEM#	BRAND	DISPLAY	BATTERY BACKUP	POWER SOURCE	SPECIAL FEATURES
KN-COB-DP2CA	Kidde	None	AA	AC Plug-In with Battery Backup	
900-0235	Kidde	None	9V	AC Plug-In with Battery Backup	
KNCOPP3	Kidde	Digital	9V	AC Plug-In with Battery Backup	Peak Level Memory
900-0280CA	Kidde	Digital	10 Year Lithium	AC Plug-In with 10 Year Lithium	Peak Level Memory
KNCOEG3H	Kidde	Digital	9V	AC Plug-In with Battery Backup	Peak Level Memory

Wireless Interconnect

For home residential use only. Wireless alarms interconnect with each other and when one sounds they all sound. Models all feature single button test/silence.

PART#	DESCRIPTION
C0500A	Wireless Battery Operated, CO Alarm

Model Selection Table:

ITEM#	BRAND	POWER SOURCE	SPECIAL FEATURES
C0500A	BRK	AA	Alarm Locate



C0500A

SMOKE/CO COMBINATION ALARMS

10 Year Battery Operated

Combination alarms offer protection from two deadly threats in one unit. 10-year sealed battery alarms offer a variety of benefits to those who rely on continuous battery-operated smoke and carbon monoxide detection in their homes. The alarms are powered by sealed, long-life lithium batteries or 9V batteries for 10 years (the life of the alarm).

PART#	MFG/MODEL#	DESCRIPTION
NEW PRC700A		Low Profile, Battery Operated, 10 Year, Smoke/CO Combo
NEW PRC700VA		Low Profile, Battery Operated, 10 Year, Smoke/CO Combo, Voice
P3010LCO	P3010L-CO-CA	Battery Operated, 10 Year, Smoke/CO Combo
NEW PRC710A		Low Profile, Battery Operated, 10 Year, Smoke/CO Combo
NEW PRC710VA		Low Profile, Battery Operated, 10 Year, Smoke/CO Combo, Voice



P3010LCO

Model Selection Table:

ITEM#	BRAND	SMOKE SENSOR	POWER SOURCE	SPECIAL FEATURES
PRC700A	BRK	Photoelectric	9V	Low Profile
PRC700VA	BRK	Photoelectric	9V	Low Profile, Voice Warning
P3010LCO	Kidde	Photoelectric	10 Year Lithium	Voice Warning
PRC710A	BRK	Photoelectric	10 Year Lithium	Low Profile
PRC710VA	BRK	Photoelectric	10 Year Lithium	Low Profile, Voice Warning

Battery Operated

Combination alarms offer protection from two deadly threats in one unit. Many models offer an exclusive voice warning system that eliminates confusion and clearly warns you and your family of a fire or carbon monoxide danger. Combo alarms can save space, and you'll only need to change and test batteries in one device rather than two.

PART#	MFG/MODEL#	DESCRIPTION
220	900-0220 KN-COSM-BACA	Battery Operated, Ion Smoke/CO Combo
NEW CP9000CA	CP9000CA KN-COPE-DCA	Battery Operated, Photo Smoke/CO Combo



220



CP9000CA

Model Selection Table:

ITEM#	BRAND	SMOKE SENSOR	POWER SOURCE	SPECIAL FEATURES
220	Kidde	Ionization	AA	Voice Warning, Peak Level Memory, Front-Load Battery
CP9000CA	Kidde	Photoelectric	9V	Voice Warning, Peak Level Memory, Front-Load Battery

SMOKE/CO COMBINATION ALARMS CONTINUED

Hardwired AC Operated

Combination alarms offer protection from two deadly threats in one unit. Many models offer an exclusive voice warning system that eliminates confusion and clearly warns you and your family of a fire or carbon monoxide danger. Combo alarms can save space, and you'll only need to change and test batteries in one device rather than two. Alarms can be wired into an existing interconnected system. Most models also include battery backup and some even provide 10-year sealed lithium battery backup.

PART#	MFG/MODEL#	DESCRIPTION
133	900-0133 KN-COSM-ICA	120V Hardwire, Ion Smoke/CO Combo
SC9126TCA		120V Hardwire, Ion Smoke/CO Combo
119A	900-0119A KN-COSM-IBACA	120V Hardwire, Ion Smoke/CO Combo, Battery Backup
SC9126BTCA		120V Hardwire, Ion Smoke/CO Combo, Battery Backup
I12010S-CO-CA	I12010S-CO-CA i12010SCOCA	120V Hardwire, 10 Year, Ion Smoke/CO Combo, Battery Backup
900-0213CA	900-0213CA KN-COPE-ICA	120V Hardwire, Photo Smoke/CO Combo, Battery Backup
SC7016BTCA		120V Hardwire, Photo Smoke/CO Combo, Battery Backup
NEW P4010ACLEDSOCA	P4010ACLEDSOCA	120V Hardwire, 10 Year, Photo Smoke/CO & Strobe Combo, Battery Backup
NEW SC9120LBLA		120V Hardwire, 10 Year, Ion Smoke/CO Combo, Battery Backup





Model Selection Table:

ITEM#	BRAND	SMOKE SENSOR	BATTERY BACKUP	POWER SOURCE	INTERCONNECT	SPECIAL FEATURES
133	Kidde	Ionization	None	120V AC	Max 24 Units, 18 Initiating	
SC9126TCA	BRK	Ionization	None	120V AC	Max 18 Units, 12 Initiating	Alarm Locate, Zero Waste
119A	Kidde	Ionization	AA	120V AC with Battery Backup	Max 24 Units, 18 Initiating	Voice Warning, Peak Level Memory, Front-Load Battery
SC9126BTCA	BRK	Ionization	9V	120V AC with Battery Backup	Max 18 Units, 12 Initiating	Alarm Locate, Zero Waste
I12010S-CO-CA	Kidde	Ionization	10 Year Lithium	120V AC with 10 Year Lithium	Max 24 Units, 18 Initiating	Voice Warning
900-0213CA	Kidde	Photoelectric	9V	120V AC with Battery Backup	Max 24 Units, 18 Initiating	Voice Warning, Peak Level Memory, Front-Load Battery
SC7016BTCA	BRK	Photoelectric	AA	120V AC with Battery Backup	Max 18 Units, 12 Initiating	Alarm Locate, Zero Waste
P4010ACLEDSOCA	Kidde	Photoelectric	10 Year Lithium	120V AC with 10 Year Lithium	Max 24 Units, 18 Initiating	Voice Warning
SC9120LBLA	BRK	Photoelectric	10 Year Lithium	120V AC with 10 Year Lithium	Max 18 Units, 12 Initiating	Alarm Locate

SMOKE/CO COMBINATION ALARMS CONTINUED

Wireless Interconnect

Kidde and **BRK** offer a series of smoke and combination smoke & carbon monoxide alarms that can be interconnected wirelessly. The **Kidde** alarms are powered by sealed, 10-year lithium batteries and have voice notifications to which helps you to better understand the status of the unit.

PART#	MFG/MODEL#	DESCRIPTION
 P4010ACSCO-WCA	P4010ACSCO-WCA	Wireless 120V Hardwire, Photo Smoke/CO Combo, 10 Year, Battery Backup
 P4010DCSCO-WCA	P4010DCSCO-WCA	Wireless Battery Operated, 10 Year, Photo Smoke
SCO500NVA		Wireless Battery Operated, Photo Smoke/CO Combo







Model Selection Table:

ITEM#	BRAND	SMOKE SENSOR	POWER SOURCE	INTERCONNECT	SPECIAL FEATURES
P4010ACSCO-WCA	Kidde	Photoelectric	120V AC with 10 Year Lithium	Max 24 Wireless Units	Alarm Locate, Voice Warning
P4010DCSCO-WCA	Kidde	Photoelectric	10 Year Lithium	Max 24 Wireless Units	Alarm Locate, Voice Warning
SCO500NVA	BRK	Photoelectric	AA	Max 18 Wireless Units	Alarm Locate

WIRELESS INTERCONNECT

Kidde Wireless Interconnect

For home residential use. Wireless or hardwire interconnect triggers each connected alarm in the network to sound once smoke is detected. This can provide more time to react. Existing networks of interconnected alarms can be expanded with use of a single P4010ACS-WCA and additional Kidde Wireless alarms.

PART#	MFG/MODEL#	DESCRIPTION
201WA	900-0201-003 RF-SM-DC-CA	Wireless, Battery Operated, Ion Smoke
 P4010DCS-WCA		Wireless, Battery Operated, 10 Year, Photo Smoke
 P4010ACS-WCA	P4010ACS-WCA	Wireless, 120V Hardwire, Photo Smoke, 10 Year, Battery Backup
 P4010ACSCO-WCA	P4010ACSCO-WCA	Wireless, 120V Hardwire, Photo Smoke/CO Combo, 10 Year, Battery Backup
 P4010DCSCO-WCA	P4010DCSCO-WCA	Wireless, Battery Operated, 10 Year, Photo Smoke



Model Selection Table:

ALARM	ITEM#	BRAND	SMOKE SENSOR	POWER SOURCE	INTERCONNECT	SPECIAL FEATURES
Smoke	201WA	Kidde	Ionization	AA	Max 12 Wireless Units	
	P4010DCS-WCA	Kidde	Photoelectric	10 Year Lithium	Max 24 Wireless Units	Alarm Locate, Voice Warning
	P4010ACS-WCA	Kidde	Photoelectric	120V AC with 10 Year Lithium	Max 24 Wireless Units	Alarm Locate, Voice Warning
SMOKE/CO	P4010ACSCO-WCA	Kidde	Photoelectric	120V AC with 10 Year Lithium	Max 24 Wireless Units	Alarm Locate, Voice Warning
	P4010DCSCO-WCA	Kidde	Photoelectric	10 Year Lithium	Max 24 Wireless Units	Alarm Locate, Voice Warning

WIRELESS INTERCONNECT CONTINUED

BRK OneLink Wireless Interconnect

For home residential use. OneLink Wireless Alarms communicate with each other. When one sounds they all sound. Replace any existing hardwired alarm with the SA520CNA "Bridge Unit" Smoke Alarm and the wirelessly connect up to 18 OneLink battery alarms with no additional wiring. Models feature a single button test/silence and alarm latch to identify initiating alarms.

PART#	DESCRIPTION
SA500CNA	Wireless, Battery Operated, Photo Smoke
SA520CNA	Wireless, 120V Hardwire, Photo Smoke, Battery Backup "Bridge Unit"
CO500A	Wireless, Battery Operated, CO Alarm
SCO500NVA	Wireless, Battery Operated, Photo Smoke/CO Combo



SA500CNA



SA520CNA



SCO500NVA

Model Selection Table:

ALARM	ITEM#	BRAND	SMOKE SENSOR	POWER SOURCE	INTERCONNECT	SPECIAL FEATURES
Smoke	SA500CNA	BRK	Photoelectric	AA	Max 18 Wireless Units	Alarm Locate
	SA520CNA	BRK	Photoelectric	120V AC with Battery Backup	Max 18 Wireless Units	Alarm Locate
CO	CO500A	BRK		AA	Max 18 Wireless Units	Alarm Locate
SMOKE/CO	SCO500NVA	BRK	Photoelectric	AA	Max 18 Wireless Units	Alarm Locate

ALARM RELAY MODULES & ALARM ADAPTORS

The **Kidde 120X** can be used to activate auxiliary warning devices such as external bells and sirens, hallway or stairway lighting. This relay will only activate when it receives a smoke signal from an interconnect Smoke Alarm.

The **Kidde CO120X** can be used to activate auxiliary warning devices such as external bells and sirens, hallway or stairway lighting. This relay will only activate when it receives a CO signal from an interconnect Carbon Monoxide Alarm.

The **BRK RM4** works with **BRK** Smoke and Heat Alarms and Smart interconnect CO alarms. This 120V AC Auxiliary Relay features form-C contacts that switch between normally open and closed contacts.

The **BRK ADK-12** adapter plug allows you to easily connect competitive alarms without rewiring. **For use with Kidde smoke alarms.**

PART#	DESCRIPTION
120X	Smoke Alarm Aux. Relay Module, Kidde
CO120X	CO Aux. Relay Module, Kidde
RM4	Smoke, CO & Heat Alarms Aux. Relay, BRK
ADK-12	Adapter Plug to Connect BRK to Kidde Alarms



120X



CO12X

PULL STATION PROTECTORS

Stopper II Indoor Use

Stopper II Models for Indoor Use consist of a clear, tamperproof, tough polycarbonate shield and frame, but the line includes models with the option of a piezo horn and spacer. The cover accommodates most manual pull stations.



- ULC Listed to Canadian safety standards (for standard and custom labeling)
- Typical working properties of polycarbonate are -40° to 250°F (-40° to 121°C)
- Optional horn has a choice of 95 or 105 dB self-contained alarm (includes 9V battery)
- Standard red units have "In Case of Fire..." label unless specified with "no label" or "custom label" (extra charge for custom label)
- Horn housing is available in red, blue, green or yellow with optional custom labeling

PART#	DESCRIPTION
STI1100	Stopper II with Horn, Flush Mount
STI1130	Stopper II with Horn and Spacer, Surface Mount
STI1130FRE	Stopper II with Horn and Spacer, Surface Mount, French
STI1200	Stopper II without Horn, Flush Mount
STI1200FRE	Stopper II without Horn, Flush Mount, French
STI1230	Stopper II without Horn, with Spacer, Surface Mount
STI3100	Conduit Spacer, Clear for Stopper II & Weather Stopper



ATTRIBUTE	SPECIFICATION			
Item#	STI1100	STI1130	STI1200	STI1230
Listing	ULC	ULC	ULC	ULC
Power Source	9V	9V	None	None
Mounting Option	Flush Mnt	Surface Mnt	Flush Mnt	Surface Mnt
Horn	Horn	Horn	No Horn	No Horn
Colour	Red Housing	Red Housing	Red Housing	Red Housing
Width (In.)	7.2	7.2	7.2	7.2
Height (In.)	10.2	10.2	10.2	10.2
Depth (In.)	3.3	5.5	3.3	5.5

Stopper II Weather Stopper Indoor/Outdoor Use

The Stopper II Weather Stopper consists of a clear, tamperproof, tough polycarbonate shield and gasketed frame, but the line includes models with the option of a piezo horn and spacer. The cover accommodates most manual pull stations.

- Weather model have closed cell gaskets
- ULC Listed to Canadian safety standards (for standard and custom labeling)
- Typical working properties of polycarbonate are -40° to 250°F (-40° to 121°C)
- Fits virtually all manual pull stations
- Standard red units have "In Case of Fire..." label unless specified with "no label" or "custom label" (extra charge for custom label)
- Horn housing is available in red, blue, green or yellow with optional custom labeling

PART#	DESCRIPTION
STI1250	Stopper II without Horn, Flush Mount, Red
STI3150	Stopper II without Horn, with Spacer, Surface Mount
STI3100	Conduit Spacer, Clear for Stopper II & Weather Stopper

ATTRIBUTE	SPECIFICATION	
Item#	STI1250	STI3150
Listing	ULC	ULC
Mounting Option	Flush Mnt	Surface Mnt
Horn	No Horn	No Horn
Colour	Red Housing	Red Housing
Width (In.)	7.2	7.2
Height (In.)	10.2	10.2
Depth (In.)	3.3	5.5



CATO Protective Covers

CATO PROTECTIVE COVERS are injection molded of high density plastic and come with scored break glass and breaker bar. These covers are water resistant for outside installation, has UL HB94 Burn Rating, come from fully assembled with mounting screws and anchors provided, and can be installed in a very few minutes.

PART#	DESCRIPTION
220SB	Pull Station Cover w/Breaker Bar, Surface Mount
22020	Replacement Plastic Break Panel
220S	Pull Station Cover w/Pull-Down Cover, Surface Mount
220R	Pull Station Cover w/Pull-Down Cover, Recessed Mount



ATTRIBUTE	SPECIFICATION		
Item#	220SB	220S	220R
Style	Surface Mnt	Surface Mnt	Recessed Mnt
Colour	Red	Red	Red
Width (In.)	7½"	7½"	7½"
Height (In.)	8¼"	8¼"	8¼"
Depth (In.)	3¾"	3¾"	2¼"

UNIVERSAL STOPPER PRODUCTS

Universal Stopper Indoor/Outdoor Use

These indoor/outdoor low profile or dome polycarbonate covers protect devices such as dual action pull stations, keypads for entry systems, intercom stations, emergency buttons, electrical light switches, duplex plugs, etc., without restricting legitimate operation.

Cover options: dome or low profile, with or without horn, flush mount, surface mount or waterproof back box models. Maximum protrusion is 4 inches deep.

- ULC Listed to Canadian safety standards (for standard and custom labeling)
- Typical working properties of polycarbonate are -40° to 250°F (-40° to 121°C)
- Sized to fit most pull stations
- Red units "In Case of Fire..." label
- Gaskets included

PART#	DESCRIPTION
STI13000NC	Universal Stopper w/out Horn, Flush Mount, No Label, Clear
STI13010FR	Universal Stopper w/out Horn, Flush Mount
STI13020FR	Universal Stopper with Horn, Flush Mount
STI13210FR	Universal Stopper w/out Horn, Surface Mount
STI13220FR	Universal Stopper with Horn, Surface Mount
STI13310FR	Universal Stopper w/out Horn, Enclosed Flush Backbox
STI13410FR	Universal Stopper w/out Horn, Enclosed Flush Backbox & Sealed Mounting Plate



ATTRIBUTE	SPECIFICATION						
Item#	STI13000NC	STI13010FR	STI13020FR	STI13210FR	STI13220FR	STI13310FR	STI13410FR
Replaces Item#	STI6500	STI6525	STI6600	STI6535	STI6605	N/A	N/A
Cover	Dome	Dome	Dome	Dome	Dome	Dome	Dome
Mounting Option	Flush Mnt	Flush Mnt	Flush Mnt	Surface Mnt	Surface Mnt	Enclosed Flush Backbox	Enclosed Flush Backbox & Sealed Mounting Plate
Horn	No Horn	No Horn	Horn	No Horn	Horn	No Horn	No Horn
Housing/Horn Colour & Label	No Label, Clear	Red Fire Label	Red Fire Label	Red Fire Label	Red Fire Label	Red Fire Label	Red Fire Label
Listing	ULC	ULC	ULC	ULC	ULC	ULC	ULC
Width (In.)	5.4	5.4	5.4	5.4	5.4	5.4	5.4
Height (In.)	8.15	8.15	8.15	8.15	8.15	8.15	8.15
Depth (In.)	2.66	2.66	2.66	4	4	2.8	4

HORN/STROBE/BEACON COVERS

Horn/Strobe/Speaker Damage Stopper

Here are excellent ways to protect strobe units against both vandalism and accidental damage. Constructed of tough, 9-gauge steel wire coated with corrosion resistant red or white polyester, these guards can take hard knocks in stride.

PART#	DESCRIPTION
STI9708	Horn/Strobe Wire Guard Surface Mount, White



STI9708

ATTRIBUTE	SPECIFICATION
Item#	STI9708
Style	Surface Mnt
Listing	ULC
Material	9-gauge coated steel wire
Colour	White
Width (In.)	6.74
Height (In.)	7.49
Depth (In.)	6.09

Strobe Damage Stopper

These virtually indestructible covers (solid for strobe-only alarms) are designed to stop vandalism and accidental damage. Molded of clear, thick, UV-stabilized polycarbonate material. Various back box and spacer depths are available to accommodate special applications. Unique Enviro Kits are available for extreme conditions where dampness or water is present.

PART#	DESCRIPTION
STI1221E	Strobe Damage Stopper w/Open Bkx for FI Mt



STI1221E

ATTRIBUTE	SPECIFICATION
Item#	STI1221E
Style	Strobe Only
Mounting Option	Open Bkx For Flush Mnt
Listing	ULC
Material	Polycarbonate
Colour	Clear
Width (In.)	6.5
Height (In.)	8.5
Depth (In.)	4

Stopper Dome

This super tough cover is designed to provide maximum protection against physical damage (both accidental and intentional), dust, grime and damage from severe environments indoors and out.

PART#	DESCRIPTION
STI1225	Stopper Dome for Strobe, FI Mt
STI1227	Stopper Dome for Strobe w/Open Bkx

ATTRIBUTE	SPECIFICATION	
Item#	STI1225	STI1227
Style	Strobe Only	Strobe Only
Mounting Option	Flush Mnt	Surface Mnt, Open Bkx
Listing	ULC	ULC
Material	Polycarbonate	Polycarbonate
Colour	Clear	Clear
Width (In.)	7.37	7.37
Height (In.)	7.37	7.37
Depth (In.)	2.87	4.5



STI1225



STI1227

Smoke Detector Damage Stopper

Easy to install polycarbonate covers help assure smoke detectors will remain operational where vandalism and accidental damage are causing false fire alarms or high maintenance costs. They are offered in clear, black or white polycarbonate.

PART#	DESCRIPTION
STI8100	Smoke Detector Damage Stopper, FI Mt - Clear
STI8130	Smoke Detector Damage Stopper w/Conduit Spacer - Clear



STI8100

ATTRIBUTE	SPECIFICATION	
Item#	STI8100	STI8130
Mounting Option	Flush Mnt	Surface Mnt
Listing	UL, FM	UL
Material	Polycarbonate	Polycarbonate
Colour	Clear	Clear
Width (In.)	8.25	8.25
Height (In.)	8.25	8.25
Depth (In.)	3.75	5.75

Steel Web Stopper for Smoke Detectors

STI borrowed from nature's master builder, the spider, to create a web of protection from vandalism and accidental damage with these UL Listed wire guards. They are constructed of 9-gauge steel wire with corrosion resistant polyester coating or 9-gauge stainless steel wire. Together, they cover virtually every smoke detector model available today.

PART#	DESCRIPTION
STI9601	Steel Web Stopper, Low Profile, FI Mt
STI9604	Steel Web Stopper for Mini Smoke Detectors, FI Mt
STI9605	Steel Web Stopper for Mini Smoke Detectors, Surface Mt
STI9609	Steel Web Stopper, High Profile, FI Mt
STI9610	Steel Web Stopper, High Profile, Surface Mt



STI9601



STI9604



STI9605

ATTRIBUTE	SPECIFICATION				
Item#	STI9601	STI9604	STI9605	STI9609	STI9610
Style	Low Profile	For Mini Detectors	For Mini Detectors	High Profile	High Profile
Mounting Option	Flush Mnt	Flush Mnt	Surface Mnt	Flush Mnt	Surface Mnt
Listing	UL, MEA Approved	UL, MEA Approved	UL, MEA Approved	UL, MEA Approved	UL, MEA Approved
Material	Polycarbonate	Polycarbonate	Polycarbonate	Polycarbonate	Polycarbonate
Colour	White	White	White	White	White
Width (In.)	8.25	7	7.125	8.25	8.25
Height (In.)	8.25	7	7.125	8.25	8.25
Depth (In.)	2.75	3.25	4.5	4.6	6



STI9609

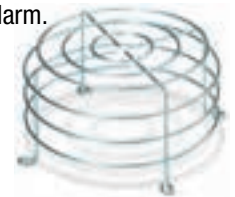


STI9610

SMOKE ALARM GUARD

SMOKE ALARM GUARD for protection against vandalism and theft. Prohibits battery removal, which would disable the smoke alarm.

PART#	DESCRIPTION
SDG	Smoke Alarm Guard 3 $\frac{5}{8}$ " H x 7 $\frac{5}{8}$ " Dia.



SDG

FIRE ALARM INSPECTION, TESTING AND MAINTENANCE PRODUCTS

FIRE ALARM SERVICE LABELS

FIRE ALARM SERVICE LABELS provide a service record for customer and local authorities. Labels can be used for inspection or verifications. Available as a blank label or custom label printed with your company name and phone number. Three roll minimum for custom labels. Priced and Sold per roll of 100. 3½" x 1¾".

PART#	DESCRIPTION
FASL	Fire Alarm Blank Label, 100/Roll, 1 roll min
CUFASL	Fire Alarm Blank Label, 100/Roll, 3 roll min

FIRE ALARM TEST RECORD ESSAI D'ALARME INCENDIE	
REPORT/RAPPORT #:	
PER/SELOM CAN/ULC S53	
CUSTOM LABEL YOUR NAME & PHONE # HERE	
SERVICED BY:	
SERVICE PAR:	
EXPIRES IN 12 MONTHS FROM DATE PUNCHED EXPIREZ DANS 12 MOIS DE LA DATE PERCEE	

BLANK FASL 3½ X 1¾

DETECTOR TEST AEROSOLS

HSI FIRE's SmokeCheck® Smoke Detector Tester (MFG# 25S) is ULC Listed and contains about 150 tests per can. Can be used to test both photoelectric and ionization detectors. Non-toxic and environmentally safe. For high, hard to reach alarms try our N30 with N59. 1490 Adapter Tube improves aim & accuracy in turbulent air conditions.

Note: A total of 5 N59 poles can be combined to reach a maximum height of 34 ft.



PART#	DESCRIPTION
SDT	Smoke Detector Tester - 2.5 oz (25S)
N30	30" Grip & Trigger (use with N59)
N59	59" Aerosol Extension Pole (use with N30)
1490	"Smoking Gun" Test Adapter with 18" Extension



1490 / N59 / N30



SDT



SABRE

SABRE Smoke Detector Tester is for handheld testing and features:

- ULC Listed
- Detector manufacturer endorsed
- More tests per can
- Fast detector activation and clearing
- The end of harmful residue - risk is designed out with the SABRE
- Silicone free
- Eco-responsibility - 100% bio-degradable SABRE, ozone friendly, no CFCs and low GWP
- 300 tests per can

PART#	DESCRIPTION
SABRE	3 oz HandHeld Smoke Detector Tester

SOLOA10 Smoke Detector Tester is designed to be used handheld or in an aerosol dispenser like the **SOLO330**. This tester is non-flammable, non-toxic, silicone free, and leaves no harmful residue on the tested smoke detectors. Conforms to new global aerosol regulations. 500 tests per can. **Replaces SOLOA4.**



SOLOA10



PART#	DESCRIPTION
SOLOA10	4.8 oz Smoke Detector Tester

SMOKE CENTURION Smoke Detector Tester (M8) checks the functionality of smoke detectors. Designed to be used handheld or in an aerosol dispenser like the **SOLO330**. 250-300 tests per can.

- ULC Listed
- Formula approved by leading detector manufacturers
- Either hand-held or with use with SOLO330/332
- Silicone free testing, reduces risk of detector contamination
- Fast detector activation and clearing
- High eco responsibility: ozone friendly (no CFCs) and low GWP propellant

PART#	DESCRIPTION
M8	2.6 oz Centurion Aerosol Smoke Detector Tester



M8

DETECTOR TEST AEROSOLS CONTINUED

SOLOC6 Carbon Monoxide Test Aerosol is designed to be used handheld or in an aerosol dispenser like the **SOLO330**. It is manufacturer approved. The UL Listed **SOLOC6** introduces REAL CO to the sensing cell of the detector. SOLOC6 can be used either as handheld or with the **SOLO330/332** dispenser. The procedure takes no longer than one minute for each detector and is easily carried out using the TEST MODE setting within the detector.

PART#	DESCRIPTION
SOLOC6	Canned CO for Handheld Use or with SOLO330/332



SOLOC6

SOLO 330 Aerosol Dispenser is designed to fit the widest range of detectors and is backed by a limited lifetime warranty. Solo 332 is also available for extra-large detector sizes.

- For use with **SOLOA10** and **SOLOC6**
- Universal design suits widest range of detectors (up to 4" / 100mm in diameter)
- Spring-loaded solution for suspended ceilings
- Transparent test cup for clear view of detector LED
- Detector manufacturer approved
- Solo 332 suitable for detectors up to 7" / 177mm in diameter

PART#	DESCRIPTION
SOLO330	Aerosol Dispenser ULC Listed for use with SOLO10 and SOLOC6
SOLO332	Aerosol Dispenser for larger detectors up to 7" / 177mm in Dia.



SOLO330

SMOKE400 Sensitivity Aerosol is to be used with the TruTest 801 to test the detector sensitivity of ionization or photoelectric smoke detectors. UL Listed, Non-Flammable.

PART#	DESCRIPTION
SMOKE400	9.5 oz TruTest Sensitivity Aerosol



SMOKE400

DETECTOR REMOVAL AND CLEANING

BlowOut hand-held Air Duster is perfect for use with fire alarm equipment. Over time, dirt and debris can build up on a detector and decrease its sensitivity. BlowOut comes complete with a directional straw allowing access to hard to reach areas and is available in a large 10 oz can. No CFC's and Silicone free.

PART#	DESCRIPTION
BLOWOUT	10 oz Detector Duster (canned air)

NEW



BLOWOUT

SOLO DETECTOR DUSTER is ideal to assist with the cleaning of detectors from debris that can collect on detector surfaces which can cause false alarms or failure to alarm in a fire situation.

PART#	DESCRIPTION
SOLOA7	10.7 oz cans duster, canned air non flammable

SOLOA7



AIR BLAST 2000® canned air is non-flammable, non-residual, nonabrasive, with zero ozone depletion potential. Air Blast is moisture free and delivers up to 96 lb. per square inch of pressure. Great for cleaning smoke alarms, panels, and office equipment.

PART#	DESCRIPTION
AB2000	Air Blast 2000 (10 oz)

AB2000



ALARM COMPONENT TESTING

dbCHECKER sound level meter is ideal for testing audible appliances for the public operation mode of an emergency voice / alarm system in accordance with manufacturer's instructions. Meets requirements of NFPA 72 by meeting ANSI S1.4 Type 2 requirements. 32dB to 130 dB at frequencies between 31.5 Hz and 8 Hz.



DB02

PART#	DESCRIPTION
DB02	Sound Level Meter

AIR VELOCITY CHECKER is the ideal device for annual testing to ensure that the duct detector will sample the air velocity as required by NFPA 72 (10.4.2.14g (4)), CAN/ULC 5536-04 (5.7.4.4.1), and according to manufacturer's instructions. Portable, lightweight, battery operated device. Includes hard case.



AV02

PART#	DESCRIPTION
AV02	Air Velocity Test Tool

DUCTCHECKER test tool is the ideal device for annual testing to ensure that the duct detector will sample the airstreams properly as required by NFPA 72 Chapter 10 (10.4.2.2 14 g(4)) and according to manufacturer's instructions. Includes hard case and sampling tube plugs. Meets CAN/ULC S536-04, 5.7.4.4.1.



DUCTCHECKER

PART#	DESCRIPTION
DUCTCHECKER	Duct Detector Test Tool

SOLO ACCESS POLES

SOLO ACCESS POLES are made of fiberglass and are designed for use in servicing fire detectors and can be combined to service heights up to 30+ feet. Made from lightweight, non-conductive fiberglass, suitable for use near electronics with all SOLO products. Lifetime warranty.

PART#	DESCRIPTION
SOLO100	Telescopic Pole extends from 4.8 ft to 14.9 ft allowing access to detectors fitted up to 20 ft
SOLO101	Extension Pole 3.9 ft – Up to 3 can be used to extend the SOLO100 to access 30 ft
SOLO108	Telescopic pole extends to 8ft allowing reach up to 13 ft



SOLO100

SOLO108

HEAT DETECTOR TESTING

- Battery powered - no hanging wires / tangled cables
- Lightweight and simple to use
- Suits fixed temperature, rate-of-rise and combination detectors up to 194°F / 90°C
- Unique IR activation & Cross Air Technology for optimum energy use and results

- Universal design suits widest range of detectors
- Adjustment lever for angled surfaces
- Transparent test cup for clear view of detector LED
- Includes 2 Slim NiMH battery batons and charger for rapid charging

PART#	DESCRIPTION
SOLO460	Heat Detector Tester
SOLO461	Heat Detector Test Kit (460, 760(2), 726)
SOLO760	Replacement Battery Baton (1 baton)
SOLO726	Replacement Battery Charger



1 x SOLO461

1 x SOLO726

2 x SOLO760



SOLO460

DETECTOR TEST KITS

TEST KIT SELECTION GUIDE

SOLO MODEL#	SMOKE TESTING	HEAT TESTING	CO TESTING	ACCESS HEIGHT (APPROX. MAX)	DETECTOR REMOVAL	CARRYING CASE	SENSITIVITY TESTING	BATTERY CHECKER	DB CHECKER	DUCT CHECKER
808	•		•	12 ft		•				
809	•		•	20 ft		•				
810	•		•	10 ft		•				
851	•	•	•	24 ft	•	•				
823	•	•	•	30 ft	•	•				
ST1KIT	•	•	•	30 ft	•	•	•	•		
ST2KIT	•	•	•	30 ft	•	•	•	•	•	•

SOLO 808 STARTER KIT

- 1 x Solo 108 13 ft Access Pole
- 12 x Smoke Centurion Aerosols (M8)
- 1 x Solo 330 Aerosol Dispenser
- 1 x Solo 604 Carrying Bag

SOLO 809 STARTER KIT

- 1 x Solo 100 15 ft Access Pole
- 12 x Smoke Centurion Aerosols (M8)
- 1 x Solo 330 Aerosol Dispenser
- 1 x Solo 604 Carrying Bag

SOLO 810 STARTER KIT

- 1 x Solo 101 4 ft Access Pole
- 12 x Smoke Centurion Aerosols (M8)
- 1 x Solo 330 Aerosol Dispenser
- 1 x Solo 604 Carrying Bag

SOLO 851 TECHNICIAN KIT

- 1 x Solo 100 15 ft Access Pole
- 1 x Solo 460 Heat Detector Tester
- 1 x Solo 101 4 ft Extension Pole
- 1 x Solo 610 Carrying Bag
- 1 x Solo 200 Universal Removal Tool
- 1 x Solo 725 Battery Charger
- 1 x Solo 330 Aerosol Dispenser
- 2 x Solo 760 Battery Batons

SOLO 823 ENHANCED TECHNICIAN KIT

- 1 x Solo 100 15 ft Access Pole
- 1 x Solo 460 Heat Detector Tester
- 3 x Solo 101 4 ft Extension Pole
- 1 x Solo 610 Carrying Bag
- 1 x Solo 200 Universal Removal Tool
- 1 x Solo 725 Battery Charger
- 1 x Solo 330 Aerosol Dispenser
- 2 x Solo 760 Battery Batons

PART#	DESCRIPTION
NEW SOL0808	Starter Kit 12 ft (108, 330, 604, 12-M8)
SOL0809	Starter Kit 20 ft (100, 330, 604, 12-M8)
SOL0810	Starter Kit 9 ft (101, 330, 604, 12-M8)
SOL0851	Smoke/Heat/CO Test Kit 24 ft (100, 101, 200, 330, 461, 610)
SOL0823	Smoke/Heat/CO Test Kit 30 ft (100, 3-101, 200, 330, 461, 610)



SOL0808



SOL0809



SOL0851



SOL0823

MULTICRITERIA DETECTOR TESTING



TESTIFIRE is the world's first multi-stimulus detector tester for smoke, heat and CO fire detectors.

Uniquely capable of producing smoke, heat and CO stimuli, Testifire enables tests of fire detector sensors to be conducted independently, sequentially or simultaneously. Equally suitable for single or multi-sensor, point or aspirating fire detectors, Testifire is the most advanced fire detector tester available today. **IT ENABLES FASTER AND MORE EFFICIENT TESTING OF BOTH SINGLE AND MULTI-SENSOR DETECTORS.** There are two models available - Testifire 1000 for testing smoke and heat and Testifire 2000 for testing smoke, heat and CO. Testifire is UL certified and is approved by leading detector manufacturers from around the world. Each unit is fully programmable to carry out single, simultaneous or combined test cycles. Designed to be used with SOLO poles.

TESTIFIRE 1001 Smoke and Heat Detector Tester includes:

- Testifire 1000 Head Unit
- 1x Smoke Capsule
- 2 x Solo 760 Battery Batons and Charger

TESTIFIRE 2001 Smoke, Heat & CO Detector Tester includes:

- Testifire 2000 Head Unit
- 1 x Smoke Capsule and 1 x CO Capsule
- 2 x Solo 760 Battery Batons and Charger



TESTIFIRE Remote Control (TF25)

An optional accessory, the remote control is required only for situations where the IR test beam of Testifire that triggers or stops a test is not broken by a physical presence.

PART#	DESCRIPTION
TF1000	Testifire Smoke / Heat HEAD ONLY
TF1001	Testifire Smoke / Heat w/battery and charger
TF2000	Testifire Smoke / Heat / CO HEAD ONLY
TF2001	Testifire Smoke / Heat / CO w/battery & charger
TF25	Testifire remote control
SOLO760	Replacement Battery Baton (1 baton)
SOLO726	Replacement Battery Charger



TESTIFIRE Smoke Capsules

Replaceable Smoke Capsules for use with Testifire 1000 and 2000 detector testers.

- Smoke Capsules are good for 4-500 tests

TESTIFIRE CO Capsules

Replaceable Carbon Monoxide Capsules for use with Testifire 2000 models only.

- CO capsules are good for 125-150 tests

PART#	DESCRIPTION
TS3	Smoke Capsule (3 pack)
TC3	CO Capsule (3 pack)



MULTICRITERIA DETECTOR TESTING CONTINUED

TEST KIT SELECTION GUIDE

SOLO MODEL#	SMOKE TESTING	HEAT TESTING	CO TESTING	ACCESS HEIGHT (APPROX. MAX)	DETECTOR REMOVAL	CARRYING CASE
TF1851	●	●		24 ft	●	●
TF1823	●	●		30 ft	●	●
TF2851	●	●	●	24 ft	●	●
TF2823	●	●	●	30 ft	●	●

TESTIFIRE 1851 SMOKE & HEAT DETECTOR TESTING KIT

- 1 x Smoke & Heat Detector Tester
- 1 Solo 610 Carrying Bag
- 1 x Solo 100 Access Pole
- 1 x Smoke Capsule
- 1 x Solo 101 Extension Pole
- 2 x Battery Batons
- 1 x Solo 200 Removal Tool
- 1 x Battery Charger



TF1851

TESTIFIRE 2851 SMOKE, HEAT & CO DETECTOR TESTING KIT

- 1 x Smoke, Heat & CO Detector Tester
- 1 x Smoke Capsule*
- 1 x Solo 100 Access Pole
- 1 x CO Capsule*
- 1 x Solo 101 Extension Pole
- 2 x Battery Batons
- 1 x Solo 200 Removal Tool
- 1 x Battery Charger
- 1 x Solo 610 Carrying Bag



TF2851

*1, not a pack of 3

TESTIFIRE 1823 SMOKE & HEAT DETECTOR TESTING KIT

- 1 x Smoke & Heat Detector Tester
- 1 Solo 610 Carrying Bag
- 1 x Solo 100 Access Pole
- 1 x Smoke Capsule
- 3 x Solo 101 Extension Poles
- 2 x Battery Batons
- 1 x Solo 200 Removal Tool
- 1 x Battery Charger



TF1823

TESTIFIRE 2823 SMOKE, HEAT & CO DETECTOR TESTING KIT

- 1 x Smoke, Heat & CO Detector Tester
- 1 x Smoke Capsule*
- 1 x Solo 100 Access Pole
- 1 x CO Capsule*
- 3 x Solo 101 Extension Pole
- 2 x Battery Batons
- 1 x Solo 200 Removal Tool
- 1 x Battery Charger
- 1 x Solo 610 Carrying Bag



TF2823

*1, not a pack of 3

PART#	DESCRIPTION
*TF1851	TF Kit (Solo100, 101, 200, 610, TF1001)
*TF1823	TF Kit (Solo100, 3-101, 200, 610, TF1001)
*TF2851	TF Kit (Solo100, 101, 200, 610, TF2001)
*TF2823	TF Kit (Solo100, 3-101, 200, 610, TF2001)
SOLO760	Replacement Battery Baton (1 baton)
SOLO726	Replacement Battery Charger

* SPECIAL ORDER

DETECTOR SENSITIVITY TESTING



TRUTEST enables fire alarm technicians to measure the sensitivity of installed smoke detectors quickly, accurately, easily, and professionally. A revolutionary product, Trutest not only introduces a smoke test aerosol through the vents of the installed detector to the sensing chamber, but operates using a precision closed loop system - measuring smoke obscuration and feeding back information to a controlling microprocessor. Calibration is required every 12-18 months or 5000 tests whichever comes first. Trutest will not perform anymore tests once it hits 5000 tests. SDi is an authorized UL service centre and provides a calibration service.

TRUTEST 801 SMOKE DETECTOR SENSITIVITY TESTER

- UL Listed
- Reduces false alarms - a huge problem in the industry
- Battery operated and easily portable
- Simple to use
- Suits most detectors - both ionization and photoelectric
- Calibrated and results in % / ft
- Automatically self-calibrates before each test
- Measures actual detector sensitivity
- Self calibrates before testing
- Test detectors in place. No need to remove detector



TRUTEST 800 KIT

- 1 x Trutest 801 Smoke Detector Sensitivity Tester
- 12 x Trutest Smoke 400 Detector Test Aerosol Canisters
- Storage case and pole bag
- 1 x Solo Telescopic Access Pole



SMOKE 400 DETECTOR TEST AEROSOL

- UL Listed
- For use with Trutest 801
- Non-flammable



SMOKE400

PART#	DESCRIPTION
TRUTEST801	Smoke Detector Sensitivity Tester
TT800KIT	TruTest 801, Solo 100 & 12x Smoke 400, Storage case and pole bag
SMOKE400	9.5 oz TruTest Sensitivity Aerosol
TTCALIBRATE	Calibration includes all shipping charges

- **EXIT LIGHTING**
- **EMERGENCY LIGHTING**



CSA Certified
to C22.2
#141.15 and
C860

EXIT AND EMERGENCY LIGHTS

SELF-LUMINOUS TRITIUM EXIT SIGNS

TRITIUM EXIT SIGNS are self-luminous signs that require no power to operate. The EXIT and Running Man signs are ULC listed, vandal resistant, waterproof, explosion proof, and incapable of generating sparks. These single-sided signs come complete with mounting hardware (surface, flag, ceiling, etc.) and tape to block out chevrons as required. A sticker on the unit lets you know when the sign is to be replaced.

- No Batteries
- No Electricity
- Water-proof
- Vandal Resistant
- Non Maintenance
- Explosion Proof
- Operating Temp - 76°F TO +212°F
- Recyclable if returned to Manufacturer

NOTE: Signs are shipped as Dangerous Goods. Extra shipping charges will apply.

ORDERING NOTE: Address where the signs are to be installed is required when ordering per Government Regulations for these signs.



EXIT10GR / EXIT20GR



EXIT10W / EXIT20W



175002-RM



PART#	DESCRIPTION	W	H	TEMP RANGE	# OF FACES	FRAME COLOUR	LEGEND
EXIT10GR	10-Year EXIT, Red w/Grey Frame	12.75"	8.25"	- 76°F TO +212°F	1	Grey	Red
EXIT10W	10-Year EXIT, Red w/White Frame	12.75"	8.25"	- 76°F TO +212°F	1	White	Red
EXIT20GR	20-Year EXIT, Red w/Grey Frame	12.75"	8.25"	- 76°F TO +212°F	1	Grey	Red
EXIT20W	20-Year EXIT, Red w/White Frame	12.75"	8.25"	- 76°F TO +212°F	1	White	Red
175002-RM	10-Year Running Man, Green w/Grey Frame, c/w 3 Directional Face Plates	12.75"	8.25"	- 76°F TO +212°F	1	Grey	Green

PHOTOLUMINESCENT EXIT & RUNNING MAN SIGNS

Suitable for floor proximity installation. Can be used for both high-level and low-level applications.

- Zero energy consumption, zero cost, zero maintenance
- Non-toxic, non-radioactive, no disposal cost
- Movable if egress paths changed
- Visible at 15.25 meters (50 feet) for a minimum of 90 minutes



- Life expectancy: 25+ years
- Explosion-proof

AIMP632AS Series

PART#	DESCRIPTION	W	H
AIMP632AS	Aluminum EXIT, Yellow Text on Red Background, 75 ft Visibility	15¼"	9"



AIMP632AS
(shown with optional black frame)

AIMP631AS Series

PART#	DESCRIPTION	W	H
AIMP631AS	Aluminum SORTIE, Yellow Text on Red Background, 75 ft Visibility	22⅞"	8⅝"



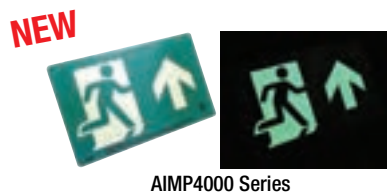
AIMP631AS
(shown with optional black frame)

PHOTOLUMINESCENT EXIT & RUNNING MAN SIGNS CONTINUED



NEW AIMP4000 Series

PART#	DESCRIPTION	W	H
▶ AIMP4343AS	Aluminum RM, Left Arrow 50 ft Visibility	15"	9"
▶ AIMP4344AS	Aluminum RM, Right Arrow 50 ft Visibility	15"	9"
▶ AIMP4973AS	Aluminum RM, Straight Thru 50 ft Visibility	15"	9"
▶ PF4001AS1WBK	Frame, Single Face, Wall Mount, Black		
▶ PF4001AS1CBK	Frame, Single Face, Ceiling Mount, Black		
▶ PF4001AS1EBK	Frame, Double Face, Ceiling Mount, Black		
▶ PF4001AS2EBK	Frame, Double Face, End Mount, Black		
▶ PF4001AS1WSI	Frame, Single Face, Wall Mount, Silver		
▶ PF4001AS1CSI	Frame, Single Face, Ceiling Mount, Silver		
▶ PF4001AS1ESI	Frame, Single Face, End Mount, Silver		
▶ PF4001AS2CSI	Frame, Double Face, Ceiling Mount, Silver		
▶ PF4001AS2ESI	Frame, Double Face, End Mount, Silver		



BATTERY UNITS

WAY2GO LED

AIMLITE's commercial **EBST-2L/EBST12-2L WAY2GO LED SERIES** features a steel battery unit designed to provide efficient and reliable emergency lighting. Utilizing a sturdy all steel housing, our series presents a modern and unobtrusive design. Available in 6VDC 36W with **over 4-hours duration** and 12VDC 72W with **over 8-hours duration**. LED heads for the 6VDC unit are equivalent to 2 x 12W quartz bi-pin lamps, 12VDC LED heads are equivalent to 2 x 20W MR16 lamps.

- Crisp white LEDs with limited lifetime warranty
- Diagnostic/pilot LED
- 3½ ft Line Cord Included
- 20-Gauge steel construction

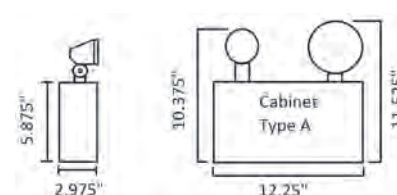
PART#	DESCRIPTION
EBST-2L	6V 36W Battery Unit, WAY2GO
EBST12-2L	12V 72W Battery Unit, WAY2GO



CSA Certified to C22.2 #141.15



EBST-2L / EBST12-2L



PART#	CABINET	W	H	D	VOLTAGE	MAX WATT @ 30 MINS	INPUT VAC	HEADS STYLE	LAMP	BATTERY
EBST-2L	A	12.25	10.375	2.975	6	36	120/347	2 x Par 18	2W LED	1 x 6V5Ah
EBST12-2L	A	12.25	10.375	2.975	12	72	120/347	2 x Par 18	2.5W LED	2 x 6V5Ah

The commercial **EBPC-2L** features a plastic battery unit designed to provide an economical and versatile solution to emergency lighting needs all within a small, compact design. The **EBPC-2L series** is configured with 6VDC output and two **2W LED** heads and can run for 240 minutes duration as a standalone unit.

PART#	DESCRIPTION
EBPC-2L	6V Plastic Battery Unit, 120/347, Way2GO



CSA Certified to C22.2 #141.15



EBPC-2L

We are in the business of growing your business

BATTERY UNITS CONTINUED

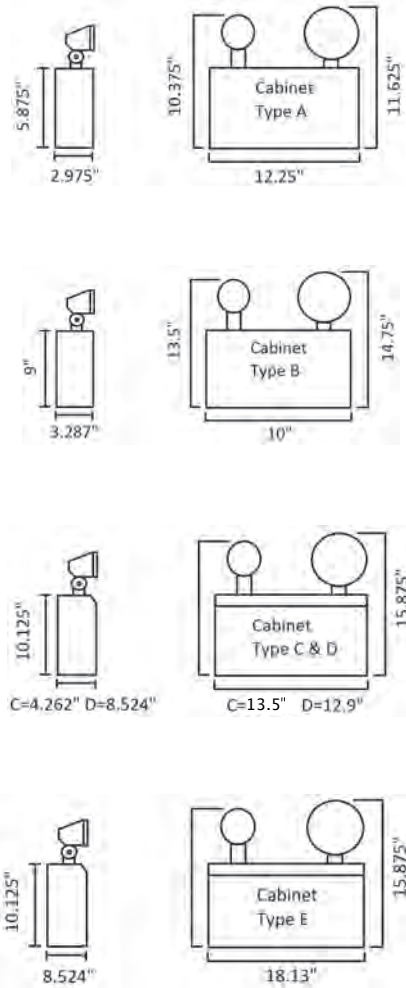


EBST

The **EBST SERIES** of commercial steel battery units is designed to provide efficient and reliable emergency lighting. Utilizing a sturdy, all steel housing, the EBST presents a modern and unobtrusive design. On higher capacity models, the cabinet front is sloped to allow better internal access and superior low angle light distribution. The EBST series is available in 6VDC, 12VDC and 24VDC versions in a range of wattage capacities between 18 and 720W, for 30-minute duration. Standard with 9 Watt Par 18 type heads however a wide range of lamps, including **LED**, and head type, number and placement are available, including MR16. The EBST can also accommodate a wide variety of options, including auto-testing self-diagnostics and remote testing.

3½ ft Line Cord Included.

PART#	DESCRIPTION
EB6362	6V 36W Battery Unit
EB6362HP	6V 36W Battery Unit, High Capacity
EB650-2SM-3LJ	6V 50W Battery Unit, 3W LED
EB6722	6V 72W Battery Unit
EB672-2SM-3LJ	6V 72W Battery Unit, 3W LED
EB61002	6V 100W Battery Unit
EB61602	6V 160W Battery Unit
EB1236-2SM-3LJ	12V 36W Battery Unit, 3W LED
EB12722	12V 72W Battery Unit
EB121002	12V 100W Battery Unit
EB12100-2SM-3LJ	12V 100W Battery Unit, 3W LED
EB121602	12V 160W Battery Unit
EB12160-2SM-3LJ	12V 160W Battery Unit, 3W LED
EB122002	12V 200W Battery Unit
EB12200-2SM-3LJ	12V 200W Battery Unit, 3W LED
EB122502	12V 250W Battery Unit
EB123602	12V 360W Battery Unit
EB241442	24V 144W Battery Unit
EB242002	24V 200W Battery Unit
EB243202	24V 320W Battery Unit
EB243502	24V 350W Battery Unit
EB245502	24V 550W Battery Unit
EB247202	24V 720W Battery Unit
B908	6V, 9W Tungsten Bulb (wedge)



Remote Head Retrofit

PART#	DESCRIPTION
LEME6T024V4WWSP-RV	4W LED for 6 to 24V Units, Wedge Base
LEME6T024V4WBSR-RV	4W LED for 6 to 24V Units, BiPin Base



"A" Cabinet



"B" Cabinet



"C" Cabinet



"D" & "E" Cabinet

Steel Fire 800.387.9555

BATTERY UNITS CONTINUED

PAR 18 Incandescent:

PART#	CABINET	W	H	D	VOLTAGE	MAX WATT @ 30 MINS	BATTERY	INPUT VAC	HEADS STYLE	LAMP
EB6362	A	12.25	10.375	2.975	6	36	1 x 6V5Ah	120/347	2 x Par 18	9W T
EB6362HP	A	12.25	10.375	2.975	6	36	1 x 6V7.2Ah			
EB6722	B	10	13.5	3.287	6	72	1 x 6V12Ah			
EB61002	B	10	13.5	3.287	6	100	2 x 6V7.2Ah			
EB61602	C	14.25	14.625	4.262	6	160	2 x 6V12Ah			
EB12722	A	12.25	10.375	2.975	12	72	2 x 6V5Ah			
EB121002	B	10	13.5	3.287	12	100	1 x 12V7.2Ah			
EB121602	C	14.25	14.625	4.262	12	160	2 x 6V12Ah			
EB122002	C	14.25	14.625	4.262	12	200	2 x 12V7.2Ah			
EB122502	D	12.9	14.625	8.524	12	250	1 x 12V32Ah			
EB123602	D	12.9	14.625	8.524	12	360	1 x 12V35Ah			
EB241442	C	14.25	14.625	4.262	24	144	4 x 6V5Ah			
EB242002	C	14.25	14.625	4.262	24	200	2 x 12V7.2Ah			
EB243202	D	12.9	14.625	8.524	24	320	4 x 6V12Ah			
EB243502	E	18.13	14.625	8.524	24	350	2 x 12V7.2Ah			
EB245502	E	18.13	14.625	8.524	24	550	2 x 12V32Ah			
EB247202	E	18.13	14.625	8.524	24	720	2 x 12V35Ah			

PAR18 LED:

PART#	CABINET	W	H	D	VOLTAGE	MAX WATT @ 30 MINS	BATTERY	INPUT VAC	HEADS STYLE	LAMP
EB650-2SM-3LJ	A	12.25	10.375	2.975	6	50	1 x 6V7.2Ah	120/347	2 x Par 18	3W LED
EB672-2SM-3LJ	B	10	13.5	3.287	6	72	1 x 6V12Ah			
EB1236-2SM-3LJ	A	12.25	10.375	2.975	12	36	2 x 6V5Ah			
EB12100-2SM-3LJ	B	10	13.5	3.287	12	100	1 x 12V7.2Ah			
EB12160-2SM-3LJ	C	14.25	14.625	4.262	12	160	2 x 6V12Ah			
EB12200-2SM-3LJ	C	14.25	14.625	4.262	12	200	2 x 12V7.2Ah			

BATTERY UNITS CONTINUED



BECO Low Profile

Brooks' EMERGENCY LIGHTS feature a low-profile design in a flame-retardant, high-impact thermoplastic housing. Universal mounting (with "EZ" quick connect), push-to-test switch, solid-state charger, low-voltage disconnect, and power-on LED indicator light standard.

- 3-ft line cord included for #1PLG ONLY
- 6VDC
- 120 VAC input ONLY
- Plastic Construction
- 90 minute self-powered

PART#	DESCRIPTION	W	H	D
1PLG	6V 10.8W Battery Unit w/3-ft plug-in cord			
S1HRD	6V 10.8W Battery Unit, 120VAC hardwired only	16¼"	5½"	2⅝"
R2HRD	6V 22W Battery Unit, 120VAC hardwired only			



EBN Deluge

The **EBN SERIES** of battery units is designed to operate in the most extreme environments. The unit, designed using a polycarbonate housing, maintains its sealed interior with a continuous integral gasket. The EBN series is available in 6VDC and 12VDC versions in 36W, 72W, 100W or 130W wattage capacity for a minimum of 30 minutes in emergency mode. Autotest feature is standard.

- Wet Location Battery Unit
- CSA Sanitation Certified to NSF 2
- 6 or 12V MODELS, 36W, 72W, 100W or 130W
- 120/277/347VAC Input



PART#	DESCRIPTION
EBN120364WLRBLK	Wet Loc, 12V 36W, 4W LED, Black

ORDERING GUIDE

SERIES	VOLTAGE	WATTAGE	LAMP SELECTION	HOUSING COLOUR	MANDATORY OPTIONS	OPTIONS
EBN	6 - 6V 12 - 12V	36 - 36 watts Ni-Cd 50 - 50 watts, lead acid 72 - 72 watts, lead acid 100 - 100 watts, lead acid 130 - 130 watts, lead acid	4WLR (All) 5WLA (All) 6WLA (12V only) 7WLA (12V only)	BLK - Black WHT - White	ATD - Autotest	Blank - Standard +10°C to +25°C CW - Cold Weather at -40°C to +40°C* CW1 - Cold Weather at -40°C to +40°C for 347VAC**

* Available only with 6V 36W and 120/277VAC.

** Available only with 36W.

EBWP Weatherproof

The EBWP series of NEMA4X and EEMAC4X rated weatherproof battery units is designed to operate in the most extreme environments. The fully gasketed, reinforced, non-metallic housing features a hinged cover that secures with durable screw locks. The EBWP series is available in 6VDC, 12VDC and 24VDC versions in a range of wattage capacities between 36 and 720W, for 30-minutes duration. Standard with two 9 Watt PAR36 weatherproof heads, however a wide range of head type, number and placement are available.

PART#	DESCRIPTION
EBWP6362	6V 36W Weatherproof Battery Unit



REMOTE HEADS

SERIES	PART#	DESCRIPTION
RMSM LED	RMSM1612V3WLJ	Single, 6VDC to 12VDC operational, PAR18, 3W LED
	RMSM2612V3WLJ	Double, 6VDC to 12VDC operational, PAR18, 3W LED
RMSM Incandescent	RMSM16V9W	Single, 6VDC, PAR18, 9W Tungsten
	RMSM26V9W	Double, 6VDC, PAR18, 9W Tungsten
	RMSM112V9W	Single, 12VDC, PAR18, 9W Tungsten
	RMSM212V9W	Double, 12VDC, PAR18, 9W Tungsten
	RMSM112V18W	Single, 12VDC, PAR18, 18W Tungsten
	RMSM212V18W	Double, 12VDC, PAR18, 18W Tungsten
	RMSM124V9W	Single, 24VDC, PAR18, 9W Tungsten
	RMSM224V9W	Double, 24VDC, PAR18, 9W Tungsten
LED Retrofit Bulbs	LEME6T024V4WWSP-RV	4W LED for 6 to 24V Units, Wedge Base
	LEME6T024V4WBSP-RV	4W LED for 6 to 24V Units, BiPin Base
RMMD Compact	RMMD1624V5WLA	Single, 6VDC to 24VDC operational, MR16, 5W LED
	RMMD2624V5WLA	Double, 6VDC to 24VDC operational, MR16, 5W LED
	RMMD1624V4WLA	Single, 6VDC to 24VDC operational, MR16, 4W LED
	RMMD2624V4WLA	Double, 6VDC to 24VDC operational, MR16, 4W LED
RMMB Decorative	RMMB1624V4WLR	Single, 6VDC to 24VDC operational, MR16, 4W LED
	RMMB2624V4WLR	Double, 6VDC to 24VDC operational, MR16, 4W LED
RMN "Deluge"	RMN26244WLR	Double, 6VDC to 24VDC operational, 4W LED, Wet Location, Anti Vandal
	RMN212246WLA	Double, 12VDC to 24VDC operational, 6W LED, Wet Location, Anti Vandal

AimLite



CSA Certified to C22.2 #141.15



LED - RMSM1



RMSM2 Incandescent



LED - RMSM2



RMMB



LED - RMMB

NEW



RMN

LED COMBINATION UNITS



WAY2GO

The commercial **WAY2GO LED SERIES** steel combos feature a slim profile that prevents light leaks. Easy to install design, available in 6VDC 36W with **over 4-hours duration** and 12VDC 72W with **over 8-hours duration**. LED heads for the 6VDC unit are equivalent to 2 x 12W quartz bi-pin lamps, 12VDC LED heads are equivalent to 2 x 20W MR16 lamps. Available in **RUNNING MAN** and **EXIT** and **SORTIE** styles.

- Crisp white LEDs with limited lifetime warranty
- Diagnostic/pilot LED
- 120/347 VAC input
- 20-Gauge steel construction
- Running Man comes standard with 3 Pictogram legends for direction selection
- EXIT and SORTIE comes Standard with two faces

PART#	DESCRIPTION
CSRP-2L	6V 36W Running Man Combo, WAY2GO
CSRP12-2L	12V 72W Running Man Combo, WAY2GO
CXST-2L	6V 36W EXIT Combo, WAY2GO
CXST12-2L	12V 72W EXIT Combo, WAY2GO
CSST-2L	6V 36W SORTIE Combo, WAY2GO
CSST12-2L	12V 72W SORTIE Combo, WAY2GO



CSRP-2L/CSRP12-2L



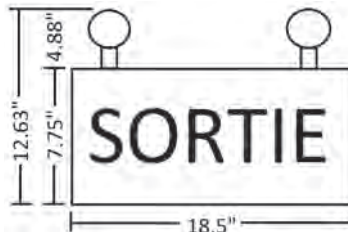
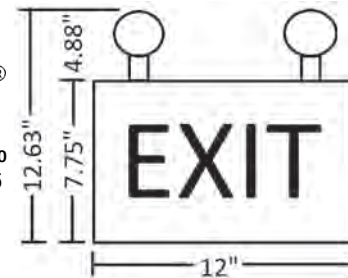
CXST-2L/CXST12-2L



CSST-2L/CSST12-2L



CSA Certified to C22.2 #141.15 and C860



PART#	W	H	D	VOLTAGE	MAX WATT @ 30 MINS	INPUT VAC	# OF FACES	# OF LEGENDS	HEADS STYLE	LAMP	BATTERY
CSRP-2L	12"	12.63"	2.25"	6	36	120/347	Single	3 (Left, Straight, Right)	2 x Par 18	2W LED	1 X 6v5Ah
CSRP12-2L	12"	12.63"	2.25"	12	72	120/347	Single	3 (Left, Straight, Right)	2 x Par 18	2.5W LED	2 x 6V5Ah
CXST-2L	12"	12.63"	2.25"	6	36	120/347	Double	Two	2 x Par 18	2W LED	1 X 6v5Ah
CXST12-2L	12"	12.63"	2.25"	12	72	120/347	Double	Two	2 x Par 18	2.5W LED	2 x 6V5Ah
CSST-2L	18.5"	12.63"	2.25"	6	36	120/347	Double	Two	2 x Par 18	2W LED	1 X 6v5Ah
CSST12-2L	18.5"	12.63"	2.25"	12	72	120/347	Double	Two	2 x Par 18	2.5W LED	2 x 6V5Ah

CSRP

The **CSRP SERIES** of commercial combination steel signs and battery units features a slim profile that eliminates light leaks combined with a simple, easy to install design. Two 9W Tungsten lamp, PAR18 small style, front mounted heads are standard, PAR36 large style or MR16 type are optional.

- Comes standard with 3 Pictogram legends for direction selection
- 6VDC or 12VDC models available
- 36-72 Watt Capacities (30-minute duration)
- Standard with 9W Tungsten PAR18 heads, LED Lamps available
- 120/347 VAC input
- 20-gauge Steel Construction

PART#	DESCRIPTION
CSRP636	6V 36W Running Man Combo
CSRP1272	12V 72W Running Man Combo



CSA Certified to C22.2 #141.15 and C860

PART#	W	H	D	VOLTAGE	MAX WATT @ 30 MINS	INPUT VAC	# OF FACES	# OF LEGENDS	HEADS STYLE	LAMP	BATTERY
CSRP636	12"	12.63"	2.25"	6	36	120/347	Single	3 (Left, Straight, Right)	2 x Par 18	9W T	1 X 6v5Ah
CSRP1272	12"	12.63"	2.25"	12	72	120/347	Single	3 (Left, Straight, Right)	2 x Par 18	9W T	2 x 6V5Ah



CSRP

LED COMBINATION UNITS CONTINUED

CXST-CSST

The **CXST/CSST SERIES** of commercial combination steel signs and battery units features a slim profile that eliminates light leaks combined with a simple, easy to install design. Two 9W Tungsten lamp, PAR18 small style, front mounted heads are standard, PAR36 large style or MR16 type are optional.

- 6VDC or 12VDC models available
- 36-72 Watt Capacities (30-minute duration)
- Standard with 9W Tungsten PAR18 heads, LED Lamps available
- 120/347 VAC input
- Steel Construction
- Standard with two faces

PART#	DESCRIPTION
CXST636	6V 36W EXIT Combo
CXST1236	12V 36W EXIT Combo
CXST1272	12V 72W EXIT Combo
CSST636	6V 36W SORTIE Combo

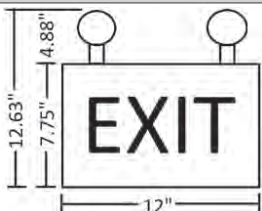


CSA Certified to C22.2 #141.15 and C860

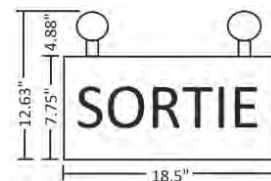
PART#	W	H	D	VOLTAGE	MAX WATT @ 30 MINS	INPUT VAC	# OF FACES	# OF LEGENDS	HEADS STYLE	LAMP	BATTERY
CXST636	12"	12.63"	2.25"	6	36	120/347	Double	Two	2 x Par 18	9W T	1 X 6v5Ah
CXST1236	12"	12.63"	2.25"	12	36	120/347	Double	Two	2 x Par 18	9W T	2 x 6V5Ah
CXST1272	12"	12.63"	2.25"	12	72	120/347	Double	Two	2 x Par 18	9W T	2 x 6V5Ah
CSST636	18.5"	12.63"	2.25"	6	36	120/347	Double	Two	2 x Par 18	9W T	1 X 6v5Ah



CXST



CSST



Brooks Plastic Combo

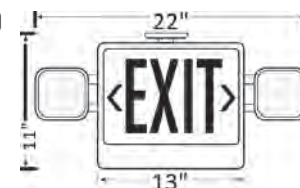
BROOKS' PLASTIC COMBINATION UNIT meets both exit and emergency lighting needs in one economical unit. The unit is NRCAN/C860 Approved, ULC Certified to CSA C22.2 No. 141 and features two adjustable flare free light heads which rotate 180 degrees for maximum field flexibility, pop out chevrons. 120VAC input only.



PART#	DESCRIPTION	BATTERY	W	H	D
LED4	Plastic EXIT Combo	1 X 6v7.2Ah	22"	11"	5"



LED4



CRPN "Deluge" Wet Location

The **CRPN SERIES** of wet location combination running man exit signs is designed to operate in extreme environments. The CRPN series is designed using a polycarbonate housing. The housing features integral wall mounting points and a molded gasket that completely seals the housing from the elements. Standard with 2 heads and Single Face.

- CSA Sanitation certified to NSF 2
- IP RATING 66
- 120/277/347VAC Input

PART#	DESCRIPTION
CRPN060361-24WLR	6V 36W Running Man Wet Location Combo w/ 4W LED MR16 heads

Comes standard (single face) with three pictogram legends for direction selection.



CSA Certified to C22.2 #141.15 and C860 NEMA4X



CRPN

LED EXIT SIGNS



RPST

The clean lines of the **RPST SERIES** of commercial steel signs present a fully modern appearance. The steel provides for a rigid, durable and light-weight sign. Available in AC only, AC/DC and internally self-powered versions.

- LED ultra-bright light source
- Steel Construction
- Running Man comes standard with 3 Pictogram legends for direction selection
- Standard self-powered model provides 90-minutes emergency duration (120-minutes models are available)
- 120/347 VAC input

PART#	DESCRIPTION
RPSTU	LED Running Man, AC/DC Only
RPSTB	LED Running Man, 90-minute Self-powered



PART#	W	H	D	INPUT VAC	DC VOLTAGE	# OF FACES	# OF LEGENDS
RPSTU	12"	7.74"	2.25"	120/347	Universal DC backup voltage from 6 to 24VDC	Single	Three*
RPSTB	12"	7.74"	2.25"	120/347	Self-powered for 90 minutes	Single	Three*



CSA Certified to C22.2 #141.15 and C860



RPST

*Left, Straight, Right.

RPNP

The **RPNP SERIES** of commercial or decorative plastic running man signs is designed using durable and lightweight high impact thermoplastic.

- LED ultra-bright light source
- Plastic Construction
- Running Man comes standard with 3 Pictogram legends for direction selection
- Standard self-powered model provides 90-minutes emergency duration (120-minutes models are available)
- 120/347 VAC input

PART#	DESCRIPTION
RPNPU	Plastic LED Running Man, AC/DC Only
RPNPB	Plastic LED Running Man, 90-minute Self-powered



PART#	W	H	D	INPUT VAC	DC VOLTAGE	# OF FACES	# OF LEGENDS
RPNPU	13 ⁵ / ₈ "	9 ¹ / ₁₆ "	2 ³ / ₁₆ "	120/347	Universal DC backup voltage from 6 to 24VDC	Single	Three*
RPNPB	13 ⁵ / ₈ "	9 ¹ / ₁₆ "	2 ³ / ₁₆ "	120/347	Self-powered for 90 minutes	Single	Three*



CSA Certified to C22.2 #141.15 and C860



RPNP

*Left, Straight, Right.

RPN Deluge

The RPN SERIES of wet location anti vandal running man is designed to operate in extreme environments. The unit, designed using a polycarbonate housing, maintains its sealed interior with a continuous integral gasket. As well, LED pilot light and test switch are sealed type. Available in AC/DC and internally self-powered versions.

Comes standard (single face) with three pictogram legends for direction selection.

Comes standard (double face) with two pictogram legends.

- LED ultra-bright light source
- Steel Construction
- Running Man comes standard with 3 Pictogram legends for direction selection
- Standard self-powered model provides 90-minutes emergency duration (120-minutes models are available)
- 120/347 VAC input

PART#	DESCRIPTION
RPN1BLK-UNVDC	Wet Loc, Running Man, Single Face, AC/DC Only, Black



NEW



RPN

LED EXIT SIGNS CONTINUED



EXST-SXST

The **EXST/SXST SERIES** of commercial steel signs features a slim profile that eliminates light leaks combined with a simple, easy to install design. Available in AC only, AC/DC and internally self-powered versions.

- LED ultra-bright light source
- Steel Construction
- 120/347 VAC input
- EXIT and SORTIE comes Standard with two faces
- Standard self-powered model provides 90-minutes emergency duration (120-minutes models are available)



CSA Certified to C22.2 #141.15 and C860

PART#	DESCRIPTION
EXU	Steel LED EXIT, AC/DC Only
EXB	Steel LED EXIT, 90-minute Self-Powered
SXU	Steel LED SORTIE, AC/DC Only
SXB	Steel LED SORTIE, 90-minute Self-Powered



EXST



SXST

PART#	W	H	D	INPUT VAC	DC VOLTAGE	# OF FACES	# OF LEGENDS
EXU / SXU	12" / 18"	7½"	2¼"	120/347	Universal DC backup voltage from 6 to 24VDC	Double	Two
EXB / SXB	12" / 18"	7½"	2¼"	120/347	Self-powered for 90 minutes	Double	Two

EXPT

The EXPT series of commercial plastic exit signs is designed using durable and lightweight high impact thermoplastic. Signs and canopy quick snap together for speedy installations. Available in AC only, AC/DC and internally self-powered versions.

- LED ultra-bright light source
- Plastic Construction
- 120/347 VAC input
- EXIT comes Standard with two faces
- Standard self-powered model provides 90-minutes emergency duration (120-minutes models are available)



CSA Certified to C22.2 #141.15 and C860

PART#	DESCRIPTION
EXPTU	Plastic LED EXIT, AC/DC Only
EXPTUB	Plastic LED EXIT, 90-minute Self-Powered



EXPT

PART#	W	H	D	INPUT VAC	DC VOLTAGE	# OF FACES	# OF LEGENDS
EXPTU	11 13/16"	7¼"	1 13/16"	120/347	Universal DC backup voltage from 6 to 24VDC	Double	Two
EXPTUB	11 13/16"	7¼"	1 13/16"	120/347	Self-powered for 90 minutes	Double	Two

Brooks Plastic LED Exit Sign

BROOKS' PLASTIC LED EXIT SIGNS are made of high impact thermoplastic. The unit is NRCAN/C860 Approved and ULC Certified to CSA C22.2 No. 141. Directional chevrons/arrows snap out easily. Available in AC/DC and internally Self-Powered versions (90 Minute). Dimensions: 12"W x 7¼"H x 2½"D

120VAC input only.



LEDAC / LED1

PART#	DESCRIPTION
LEDAC	Plastic LED EXIT, AC/DC Only
LED1	Plastic LED EXIT, 90-minute Self-Powered

TEST EQUIPMENT AND LABELS

CUSTOM AND BLANK LIGHTING SERVICE LABEL as required per NFPA 101 provides a service record for customer and local authorities. Both Service labels are priced per roll of 100 labels. Each label measures 3¼" x 1½". **CUSTOM LIGHTING SERVICE LABEL** imprinted with your company name, address and phone number. There is a **three-roll minimum** for the Custom labels.

PART#	DESCRIPTION
ELTL	Emergency Lighting Test Label, Blank
CUELTL	Emergency Lighting Test Label, Custom, 3 Roll Minimum



CUELTL

SEALED LEAD ACID BATTERY TESTER uses accurate pulse load testing to test battery performance – not just voltage/internal resistance. This tester identifies weak or failing batteries in alarm systems. Testing capacity (models) includes 2-volt (2-25AH), 4-volt (2-25AH), 6-volt (1-4AH, 5-15AH, 16-50AH, 20-100AH, 50-200AH), 8-volt (2-20AH, 20-100AH) and 12-volt (1-4AH, 5-15AH, 16-50AH, 20-100AH, 50-200AH). Requires 4 x AA batteries (not included). Test duration is approximately 15 seconds. Comes standard with 48" rubber coated lead wire, solid copper clamps, R/A sheathed banana plugs. Dimensions: 9¼" x 6¼" x 2".

PART#	DESCRIPTION
CELL03	Lead Acid Battery Tester Only
CELLCHECK	Lead Acid Battery Tester w/ CELLCASE
CELLCASE	Soft Technician's Case for Cellcheck



CELL03



CELLCHECK

Brooks' **MULTI-METER** is versatile and compact. The unit will measure both AC & DC and determine continuity of lamp. Unit also has a display locking feature.

PART#	DESCRIPTION
DM73B	Compact Multi-meter



DM73B

Brooks' **GLASS STRAPPING TAPE** is perfect for holding down exit sign and emergency light test buttons. Each roll comes with its own dispenser.

PART#	DESCRIPTION
GSTAPE	Glass Strapping Tape - Package of 1



GSTAPE

The **MINI VOLT STIK** is a non-contact voltage tester. It will indicate if voltage is present without actually coming in contact with the voltage source. Features audible and visual indications, positive battery check and shirt pocket clip. Test range is 50 – 600VAC. Batteries included.

PART#	DESCRIPTION
VT201	MINI VOLT STIK



VT201

BATTERY LEADS replace old, corroded battery leads to ensure optimum battery performance. The UBL can also be used to retrofit any existing lead connection. The PBL is ideal for use when replacing a battery with a plug connector attached.

PART#	DESCRIPTION
UBL	Universal Battery Lead (Set)
PBL	Plug Battery Lead (Set)



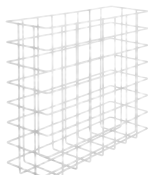
UBL

WIRE GUARDS

STI Exit Sign Damage Stopper®

- Guard helps protect against vandalism and damage
- Constructed of 9-gauge, welded steel wire, coated with a tough, corrosion resistant polyester shell
- Fast and easy installation with anchors and screws included (Tamper resistant hardware is available)
- Simple removal for light bulb replacement
- All dimensions listed are internal
- Battery Unit Models listed under Applications are based on dimensions with PAR18 Small Heads
- Models may be shown under Applications for both Exit and Emergency Lighting Cage section

!! NOTE: When lights are used for emergency exit corridor lighting, this guard can reduce projected light reading on floor. Verify field conditions as required by NFPA 101 life safety.



STI9741



STI9742



STI9640



STI9740

PART#	DESCRIPTION	W	H	D	APPLICATIONS
STI9741	Exit Sign Damage Stopper® Ceiling Mount	14.8"	16"	5.35"	EXST, RPST, RPNP, EXPTU
STI9742	Exit Sign Damage Stopper® Wall Mount	15.6"	16"	3.3"	RPNP
STI9640	Exit Sign Damage Stopper®	13.5"	10.5"	2.75"	EXPTU, EXST, RPST, LED1, LEDAC
STI9740	Exit Sign Damage Stopper®	20.5"	10.5"	6"	SXST
WGD590	Emergency / Exit Light Wire Guard	15.25"	14.25"	6.75"	Wall Mount CSR, CXST

STI Emergency Lighting Cage

- Guard helps protect against vandalism and damage
- Constructed of heavy gauge coated steel wire and coated with corrosion resistant polyester
- Fast and easy installation
- Simple removal for servicing unit
- Battery Unit Models listed under Applications are based on dimensions with PAR18 Small Heads
- Models may be shown under Applications for both Exit and Emergency Lighting Cage section

PART#	DESCRIPTION	W	H	D	APPLICATIONS
STI9641	Emergency Lighting Cage	14.6"	10.7"	4"	EBST Cab A, B
STI9645	Emergency Lighting Cage	21.6"	13.75"	5.9"	1PLG, S1HRD, R2HRD
WGD590	Emergency / Exit Light Wire Guard	15.25"	14.25"	6.75"	EBST Cab C

FIRE ALARM AND EMERGENCY LIGHT BATTERIES

ALKALINE BATTERIES

Energizer® ALKALINE BATTERIES are designed for today's heavy current or continuous use applications. These batteries have no mercury added; therefore, special disposal is not required. They operate well with temperature extremes (-20°F to 130°F), with excellent shelf life.

PART#	DESCRIPTION
ALK92	AAA Alkaline Battery, Energizer Industrial
ALK91	AA Alkaline Battery, Energizer Max
ALK93	C Alkaline Battery, Energizer Industrial
ALK95	D Alkaline Battery, Energizer Max
ALK22	9V Alkaline Battery, Energizer Max



ALK92



ALK91



ALK93



ALK95



ALK22

LITHIUM BATTERIES

For the countless electronic gadgets you can't live without, rely on Energizer® Advanced Lithium Batteries.

- Up to 10-year backup battery in AC-powered smoke detectors
- Last up to 20% longer in toys versus Energizer® MAX®
- Weigh ¼ less than standard alkaline
- Perform in extreme temperatures from -40°F to 140°F
- Leak-resistant construction



U9VL

PART#	DESCRIPTION
U9VL	9V Lithium Battery, Energizer Advanced

SEALED LEAD ACID BATTERIES

STEEL EMERGENCY LIGHT BATTERIES are one of the most powerful and economical batteries you can buy.

Batteries will be shipped separately from other items ordered and those items will be shipped according to our regular freight policy. All battery orders placed before 1pm Eastern Standard Time will be shipped same day! Orders placed after will be shipped next day. The approximate shipping times via GROUND to major cities across Canada are as follows:

Ontario and Quebec – Next day delivery (some rural areas may be two days)

East Coast – NS, NB, PEI – 2 days; NFLD – 4 days

Central Canada (Manitoba, Saskatchewan) – 2 – 3 days

Western Canada – 3 days to Calgary / Edmonton

NWT, YK – 6 days

BC - Next day

PART#	DESCRIPTION	LxWxH	CASE QTY
RS65	6V 5AH	2¾" x 1⅞" x 4"	20
RS67	6V 7.5AH	6" x 1⅞" x 3¾"	10
RS610	6V 10AH	6" x 2" x 3¾"	10
RS612	6V 12AH	6" x 2" x 3¾"	10
RS125	12V 5AH	3½" x 2¾" x 4"	10
RS127	12V 7.2AH	6" x 2½" x 3¾"	8
RS1233	12V 33AH	7⅜" x 6⅞" x 7⅞"	1
RS1242*	12V 42AH	7¾" x 6½" x 6¾"	1
RS1255*	12V 55AH	9⅝" x 5⅝" x 8⅞"	1
RS1275	12V 75AH	10¼" x 6⅝" x 8⅝"	1

*Nut & Bolt Terminals

ZONE 1 - ON (EXCEPT THUNDER BAY), PQ

ZONE 2 - MB, NS, SK, THUNDER BAY, NB

ZONE 3 - AB, BC, NFLD, PEI

ZONE 4 - NWT, YK



RS65



RS67



RS610



RS612



RS125



RS127



RS1233



RS1242



RS1255

MORE BATTERIES AVAILABLE. CONTACT CUSTOMER SERVICE FOR MORE INFORMATION. FIRE ALARM BATTERIES CAN BE FOUND ON PAGE 96 OF THE FIRE ALARM SECTION.



Return your lead acid batteries to Steel Fire Equipment and we will recycle them for you

REPLACEMENT BULBS

Replacement **BULBS** for exit signs, emergency lighting, and various other applications.

BI PIN BASE

PART#	DESCRIPTION
B68BP	6V, 8W Quartz Bi Pin
B612BP	6V, 12W Quartz Bi Pin
B620BP	6V, 20W Quartz Bi Pin
B1212BP	12V, 12W Quartz Bi Pin
B1220BP	12V, 20W Quartz Bi Pin
B2420BP	24V, 20W Quartz Bi Pin
BF6T5	120V, 6W Miniature Bi Pin (F6T5)
BF8T5	120V, 8W Miniature Bi Pin (F6T5)
LIQ024V012WB	24V, 12W Quartz Bi Pin



WEDGE BASE

PART#	DESCRIPTION
B914	4V, 3.6W Miniature Wedge
B909	6V, 3.7W Miniature Wedge
B939	6V, 5.4W Miniature Wedge
B927	6V, 7.2W Miniature Wedge
B915	12V, 9W Miniature Wedge
B912	12V, 12.8W Miniature Wedge
B908	6V, 9W Tungsten Wedge
B1218W	12V, 18W Tungsten Wedge
B249W	24V, 9W Tungsten Wedge
B2418W	24V, 18W Tungsten Wedge



SINGLE AND DOUBLE BAYONET CONTACT BASE



PART#	DESCRIPTION
B170	4V, 7.2W Dbl. Contact Bayonet
BT82	6V, 6.63W Dbl. Contact Bayonet
B47	6.3V, 0.9W Single Contact Bayonet (47T3.25)
B69	6V, 9W Double Contact Bayonet
BT126	12V, 6W Double Contact Bayonet
BT129	12V, 9W Double Contact Bayonet
B249	24V, 9W Double Contact Bayonet
BT65DC	120V, 20W Dbl. Contact Bayonet (20T6.5)

SCREW BASE



PART#	DESCRIPTION
B7C7	120V, 7W Candelabra Screw
BT65S	120V, 20W Intermediate Screw (20T6.5)
B25T10	120V, 25W Medium Screw Base (25T10)
BT6	145V, 15W Candelabra Screw (15T6)

SEALED BEAM



PART#	DESCRIPTION
SB612	6V, 12W Sealed Beam Lamp (PAR36)
B4044	12V, 12W Sealed Beam Lamp
B4446	12V, 25W Sealed Beam Lamp
BH7555	12V, 8W Sealed Beam Halogen (PAR36)

LED RETROFIT

The **BLRKITR** retrofit kit comes complete with two red LED lamps, two intermediate base adapters, two double contract base adapters and two DayGlo lenses (for use on 120 VAC circuits only). Five-year warranty with 50,000-hour life expectancy.

PART#	DESCRIPTION
BLRKITR	Red EXIT Sign LED Retrofit Kit w/ bases, Pkg/2



Our **RTR0** exit sign lamp (120VAVC 60Hz input) consumes just 1.2 watts of AC power. Includes candelabra, intermediate, medium, and DC Bayonet base.

PART#	DESCRIPTION
RTR0	120 VAC LED Retrofit Lamps c/w bases

Remote Head Retrofit

PART#	DESCRIPTION
LEME6T024V4WWSP-RV	4W LED for 6 to 24V Units, Wedge Base
LEME6T024V4WBSP-RV	4W LED for 6 to 24V Units, BiPin Base

COMPACT FLUORESCENT BASE

PART#	DESCRIPTION
BPL5	120V, 5W Compact Fluorescent
BPL7	120V, 7W Compact Fluorescent



EXIT LIGHTS

PART#	BATTERY BACK-UP	REPLACEMENT BATTERY	LIGHT SOURCE	REPLACEMENT AC	LAMPS DC	LISTINGS
LED1	YES	NICAD	LED	REPLACE UNIT	-	ULC
LEDAC	NO	NONE	LED	REPLACE UNIT	-	ULC
E660SP	YES	NICAD	LED	-		CSA, C860
ELER/FLSR	NO	NONE	LED	LMRONIV	NONE	CSA, C860
ELMCEI	NO	NONE	INCANDESCENT	BT6	NONE	CSA
FLMCEI	NO	NONE	INCANDESCENT	BT6	NONE	CSA
LMCN3L	NO	NONE	INCANDESCENT	BT6	NONE	CSA
CLXW	NO	NONE	INCANDESCENT	BT6	NONE	ULC
EXU	NO	NONE	LED	REPLACE UNIT		CSA
SXU	NO	NONE	LED	REPLACE UNIT		CSA

COMBINATION EXIT/ EMERGENCY LIGHTS

PART#	BATTERY BACK-UP	REPLACEMENT BATTERY	LIGHT SOURCE	REPLACEMENT AC	LAMPS DC	LISTINGS
LED4	YES	RS64x2	LED	REPLACE UNIT	B939	ULC
RG36EXITLED	YES	RS67	LED	LMRONIV	B939	CSA
RG28EXITLED	YES	RS64	LED	LMRONIV	B939	CSA
RG36SORTIELED	YES	RS67	LED	LMRONIV	B939	CSA
NH50	YES	RS64/RS645	LED	LMRONIV		CSA
RG36EXIT	YES	RS67	INCANDESCENT		B939	CSA
RG36SORTIE	YES	RS67	INCANDESCENT		B939	CSA
CLTSRW	YES	GSB65	INCANDESCENT	6V, 5W MR 16	B939	ULC
CXST636	YES	RS65	LED	6V, 9W	B908	CSA
CSST636	YES	RS65	LED	6V, 9W	B908	CSA

EMERGENCY LIGHTS

PART#	BATTERY BACK-UP	REPLACEMENT BATTERY	REPLACEMENT LAMPS	VOLTS/WATTS	REMOTE LAMPHEADCAPABILITY	LISTINGS
1PLG	YES	RS64	B939	6V, 5.4W	NO	ULC
S1HRD	YES	RS64	B939	6V, 5.4W	NO	ULC
R2HRD	YES	RS67	B939	6V, 5.4W	2-8H OR 1-10RH	ULC
RG362MT	YES	RS67	B908	6V, 9W	MT1 OR MT2	CSA
RG272MT	YES	RS64	B908	6V, 9W	MT1 OR MT2	CSA
6COM36C	YES	RS64	B908	6V, 9W	MT1 OR MT2	ULC
CLZW	YES	RS64	B939	6V, 5.4W	NO	ULC
EB636-2	YES	RS65	B908	6V, 9W	RMSM1 OR RMSM2	CSA
EB636-2HP	YES	RS67	B908	6V, 9W	RMSM1 OR RMSM2	CSA
EB672-2	YES	RS612	B908	6V, 9W	RMSM1 OR RMSM2	CSA
EB12100-2	YES	RS612 x 2	B908	6V, 9W	RMSM1 OR RMSM2	CSA
EB12200-2	YES	RS127 x 2	B908	6V, 9W	RMSM1 OR RMSM2	CSA
EB12360-2	YES	RS1233	B908	6V, 9W	RMSM1 OR RMSM2	CSA

- **SIGNS**
- **LABELS**
- **TAGS**





EXAMPLE #1



EXAMPLE #2



EXAMPLE #3



EXAMPLE #4



EXAMPLE #5

CUSTOM ENGRAVED SIGNS

Two exciting options available - **PLASTIC WITH PRE-PUNCHED HOLES** or **PLASTIC WITH ADHESIVE BACK**

- Custom made to your specifications - up to 432 square inches
- Seven different colour schemes available
- Comes complete with pre-punched corner holes or adhesive backs
- Service your non-traditional sign needs with our custom signs up to 24" x 18"

EXAMPLES:

PLASTIC WITH PRE-PUNCHED HOLES



RED ON WHITE

PLASTIC WITH ADHESIVE BACK



RED ON WHITE

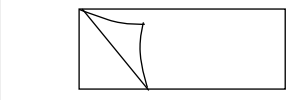
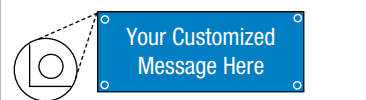
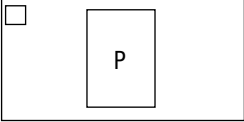
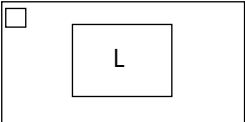
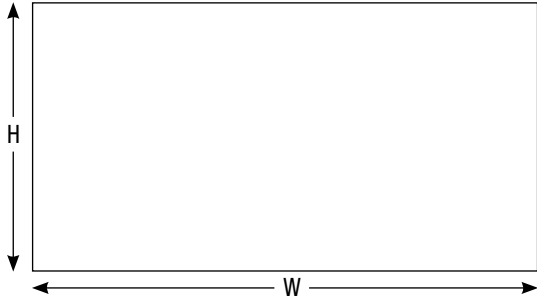


BLACK ON YELLOW

TO ORDER

PHOTOCOPY THIS ORDER FORM AND FAX TO 1-800-387-9990

CUSTOM ENGRAVED SIGNS EASY ORDER FORM 2 TO 3 WEEK DELIVERY

ORDERED BY	4. Check (✓) the colour you want																						
Company Name	<input type="checkbox"/> Red on White (RW)	<input type="checkbox"/> White on Red (WR) <input type="checkbox"/> Black on Yellow (BKY)																					
Account #	<input type="checkbox"/> White on Blue (WB)	<input type="checkbox"/> White on Green (WG) <input type="checkbox"/> Black on White (BKW)																					
Purchase Order	<input type="checkbox"/> White on Black (WBK)																						
Ordered By	5. What do you want your sign to say?																						
Phone Fax	LINE 1:																						
SHIP TO	LINE 2:																						
Name	LINE 3:																						
Address	LINE 4:																						
Address	6. Check (✓) the type of mounting you want																						
City Province Postal Code	<input type="checkbox"/> ADHESIVE BACKING 	<input type="checkbox"/> CORNER HOLES 																					
DIRECTIONS	7. Add colour code to part number(s) and insert quantities.																						
1. Check (✓) the orientation you want	CUSTOM ENGRAVED SIGNS WITH PRE-PUNCHED CORNER HOLES																						
<input type="checkbox"/>  Portrait	<input type="checkbox"/>  Landscape	CALL FOR PRICING																					
2. What dimensions do you want? _____ "H _____ "W	<table border="1" style="width: 100%; border-collapse: collapse;"> <thead> <tr> <th>P/N</th> <th>DESCRIPTION</th> <th>QTY</th> </tr> </thead> <tbody> <tr> <td>CS15 ___</td> <td>Customer Engraved Sign up to 15 sq in</td> <td></td> </tr> <tr> <td>CS30 ___</td> <td>Customer Engraved Sign 16 to 30 sq in</td> <td></td> </tr> <tr> <td>CS96 ___</td> <td>Customer Engraved Sign 31 to 96 sq in</td> <td></td> </tr> <tr> <td>CS144 ___</td> <td>Customer Engraved Sign 97 to 144 sq in</td> <td></td> </tr> <tr> <td>CS228 ___</td> <td>Customer Engraved Sign 145 to 228 sq in</td> <td></td> </tr> <tr> <td>CS432 ___</td> <td>Customer Engraved Sign 229 to 432 sq in</td> <td></td> </tr> </tbody> </table>		P/N	DESCRIPTION	QTY	CS15 ___	Customer Engraved Sign up to 15 sq in		CS30 ___	Customer Engraved Sign 16 to 30 sq in		CS96 ___	Customer Engraved Sign 31 to 96 sq in		CS144 ___	Customer Engraved Sign 97 to 144 sq in		CS228 ___	Customer Engraved Sign 145 to 228 sq in		CS432 ___	Customer Engraved Sign 229 to 432 sq in	
P/N	DESCRIPTION		QTY																				
CS15 ___	Customer Engraved Sign up to 15 sq in																						
CS30 ___	Customer Engraved Sign 16 to 30 sq in																						
CS96 ___	Customer Engraved Sign 31 to 96 sq in																						
CS144 ___	Customer Engraved Sign 97 to 144 sq in																						
CS228 ___	Customer Engraved Sign 145 to 228 sq in																						
CS432 ___	Customer Engraved Sign 229 to 432 sq in																						
Maximum Sign Size: 18"H x 24"W Minimum Size: 1"H x 2"W	CUSTOM ENGRAVED SIGNS WITH FOAM ADHESIVE BACKING																						
3. If you have a special design or layout, draw it in the large box (below).	<table border="1" style="width: 100%; border-collapse: collapse;"> <thead> <tr> <th>P/N</th> <th>DESCRIPTION</th> <th>QTY</th> </tr> </thead> <tbody> <tr> <td>CS15 ____A</td> <td>Customer Engraved Sign up to 15 sq in</td> <td></td> </tr> <tr> <td>CS30 ____A</td> <td>Customer Engraved Sign 16 to 30 sq in</td> <td></td> </tr> <tr> <td>CS96 ____A</td> <td>Customer Engraved Sign 31 to 96 sq in</td> <td></td> </tr> <tr> <td>CS144 ____A</td> <td>Customer Engraved Sign 97 to 144 sq in</td> <td></td> </tr> <tr> <td>CS228 ____A</td> <td>Customer Engraved Sign 145 to 228 sq in</td> <td></td> </tr> <tr> <td>CS432 ____A</td> <td>Customer Engraved Sign 229 to 432 sq in</td> <td></td> </tr> </tbody> </table>	P/N	DESCRIPTION	QTY	CS15 ____A	Customer Engraved Sign up to 15 sq in		CS30 ____A	Customer Engraved Sign 16 to 30 sq in		CS96 ____A	Customer Engraved Sign 31 to 96 sq in		CS144 ____A	Customer Engraved Sign 97 to 144 sq in		CS228 ____A	Customer Engraved Sign 145 to 228 sq in		CS432 ____A	Customer Engraved Sign 229 to 432 sq in		CALL FOR PRICING
P/N	DESCRIPTION	QTY																					
CS15 ____A	Customer Engraved Sign up to 15 sq in																						
CS30 ____A	Customer Engraved Sign 16 to 30 sq in																						
CS96 ____A	Customer Engraved Sign 31 to 96 sq in																						
CS144 ____A	Customer Engraved Sign 97 to 144 sq in																						
CS228 ____A	Customer Engraved Sign 145 to 228 sq in																						
CS432 ____A	Customer Engraved Sign 229 to 432 sq in																						
																							

FIRE EXTINGUISHER SIGNS

3D Rigid Plastic

Rigid, tough plastic (1/32" thick) with 1/8" diameter holes for easy perpendicular wall mounting. Screen printed with UV inks.

PART#	DESCRIPTION	W	H
PTD108	"Fire Extinguisher" Arrow, 3D Stand-Out	4"	12"
PTD109	"Fire Extinguisher" Arrow, 3D Stand-Out	4"	18"
PTD182	"Fire Extinguisher", Pictogram, Arrow, 3D Stand-Out	5"	6"
RSP3D56	Fire Extinguisher Pictogram, Arrow, 3D Stand-Out	5"	6"



Aluminum

Aluminum signs have smooth finished edges, rounded corners and predrilled mounting holes. Silk screened and then oven baked for long lasting durability.

PART#	DESCRIPTION	W	H
A107	Fire Extinguisher Arrow	12"	8"
A108	Fire Extinguisher Arrow	4"	12"
A109	Fire Extinguisher Arrow	4"	18"
A114	Fire Extinguisher Arrow	8"	12"
FS116	"Extincteur D'Incendie" Arrow	4"	18"
EDS117	"Fire Extinguisher" Arrow, 90° Double Sided	4"	12"
AWM114	"Fire Extinguisher" Arrow, 90° Double Sided	8"	12"



Rigid Plastic

Rigid, tough plastic (1/32" thick) mounts easily to the wall with predrilled mounting holes. Screen printed with UV inks.

PART#	DESCRIPTION	W	H
FSP114	"Extincteur D'Incendie" Arrow	8"	12"
FSP115	"Extincteur D'Incendie" Arrow	4"	12"
FSP116	"Extincteur D'Incendie" Arrow	4"	18"
RP107	"Fire Extinguisher" Arrow	12"	8"
RP109	"Fire Extinguisher" Arrow	4"	18"
RP114	"Fire Extinguisher" Arrow	8"	12"
RP189	K-Class "Fire Extinguisher" Arrow, Bilingual	8"	12"
RP257	Class D Sign	10"	7"
RSP108	"Fire Extinguisher" Arrow	4"	12"



Rigid Plastic 90° Angle Signs

Rigid tough plastic (1/32" thick) mounts perpendicular to wall easily with key-holed slots. Screen printed with UV inks on both sides.

PART#	DESCRIPTION	W	H
PWM108	"Fire Extinguisher" Arrow, 90° Double Sided	4"	12"
PWM109	"Fire Extinguisher" Arrow, 90° Double Sided	4"	18"
PWM114	"Fire Extinguisher" Arrow, 90° Double Sided	8"	12"
PWM115	Fire Extinguisher Pictorial, 90° Double Sided	8"	12"
PWM119	"Extincteur D'Incendie" Arrow, 90° Double Sided	4"	12"
PWM120	"Extincteur D'Incendie" Arrow, 90° Double Sided	4"	18"
PWM121	"Extincteur D'Incendie" Arrow, 90° Double Sided	8"	12"
PBL101	Fire Hose and Extinguisher Pictogram, Bilingual	8"	12"



Vinyl Self Adhesive Signs

Self-Adhesive vinyl signs are silk screened with UV inks, then clear laminated for durability and fade resistance. Mounting surface must be clean, dry, smooth, and non-porous. To mount these on a porous surface, such as brick or concrete block, use our Sign On! Aerosol adhesive P/N BA1.

PART#	DESCRIPTION	W	H
BL105	"Fire Extinguisher Inside"	4"	4"
BL106	"Fire Extinguisher - In Case of Fire Break Glass", Bilingual	6"	2"
EBL106	"Fire Extinguisher - In Case of Fire Break Glass"	6"	2"
BL107	Fire Extinguisher Arrow	12"	8"
BL108	"Fire Extinguisher" Arrow	4"	12"
BL109	"Fire Extinguisher" Arrow	4"	18"
BL114	Fire Extinguisher Arrow	8"	12"
BL116	"Fire Extinguisher Inside"	6"	9"
BL120	Fire Extinguisher	12"	4 1/2"
BL123	"Warning \$500 Fine..."	4"	4"
BL127	Wrap Around Column Fire Extinguisher Arrow	24 1/2"	12 1/2"
BL128	"Warning...Electronic Alarm"	6"	2"
BL132	"Fire Extinguisher Missing"	4"	4"
BL135R	"Fire", Red, Die Cut	3"	8 1/2"
BL172	"Fire Extinguisher Inside"	4"	3"
BL183	"Fire Extinguisher Inside"	18"	2"
FBL105	"Extincteur D'Incendie a L'Interieur"	4"	4"
FBL107	"Extincteur D'Incendie"	12"	8"
FBL108	"Extincteur" Arrow	4"	12"
FBL109	"Extincteur" Arrow	4"	18"
FBL114	"Extincteur D'Incendie"	8"	12"
FBL116	"Extincteur D'Incendie"	6"	9"
FBL123	"AVIS Amende de \$1000..."	4"	4"
FBL128	"AVIS Equipment D'incendie protégé par..."	6"	2"



Brooks Sign On

Multi-purpose adhesive bonds signs to almost anything. Great for porous surfaces, such as brick or concrete block.

PART#	DESCRIPTION
BA1	Brooks Sign On Adhesive



BA1

EXTINGUISHER CABINET DECALS

Vinyl Self Adhesive Signs

Self-Adhesive vinyl signs are silk screened with UV inks, then clear laminated for durability and fade resistance. Mounting surface must be clean, dry, smooth, and non-porous. To mount these on a porous surface, such as brick or concrete block, use our Sign On! Aerosol adhesive P/N BA1.

PART#	DESCRIPTION	W	H
BLM12	"Pull Here" For Fire Extinguisher Cabinet Covers	4"	2½"
FBLM12	French "Pull Here" For Fire Extinguisher Cabinet Covers	4"	2½"
BL253	Fire Extinguisher Cabinet and Bubble Front Decal	12"	19"
BL254	Fire Extinguisher Cabinet Decal	9"	2¾"
BL106	"Fire Extinguisher - In Case of Fire Break Glass", Bilingual	6"	2"
EBL106	"Fire Extinguisher - In Case of Fire Break Glass"	6"	2"



BLM12



FBLM12



BL106



BL253



BL254



EBL106

EXIT SIGNS AND DIRECTIONAL ARROWS

3D Rigid Plastic

Rigid, tough plastic (1/32" thick) with 1/8" diameter holes for easy perpendicular wall mounting. Screen printed with UV inks.

PART#	DESCRIPTION	W	H
PTD112	"Exit" 3D Stand-Out Sign	12"	8"



PTD112

Aluminum

Aluminum signs have smooth finished edges, rounded corners and predrilled mounting holes. Silk screened and then oven baked for long lasting durability.

PART#	DESCRIPTION	W	H
A112	"Exit"	12"	8"



A112

Rigid Plastic

Rigid, tough plastic (1/32" thick) mounts easily to the wall with predrilled mounting holes. Screen printed with UV inks.

PART#	DESCRIPTION	W	H
RP112	"Exit"	12"	8"
RP117	"In Case of Fire...Use Stairways"	5½"	7"



RP112



RP117

Vinyl Self Adhesive Signs

Self-Adhesive vinyl signs are silk screened with UV inks, then clear laminated for durability and fade resistance. Mounting surface must be clean, dry, smooth, and non-porous. To mount these on a porous surface, such as brick or concrete block, use our Sign On! Aerosol adhesive **P/N BA1**.

PART#	DESCRIPTION	W	H
BL112	"Exit", Red	12"	8"
BL112W	"Exit", White	12"	8"
BL113	Arrow	5"	8"
BL117	"In Case of Fire...Use Stairways"	5"	7"
BL1186	Emergency Exit Unlocked By Fire Alarm	5"	3"
BL121	Arrow	12"	1½"
BL126	"Not An Exit"	10"	9"
BL133	Directional Arrow	4" Dia.	2"
BL137	This Door to Remain Unlocked During Working Hours	23"	1⅞"
BL167	"Fire Door - Keep Closed"	12"	6"
BL168	Emergency Exit Only	12"	6"
BL169	Emergency Exit Only Alarm Will Sound	12"	6"
BL187	This Door to Remain Unlocked When the Building is Occupied	12"	6"
FBL112	"Sortie"	10"	8"



FIRE ALARM SIGNS

3D Rigid Plastic

Rigid, tough plastic (1/32" thick) with 1/8" diameter holes for easy perpendicular wall mounting. Screen printed with UV inks.

PART#	DESCRIPTION	W	H
PTD156	"Fire Alarm" Stand-Out Sign	4"	12"



Vinyl Self Adhesive Signs

Self-Adhesive vinyl signs are silk screened with UV inks, then clear laminated for durability and fade resistance. Mounting surface must be clean, dry, smooth, and non-porous. To mount these on a porous surface, such as brick or concrete block, use our Sign On! Aerosol adhesive **P/N BA1**.

PART#	DESCRIPTION	W	H
BL119	"Fire Alarm" Arrow	8"	12"
BL185	"Fire Alarm Pull Station Inside"	4"	4"



FIRE HOSE SIGNS

Rigid Plastic

Rigid, tough plastic (1/32" thick) mounts easily to the wall with predrilled mounting holes. Screen printed with UV inks.

PART#	DESCRIPTION	W	H
PBL100	Fire Hose Pictorial, Bilingual	8"	12"
PBL101	Fire Hose and Extinguisher Pictorial, Bilingual	8"	12"
PWM125	"Fire Hose" Arrow	4"	18"



PBL100



PBL101



PWM125

Vinyl Self Adhesive Signs

Self-Adhesive vinyl signs are silk screened with UV inks, then clear laminated for durability and fade resistance. Mounting surface must be clean, dry, smooth, and non-porous. To mount these on a porous surface, such as brick or concrete block, use our Sign On! Aerosol adhesive **P/N BA1**.

PART#	DESCRIPTION	W	H
BL111	"Fire Hose"	12"	4"
BL118	"Fire Hose" Arrow	8"	12"
BL124	Hose Rack Pictorial Instructional	13"	2 3/4"
BL125	"Fire Hose" Arrow	4"	18"
BL300	"Fire Hose for use by Trained Persons Only" Reverse Label	9 3/4"	2"
BL301	"Fire Hose for use by Trained Persons Only" Reverse Label, Bilingual	9 3/4"	4"
BL303	"Fire Hose for use by Trained Persons Only"	9 3/4"	2"



BL111



BL300



BL118



BL125



BL301



BL303



BL124

FIRST AID SIGNS

3D Rigid Plastic

Rigid, tough plastic (1/32" thick) with 1/8" diameter holes for easy perpendicular wall mounting. Screen printed with UV inks.

PART#	DESCRIPTION	W	H
PTD176	"Emergency Eye Wash... Keep Area Clear"	18"	10"
PTD261	"AED" Stand-Out Arrow	5"	6"
PTD262	"First Aid" Arrow	5"	6"



PTD176



PTD261



PTD262

Rigid Plastic

Rigid, tough plastic (1/32" thick) mounts easily to the wall with predrilled mounting holes. Screen printed with UV inks.

PART#	DESCRIPTION	W	H
RP144A	"Emergency... First Aid Station"	8"	10"
RP176A	"Emergency... Eye Wash Keep Area Clear"	7"	10"



RP144A



RP176A

Vinyl Self Adhesive Signs

Self-Adhesive vinyl signs are silk screened with UV inks, then clear laminated for durability and fade resistance. Mounting surface must be clean, dry, smooth, and non-porous. To mount these on a porous surface, such as brick or concrete block, use our Sign On! Aerosol adhesive **P/N BA1**.

PART#	DESCRIPTION	W	H
BL144	"First Aid Station"	8"	12"
BL157	"First Aid Kit Inside"	4"	4"
BL170	"Fire Blanket" Arrow	4"	18"
G261	"AED Automated External Defibrillator"	6"	8"



BL144



BL157



BL170



G261

DANGER SIGNS

Rigid Plastic

Rigid, tough plastic (1/32" thick) mounts easily to the wall with predrilled mounting holes. Screen printed with UV inks.

PART#	DESCRIPTION	W	H
RSPHV	Danger High Voltage	10"	8"
RP145	Danger Safety Glasses	10"	8"
RP146	Danger Flammable Liquids	10"	8"
RP150A	ANSI Z535 Danger Flammable	7"	10"
RP151	Danger Hard Hat Area	10"	8"
RP152	Danger Keep Out	10"	8"
RP153	Danger Do Not Enter	10"	8"
RP154	Danger Ear Protection Required	10"	8"
RSPAP	Danger Authorized Personnel Only	10"	8"
RSPNS	Danger No Smoking	10"	8"
RSPCA	Danger Construction Area	10"	8"



RSPHV



RP145



RP146



RP150A



RP151



RP152



RP153



RP154



RSPAP



RSPNS



RSPCA

SPRINKLER IDENTIFICATION SIGNS

Aluminum

Sprinkler Identification Signs are made of aluminum, painted white, and printed with fade-resistant red ink. Each sign has predrilled mounting holes for easy installation.

NOTE: Signs are shipped with removable plastic film to prevent scratching, unless otherwise noted.

PART#	DESCRIPTION	W	H
A142 *	This Valve Controls	6"	4"
A143	Control Valve	6"	2"
A160	Inspection Test	6"	2"
A161	Main Drain	6"	2"
A162	Sprinkler Drain	6"	2"
A163	Alarm Test	6"	2"
A164 *	Hydraulic Data	6"	4"
A165	Sprinkler Fire Alarm	7¼"	6"
A221	Air Control	6"	2"
A222	Air Line	6"	2"
A223	Alarm Line	6"	2"
A224	Anti-Freeze System	6"	2"
A225	Auxiliary Drain	6"	2"
A226	This Valve Controls	9"	7"
A227	Drain	6"	2"
A228	Drain Valve	6"	2"
A229	Dry Standpipe	6"	2"
A230 *	Entire System	6"	2"
A232	Hydraulic System	5"	7"
A233	Main Control	6"	2"
A234	Normally Closed	6"	2"
A235	Normally Open	6"	2"
A236	Open Sprinkler Control	6"	2"
A237	Open Sprinkler Drain	6"	2"
A238	Sprinkler Valve Room	6"	2"
A239	Test & Drain	6"	2"
A240	Test Valve	6"	2"
A241	Water Motor Line	6"	2"
A242	Wet Standpipe	6"	2"
A243	Fire Sprinkler Valve	6"	2"



A142



A143



A160



A161



A162



A163



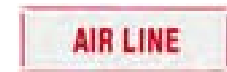
A164



A165



A221



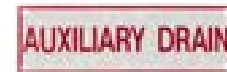
A222



A223



A224



A225



A226



A227



A228



A232



A229



A230



A233



A234



A235



A236



A237



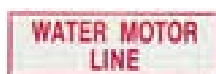
A238



A239



A240



A241



A242



A243

* This sign does not have plastic coating to prevent scratching

Rigid Plastic

Sprinkler Alarm Signs are made of plastic, painted red, and printed with fade-resistant white ink. Each circular sign has a predrilled mounting hole for easy installation over alarm bell. 7" Dia.

PART#	DESCRIPTION	Dia.
RP251	911 Fire Alarm Bell, Plastic	7"



RP251

Vinyl Self Adhesive Signs

Fire Sprinkler Labels, with arrow, are printed with fade-resistant red ink on white self-adhesive vinyl. Use them to identify sprinkler lines and direction of water flow. Rolls of 50 labels. 6" L x 2" H.

PART#	DESCRIPTION	W	H
BL252L	"Fire Sprinkler Line" with Left Arrow	6"	2"
BL252R	"Fire Sprinkler Line" with Right Arrow	6"	2"



BL252L



BL252R

FIRE DEPARTMENT AND SYSTEM SIGNS

Aluminum

Aluminum signs have smooth finished edges, rounded corners and predrilled mounting holes. Silk screened and then oven baked for long lasting durability.

PART#	DESCRIPTION	W	H
AF110	Hood Caution Sign, Bilingual	6"	2"
A245	"FDC" w/ Arrow, 4" Letters	10"	12"
A244	Fire Department Connection	6"	4"



AF110



A245



A244

Aluminum, Adhesive Backed

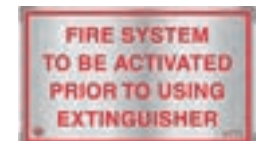
PART#	DESCRIPTION	W	H
A106	"Caution..." for System Hood	5"	2"
A272	Remote Pull Station	5"	3"
A273	Fire System	5"	3"
A276	Fryer	4"	2"
A277	Griddle	4"	2"
A278	Broiler	4"	2"
A281	Hood #1	4"	2"
A282	Hood #2	4"	2"
A283	Hood #3	4"	2"
A284	Hood #4	4"	2"



A106



A272



A273



A276



A277



A278



A281



A282



A283



A284

GLOW IN THE DARK SIGNS

Glow in the Dark Self Adhesive Signs

Glow in the dark self-adhesive signs will glow for up to 8 hours at a time after darkness occurs but are very visible in normal lighting. Cycling from light to darkness does not wear out the sign. Do not use household cleaner to clean glow in the dark signs, as it will cause the printing to run.

PART#	DESCRIPTION	W	H
G108	"Fire Extinguisher" Arrow	4"	12"
G109	"Fire Extinguisher" Arrow	4"	18"
G112	Exit	12"	8"
G113	Directional Arrow	8"	5"
G126	No Exit	5"	5¼"
G186	Fire Extinguisher	6"	1"
G261	"AED" Label, Self-Adhesive	6"	8"



PHOTOLUMINESCENT EXIT & RUNNING MAN SIGNS

Suitable for floor proximity installation. Can be used for both high-level and low-level applications.

- Zero energy consumption, zero cost, zero maintenance
- Non-toxic, non-radioactive, no disposal cost
- Movable if egress paths changed
- Visible at 15.25 meters (50 feet) for a minimum of 90 minutes

AimLite

- Life expectancy: 25+ years
- Explosion-proof

AIMP632AS Series

PART#	DESCRIPTION	W	H
AIMP632AS	Aluminum EXIT, Yellow Text on Red Background, 75 ft Visibility	15¼"	9"



AIMP631AS Series

PART#	DESCRIPTION	W	H
AIMP631AS	Aluminum SORTIE, Yellow Text on Red Background, 75 ft Visibility	22⅞"	8⅝"



NEW AIMP4000 Series

PART#	DESCRIPTION	W	H
▶ AIMP4343AS	Aluminum RM, Left Arrow 50 ft Visibility	15"	9"
▶ AIMP4344AS	Aluminum RM, Right Arrow 50 ft Visibility	15"	9"
▶ AIMP4973AS	Aluminum RM, Straight Thru 50 ft Visibility	15"	9"
▶ PF4001AS1WBK	Frame, Single Face, Wall Mount, Black		
▶ PF4001AS1CBK	Frame, Single Face, Ceiling Mount, Black		
▶ PF4001AS1EBK	Frame, Double Face, Ceiling Mount, Black		
▶ PF4001AS2EBK	Frame, Double Face, End Mount, Black		
▶ PF4001AS1WSI	Frame, Single Face, Wall Mount, Silver		
▶ PF4001AS1CSI	Frame, Single Face, Ceiling Mount, Silver		
▶ PF4001AS1ESI	Frame, Single Face, End Mount, Silver		
▶ PF4001AS2CSI	Frame, Double Face, Ceiling Mount, Silver		
▶ PF4001AS2ESI	Frame, Double Face, End Mount, Silver		



NO SMOKING SIGNS

Vinyl Self Adhesive Signs

Self-Adhesive vinyl signs are silk screened with UV inks, then clear laminated for durability and fade resistance. Mounting surface must be clean, dry, smooth and non-porous. To mount these on a porous surface, such as brick or concrete block, use our Sign On! Aerosol Adhesive **P/N BA1**.

PART#	DESCRIPTION	W	H
BL110	"No Smoking", 12" x 4"	12"	4"
BL115	"No Smoking", 8" x 10"	8"	10"
BL174	"No Smoking...Smoking Prohibited by Law"		
FBL115	Defense de Fumer	8"	10"



BL110



BL174



BL115



FBL115

Rigid Plastic

Rigid, tough plastic (1/32" thick) mounts easily to the wall with predrilled mounting holes. Screen printed with UV inks.

PART#	DESCRIPTION	W	H
RSPNS	Danger No Smoking	10"	8"



RSPNS

EXTINGUISHER OPERATING LABELS

Vinyl Self Adhesive Signs

Self-Adhesive vinyl signs are silk screened with UV inks, then clear laminated for durability and fade resistance. Mounting surface must be clean, dry, smooth, and non-porous. To mount these on a porous surface, such as brick or concrete block, use our Sign On! adhesive **P/N BA1**.

FIRE CLASSIFICATION LABELS

PART#	DESCRIPTION	W	H
BL101	"Use on all fires - ABC"	4½"	1¾"
BL101N	"ABCE Pictorial"	4½"	1¾"
BL102	"Use only on - BC"	4½"	1¾"
BL102N	"BC" Pictorial	3"	1¾"
BL103	"Use only on - A"	4½"	1¾"
BL103N	"A" Pictorial	4½"	1¾"
FBL101	"Utiliser sur toute"	4½"	1¾"
FBL101N	"ABC" Pictorial French	4½"	1¾"
FBL102	"Utiliser sur - BC..."	4½"	1¾"
FBL102N	"BC" Pictorial French	3"	1¾"
FBL103	"Utiliser sur - A..."	4½"	1¾"
FBL103N	"A" Pictorial French	4½"	1¾"



BL101



BL101N



BL102



BL102N



BL103



BL103N



FBL101



FBL101N



FBL102



FBL102N



FBL103



FBL103N

PICTORIAL OPERATING LABELS

PART#	DESCRIPTION	W	H
BL122	Extinguisher Instruction	5½"	2½"
BL200	ABC Extinguisher w/ Hose Instruction	3"	5¼"
BL201	ABC Extinguisher w/Nozzle Instruction	3"	5¼"
BL202	BC Extinguisher w/Hose Instruction	3"	5¼"
BL203	BC Extinguisher w/Nozzle Instruction	3"	5¼"
BL204	Water Extinguisher Instruction	3"	5¼"
BL207	ABC Cartridge Extinguisher Instruction	3"	5¼"
BL208	BC Cartridge Extinguisher Instruction	3"	5¼"
BL209	Vinyl Nameplate 5lbs. CO2 Instruction	5"	5¼"
BL210	Vinyl Nameplate Large CO2 Instruction	5"	5¼"
FBL122	Extinguisher Instruction - French version	5½"	2½"
FBL200	ABC Extinguisher w/Hose Instruction - French version	3"	5¼"
FBL201	ABC Extinguisher w/Nozzle Instruction - French version	3"	5¼"
FBL202	BC Extinguisher w/Hose Instruction - French version	3"	5¼"
FBL203	BC Extinguisher w/Nozzle Instruction - French version	3"	5¼"
FBL204	Water Extinguisher Instruction - French version	3"	5¼"
FBL207	ABC Cartridge Extinguisher Instruction - French version	3"	5¼"
FBL208	BC Cartridge Extinguisher Instruction - French version	3"	5¼"
FBL209	Vinyl Nameplate 5lbs. CO2 Instruction - French version	5"	5¼"
FBL210	Vinyl Nameplate Large CO2 Instruction - French version	5"	5¼"



BL122



BL200



BL201



BL202



BL203



BL204



BL207



BL208



BL209



BL210



FBL209



FBL210



FBL122



FBL201



FBL202



FBL203



FBL200



FBL204



FBL207



FBL208

WHMIS LABELS

WHMIS Labels

Blank WHMIS self-adhesive vinyl labels that can be used outside and can also be written on with pen or marker. Meets the new SDS requirements (except WLC, WLC02-OLD, WLN-OLD). Note: Do not install on front of extinguisher per NFPA10.

PART#	DESCRIPTION	W	H
WLC	CO2 Cartridge Blank Label OLD Format	2½"	1½"
WLC02	CO2 Blank Label SDS Format	2½"	1½"
WLDC	Dry Chemical Blank Label SDS Format	4"	2½"
WLN	Nitrogen Cartridge Blank Label SDS Format	2½"	1½"
WLPW	Pressure Water Blank Label SDS Format	4"	2½"



IN CASE OF FIRE LABELS

In Case of Fire Labels

In Case of Fire Labels are made of white vinyl with adhesive backs. For use in apartments, office buildings, etc. For use in 911 Areas Only. Labels are available that include the emergency procedures for buildings with a single-stage or two stage fire alarm and with or without elevators.

PART#	DESCRIPTION	W	H
2S30	2 Stage Alarm	4½"	7"
BL130	"In Case of Fire Break Front", Clear, Reversed	4¼"	1½"
F702	2 Stage Alarm - French	4½"	7"
FNE60	Single Stage, No Elevator - French	4½"	7"
FS01	Single Stage Alarm - French	4½"	7"
NE20	Single Stage, No Elevator	4½"	7"
S10	Single Stage Alarm	4½"	7"



TRANSPORT OF DANGEROUS GOODS LABELS

Non Flammable Gas Labels

UN 1044 Class 2.2 labels for fire extinguishers containing compressed or liquefied gas. Self-adhesive vinyl **NON-FLAMMABLE GAS LABELS**. Note: Do not install on front of extinguisher per NFPA10.

PART#	DESCRIPTION	W	H
BL171	Non-Flammable Gas Label, English, 500/Roll	4"	4"
EWLNFG	UN 1044 Fire Extgr Non-Flammable Gas Label, English, 100/Roll	2"	2"
FWLNFG	UN 1044 Fire Extgr Non-Flammable Gas Label, French, 100/Roll	2"	2"



Transport Canada and DOT Labels

Transport Canada (TC) labels meet the requirements of the Transportation of Dangerous Goods Regulations Section 4 - Appendix, IATA - 7.3, ICAO - 5.3, UMDG - 5.2.2.2.2. Labels are backed with a permanent adhesive back, scuff and scratch resistant, made to withstand rigors of harsh environment for up to 1 year.

PART#	DESCRIPTION	W	H
BL173	Carbon Dioxide UN 1013 Bilingual	5 7/8"	2 1/4"
BL177	Nitrogen Compressed UN 1066 Bilingual	5 1/4"	2 1/4"
BL180	Compressed Air UN 1002	5 7/8"	2 1/4"
BL181	Oxygen UN1072 Bilingual	5 3/4"	2 1/4"



US Department of Transportation (DOT) compressed gas labels, as required by DOT 49CFR, section 172.304 and 172.406. These labels feature self-adhesive heavy-duty material with tough, fade resistant inks. Ink will not come off with normal cleaning compounds.

PART#	DESCRIPTION	W	H
BL184	CO2 Cartridge UN 1013	3 3/4"	2"
BL188	Nitrogen Compressed UN 1066	3 3/4"	2"



CONDUCTIVITY, CYLINDER AND HYDROTEST LABELS

COMPOSITE CYLINDER TEST LABELS meet the requirements of Transport Canada for recording test information on composite cylinders. Sold per pkg of 50. Use our **5 MINUTE EPOXY** for applying over the composite test labels.

PART#	DESCRIPTION	Dia.
CRL50	Composite Cylinder Test Labels, Sold 50/pkg	2 1/2"
5ME	5 Minute Epoxy	



BLANK HYDROTEST AND 6 YEAR MAINTENANCE LABELS with an area to stamp your own name (with permanent ink). Silver metallic material that shows "VOID" when removed as recommended in NFPA10. Sold and priced per 100.

PART#	DESCRIPTION	W	H
6HTLBK	6-Year Blank Hydrotest, Silver Metallic	3 1/2"	2 1/4"



CUSTOM IMPRINTED HYDROTEST AND 6 YEAR MAINTENANCE LABELS with your company name, address and phone number. Silver metallic material that shows "VOID" when removed as recommended in NFPA10. Sold and priced per 100. Minimum order 500 (5 rolls). One Week delivery.

PART#	DESCRIPTION	W	H
6HTLCU	Custom 6-Year Blank Hydrotest, Silver Metallic	3 1/2"	2 1/4"



Our **CUSTOM CONDUCTIVITY TEST LABELS** come standard as blank, metallic colour with bilingual text. **CUSTOM** Metallic Conductivity Test Labels have a single line imprint area for Custom Name. Bilingual. One week delivery. Standard and Custom labels are sold 100 per roll.

PART#	DESCRIPTION	W	H
CTL2	Blank Conductivity Test Label	3"	3/4"
CUCTL2	Custom Conductivity Test Label	3"	3/4"



CTL2

CUCTL2

Our **CUSTOM FIRE HOSE HYDROSTATIC TEST LABELS** are printed with your Company Name. These labels are made of Polypropylene and come printed Bilingual. Sold 100 per roll.

PART#	DESCRIPTION	W	H
FHTL	Fire Hose Test Labels	3"	3/4"



FHTL

SERVICE TAGS

Yellow **BLANK SERVICE TAGS** are printed on both sides with black ink on 13 pt stock. Reinforced eyelets are standard. Great for those emergencies when you run out of your custom service tags. Packaged and priced per 100.

PART#	DESCRIPTION	W	H
STAGBK	Blank Service Tag, Yellow, 100/Pkg	2 3/8"	5 1/2"
FSTAGBK	French Blank Service Tag, Yellow, 100/Pkg	2 3/8"	5 1/2"



STAGBK Back



FSTAGBK Front & Back

Custom Service Tags

Custom-imprinted extinguisher **SERVICE TAGS** have the same basic information as our standard blank service tag and are printed on both sides with black ink on a coated 13-pt stock with reinforced eyelets. Metal eyelets and/or wire optional. **Deadline—every 10th and 25th of each month with delivery in six to eight weeks.** Years are changed automatically every October. Colors available: Yellow (Y), Light Blue (B), Light Green (G), Red (R), White (W). Minimum order of 2,000 for custom tags. **Tags are Priced per 1000 (M).**

Note: SSPRUSH 3 and 5 are not available for Tyvek® tags.

Plate charges apply each time the Custom Tag is altered. The exception is for English Tags ONLY. **For English Tags only, additional plate charges DO NOT APPLY for reprinting tags with a different Year.** French Tags require a Plate Charge for reprinting tags with changes in Year.

PART#	DESCRIPTION	W	H
SSPSTY	Yellow Custom Service Tag	2 5/8"	5 1/4"
SSPSTB	Light Blue Custom Service Tag	2 5/8"	5 1/4"
SSPSTG	Light Green Custom Service Tag	2 5/8"	5 1/4"
SSPSTR	Red Custom Service Tag	2 5/8"	5 1/4"
SSPSTW	White Custom Service Tag	2 5/8"	5 1/4"
PLATE	Plate Charge, New and Revised Orders Only		
LOGO	Logo Charge, New and Revised Orders Only		
SSPME	Metal Eyelets Add-On, Priced Per 1000		
SSPWIRE	Wire Attachment Add-On, Priced Per 1000		
SSP2CO	2nd Ink Add-On, Priced Per 1000		
SSP3CO	3rd Ink Add-On, Priced Per 1000		
SSPTVK	Tyvek Add-On, White Only (Min 2000), Priced Per 1000		
SSPTVKWIRE	Tyvek Wire Attachment Add-On, Priced Per 1000		
SSPFLU	Fluorescent Add-On (No Rush Delivery), Priced Per 1000		
SSPRUSH	Rush Charge, 2-3 Week Print Time (Max 10,000)		
SSPRUSH5	Rush, 5 Day Print Time (Max 10,000)		
SSPRUSH3	Rush, 3 Day Print Time (Max 10,000)		

Our **CUSTOM** printed extinguisher service tags with your imprint. These tags are completely customizable with your design, information and logo. Printed on both sides with black ink on coated stock. Reinforced eyelets standard. Available in seven different colours, yellow, light blue, light green, red, white, beige or orange. Minimum order of 5,000 for custom tags. **Allow 4 weeks for delivery. New Plate and Logo charge applies.**

PART#	DESCRIPTION	W	H
CSTAG	Plate Charge, New and Revised Orders Only	3"	5½"
CPLATE	Custom Tags New Plate Charge (1 per colour)		
CLOGO	Logo Charge, New and Revised Orders Only		



CSTAG

CUSTOMER REPAIR TAG allows you to write the work performed for each extinguisher and the total amount to be paid. Comes with a looped string for easy attachment around gauge and the bottom is perforated to give the customer his claim check. Tag is two colour (orange/white) and sold in packages of 100 each.

PART#	DESCRIPTION	W	H
CRTAG	Customer's Repair & Claim Check Tag	3⅞"	5½"



CRTAG

CONDEMNED TAG for extinguishers that need to be removed from service.

PART#	DESCRIPTION	W	H
ECTAG	Condemned Tag	5¼"	2¾"



ECTAG

INSPECTION TAGS

PLASTIC INSPECTION TAG for outside use. Strong, will not tear or break, will not crack or get brittle with age, unaffected by moisture, oils or grease. Twelve month record on yellow plastic.

PART#	DESCRIPTION	W	H
PTAG	Plastic Inspection Tag	2½"	4⅞"
FPTAG	Plastic Inspection Tag, French	2½"	4⅞"



PTAG



FPTAG

MONTHLY INSPECTION TAG and recharge record. This tag allows for recording service and inspection dates all on one tag. Printed in black and red ink on plastic stock.

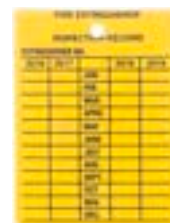
PART#	DESCRIPTION	W	H
ITAG	Monthly Inspection & Recharge Tag	2⅜"	5"



ITAG

FOUR YEAR PLASTIC INSPECTION TAGS are made of strong 23mm high density plastic. Tags will not break or tear, crack or become brittle with age. Unaffected by moisture, oils or grease.

PART#	DESCRIPTION	W	H
4PTAG	Plastic 4 Yr. Inspection Tag	2¼"	3"
F4PTAG	Plastic 4 Yr. Inspection Tag, French	2¼"	3"



4PTAG



F4PTAG

FOUR YEAR METAL INSPECTION TAGS for fire equipment monthly inspection. Great for outdoors! Use our extra fine permanent marker pen (Part #UFMP)

PART#	DESCRIPTION	W	H
TAG	4 Yr. Metal Inspection Tag	2¼"	3"
FTAG	4 Yr. Metal Inspection Tag, French	2¼"	3"



TAG



FTAG

Vinyl peel and stick **MONTHLY INSPECTION LABELS** printed with green ink on white vinyl material. Sold in rolls of 100.

PART#	DESCRIPTION	W	H
MTAG	Stick-On Inspection Tag	2"	3"



MTAG

FIRE HOSE INSPECTION AND TEST RECORD tags are printed with red ink on white card stock. Sold individually.

PART#	DESCRIPTION	W	H
FHTAG	Fire Hose Inspection & Test Record Tags	2½"	5¼"



FHTAG

MONTHLY INSPECTION TAGS are ideal for monthly reinspection of fire equipment. Sold 100/pkg.

PART#	DESCRIPTION	W	H
ERTAG	Monthly Inspection Tag, 100/Pkg	5¼"	2½"
FRTAG	Monthly Inspection Tag, French, 100/Pkg	5¼"	2½"



ERTAG



FRTAG

TAG COVERS AND FASTENERS

TAG COVERS are perfect for keeping dust and water away from your tags. Reliable, strong and will not crack.

PART#	DESCRIPTION	W	H	SPECS
STCP	Standard Tag Cover	3½"	6½"	• 2.5 mil Poly Plastic
HSTC	Heavy-Duty Tag Cover (V), Large	3¾"	7¼"	• 10 mil Frosty Matte Soft Vinyl • Withstands temperatures of -40°F to +130°F
HSTC2	Heavy-Duty Tag Cover (V), Small	3½"	6½"	• 10 mil Frosty Matte Soft Vinyl • Withstands temperatures of -40°F to +130°F
HTBZL1	Re-sealable Tag Cover (V)	3¾"	6¾"	• 10 mil Satin Vinyl
RFTC	Heavy Duty Red Flap Tag Cover (V)	3½"	7¼"	• 10 mil Satin Vinyl



STCP



HSTC



HTBZL1



RFTC

HOLE PUNCHES

HOLE PUNCHES make a 1/8" or 1/16" round hole and come with clipping receptacles.

PART#	DESCRIPTION	HOLE SIZE	APPLICATIONS
HP1	Light Duty Hole Punch (1" Reach)	1/8"	Single Paper Tag, Label
HP116	Light Duty Hole Punch (1" Reach)	1/16"	Single Paper Tag, Label
HP2	Standard Hole Punch (2" Reach)	1/8"	Single Paper Tag, Label
HP3	Heavy Duty Hole Punch (2" Reach)	1/8"	Multiple paper, metal, and plastic tags, as well as molded service collars, etc.



VERIFICATION OF SERVICE COLLARS

Verification of Service Collars

Verification of Service Collars as required by NFPA 10. Made of durable flexible polyolith plastic this collar is available in four different sizes. Each size is a different colour for ease of identification. Printing is not affected by water.

PART#	DESCRIPTION	INSIDE DIA.
VSC1	Green, Pkg/100	1 3/8" ID
VSC2	Grey, Pkg/100	1 3/4" ID
VSC3	Blue, Pkg/50	2 1/8" ID
VSC4	Purple, Pkg/50	3" ID



Plastic Verification of Service Collars

Plastic Verification of Service Collars comply with NFPA 10. Made of durable polymer material, this collar is available in four different sizes. Each size is a different colour for ease of identification. NOTE: Collars read "Verification of Service, YR XXXX-XXXX" and "MN 1-12". Two smallest sizes have two years molded; larger ones have four.

PART#	DESCRIPTION	INSIDE DIA.
VSCP1	Plastic, Green, Pkg/100	1 3/8" ID
VSCP2	Plastic, Grey, Pkg/100	1 3/4" ID
VSCP3	Plastic, Blue, Pkg/50	2 1/8" ID
VSCP4	Plastic, Purple, Pkg/50	3 1/16" ID



Custom Verification of Service Collars

Custom-imprinted Verification of Service Collars comply with NFPA 10 and are made of high-density polyethylene with clear polyester over lamination. They are available in four sizes with your company name and phone number imprinted in durable coloured ink on white backgrounds. Other custom imprints available (as required by state). Normal delivery is 2-4 weeks. \$100 minimum order, but custom collar sizes can be mixed to achieve the minimum.

PART#	DESCRIPTION	INSIDE DIA.
SSPCC1	Custom, Green, Pkg/100	1 3/8" ID
SSPCC2	Custom, Grey, Pkg/100	1 3/4" ID
SSPCC3	Custom Blue, Pkg/50	2 1/8" ID
SSPCC4	Custom, Purple, Pkg/50	3 1/16" ID



- **SERVICE EQUIPMENT**



HOLE PUNCHES

HOLE PUNCHES make a 1/8" or 1/16" round hole and come with clipping receptacles.

PART#	DESCRIPTION	HOLE SIZE	APPLICATIONS
HP1	Light Duty Hole Punch (1" Reach)	1/8"	Single Paper Tag, Label
HP116	Light Duty Hole Punch (1" Reach)	1/16"	Single Paper Tag, Label
HP2	Standard Hole Punch (2" Reach)	1/8"	Single Paper Tag, Label
HP3	Heavy Duty Hole Punch (2" Reach)	1/8"	Multiple paper, metal, and plastic tags, as well as molded service collars, etc.



TAG COVERS AND TAG FASTENERS

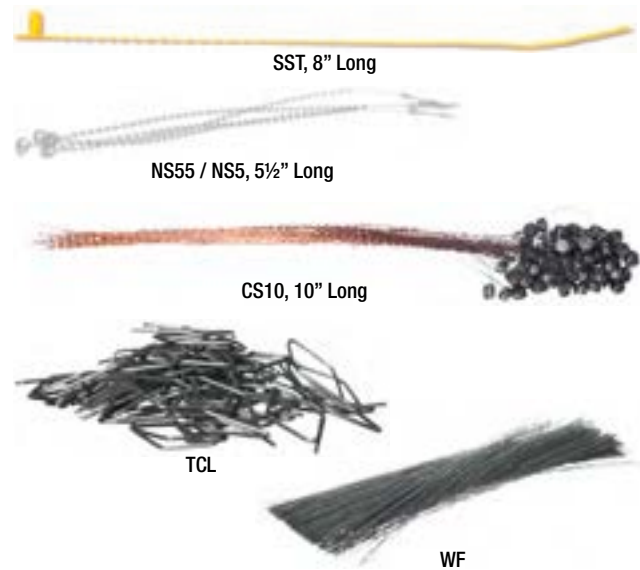
TAG COVERS are perfect for keeping dust and water away from your tags. Reliable, strong and will not crack.

PART#	DESCRIPTION	W	H	SPECS
STCP	Standard Tag Cover	3 3/16"	6 5/8"	• 2.5 mil Poly Plastic
HSTC	Heavy-Duty Tag Cover (V), Large	3 3/4"	7 1/4"	• 10 mil Frosty Matte Soft Vinyl • Withstands temperatures of -40°F to +130°F
HSTC2	Heavy-Duty Tag Cover (V), Small	3 1/8"	6 1/2"	• 10 mil Frosty Matte Soft Vinyl • Withstands temperatures of -40°F to +130°F
HTBZL1	Resealable Tag Cover (V)	3 3/8"	6 3/4"	• 10 mil Satin Vinyl
RFTC	Heavy Duty Red Flap Tag Cover (V)	3 5/16"	7 1/16"	• 10 mil Satin Vinyl



TAG FASTENERS available in different sizes and materials.

PART#	DESCRIPTION
SST	8" Yellow Secure-A-Seal, 2000/Box
NS55	5 1/2" Nylon Tag Seal, 5000/Box
NS5	5 1/2" Nylon Tag Seal, 1000/Pkg
CS10	10" Copper Wire with 1/4" Lead Seal, 100/Pkg
TCL	Diamond Tag Fastener Clip, 1000/Box
WF	12" Galvanized Tag Wire, 1000/Pkg



TAMPER SEALS

DATED TAMPER SEALS

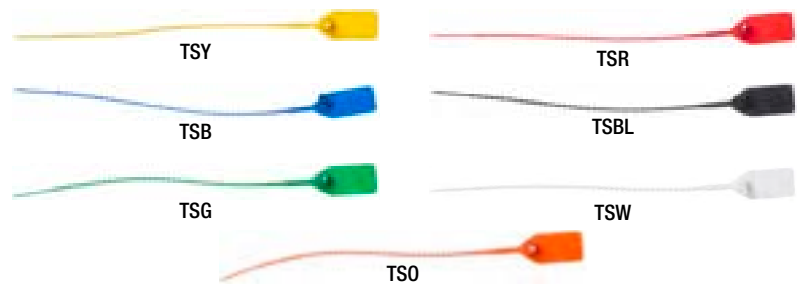
FLAME® DATED TAMPER SEALS are UL recognized components for fire extinguishers and available in many color combinations. Dated with the current year (shows seal has been replaced during annual maintenance, according to NFPA 10). Measures 9" long. Sold in bags of 500 (50 matted sheets of 10 each). Seals break under 15 ft lbs per UL guidelines. **Ordering information: Replace the XX with the two-digit year code.**

PART#	DESCRIPTION
FLMRW-XX	Flame® Dated Tamper Seal, Red w/ White Imprint
FLMYBK-XX	Flame® Dated Tamper Seal, Yellow w/ Black Imprint
FLMBW-XX	Flame® Dated Tamper Seal, Blue w/ White Imprint
FLMBKGD-XX	Flame® Dated Tamper Seal, Black w/ Gold Imprint
FLMWB-XX	Flame® Dated Tamper Seal, White w/ Blue Imprint
FLMGW-XX	Flame® Dated Tamper Seal, Green w/ White Imprint
FLMWR-XX	Flame® Dated Tamper Seal, White w/ Red Imprint



DATED MEDIUM TAMPER SEALS are UL recognized components for fire extinguishers. Available in seven colors, they come dated (current year) to show seals have been replaced during annual maintenance (in accordance with NFPA 10). Measures 9". Sold in bags of 500. Seals break under 15-ft lbs per UL guidelines. **Ordering information: Replace the XX with the two-digit year code.**

PART#	DESCRIPTION
TSY-XX	Medium Date Tamper Seal, Yellow
TSR-XX	Medium Date Tamper Seal, Red
TSB-XX	Medium Date Tamper Seal, Blue
TSBL-XX	Medium Date Tamper Seal, Black
TSG-XX	Medium Date Tamper Seal, Green
TSW-XX	Medium Date Tamper Seal, White
TSO-XX	Medium Date Tamper Seal, Orange

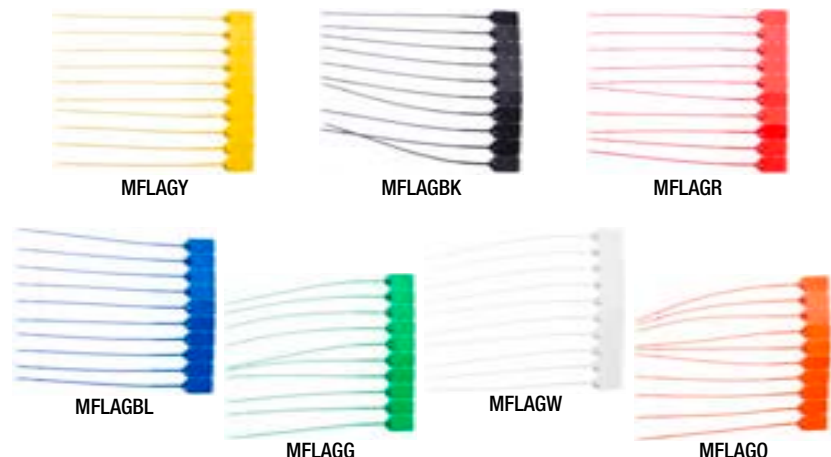


CUSTOM TAMPER SEALS available with your Company Name/Logo. Minimum of 10,000 seals. These seals are a UL recognized components for fire extinguishers. Available in seven colors, they come dated (current year). Measures 9". Sold in bags of 500 (50 matted sheets of 10 each). Seals break under 15-ft lbs per UL guidelines.

DATELESS TAMPER SEALS

DATELESS MEDIUM-MATTED TAMPER SEALS are UL recognized components for fire extinguishers. Available in seven colors. Measures 9". Sold in bags of 500 (50 matted sheets of 10 each). Seals break under 15-ft lbs per UL guidelines.

PART#	DESCRIPTION
MFLAGY	Medium-Matted Tamper Seal, Yellow
MFLAGBK	Medium-Matted Tamper Seal, Black
MFLAGR	Medium-Matted Tamper Seal, Red
MFLAGBL	Medium-Matted Tamper Seal, Blue
MFLAGG	Medium-Matted Tamper Seal, Green
MFLAGW	Medium-Matted Tamper Seal, White
MFLAGO	Medium-Matted Tamper Seal, Orange



DATELESS TAMPER SEALS CONTINUED

BULL'S EYE TAMPER SEAL are a UL recognized component for fire extinguishers. Available in three colours. Sold in bags of 500 (50 matted sheets of 10 each) and measures 9" long. Seals break under 15-ft lbs per UL guidelines. **Not Dated.**

PART#	DESCRIPTION
PT7Y	Bull's Eye Tamper Seal, Yellow
PT7R	Bull's Eye Tamper Seal, Red
PT7B	Bull's Eye Tamper Seal, Blue



PT7Y

PT7R

PT7B

AEROSOLS AND LUBRICANTS

Brooks Sign On, Lube & Crazy Kleen

Brooks sign on **ADHESIVE** bonds signs to almost anything. Great for porous surfaces!

PART#	DESCRIPTION
BA1	Brooks Sign On Aerosol



BA1

Brooks **LUBE** made for the fire extinguisher industry. Lubricates, cleans, penetrates and protects parts.

PART#	DESCRIPTION
BA2	Brooks Lube Aerosol



BA2

Brooks Crazy Kleen **MULTI-PURPOSE INDUSTRIAL STRENGTH CLEANER**. Use it in the shop, on the trucks and at home.

PART#	DESCRIPTION
BA4	Brooks Crazy Kleen Aerosol



BA4

WD40 loosens Rusted Parts. WD40 frees sticky mechanisms and penetrates to free up frozen or rusted metal parts and fasteners. WD40 keeps controls and linkages working freely.

Displaces moisture. WD40 gets under water, drives it off and keeps it off. WD40 is a non-conductor and can be used to dry out electrical and electronic equipment.

Stops Squeaks. WD40 finds and lubricates squeaks in hard-to-get-at mechanisms. WD40 is silicone-free, which means no messy, gummy residue.

Protects metal. WD40 lubricates and protects against moisture and corrosive elements.

PART#	DESCRIPTION
WD1011	11 oz. can
WD10	3.785 litres



WD1011



WD40 – THERE IS ALWAYS ANOTHER USE.



WD10

Lift Off® ADHESIVE REMOVAL effectively removes adhesives, chewing gum, grease, tar, and motor oil. 10.5 oz aerosol.

PART#	DESCRIPTION
LOAR	Lift Off Adhesive Removal



LOAR

FUNNELS, SCOOPS AND AIR HOSE

FILLING FUNNELS made of durable galvanized steel with two different heavy duty mesh screens properly sized and spaced. These screens eliminate clogging and jamming of the funnel allowing the chemical to flow through in a liquid state. Comes in 3 different sizes.

PART#	DESCRIPTION
FF1	Small Funnel 15½" x 6" Dia. x ¾" O.D. Tip
FF2	Large Funnel 13½" x 10" Dia. x 1⅛" O.D. Tip
FF3	Large Neck Funnel 10½" x 10" Dia. x 2¼" O.D. Tip



METAL FILLING SCOOPS for filling dry chemical fire extinguishers.

PART#	DESCRIPTION
NAS1	Small Filling Scoop, ¾ Quart/ 24 oz. Volume
NAS2	Large Filling Scoop, 1.18 Quart/ 38 oz. Volume



Aluminum **PAIL OPENER** for opening dry chemical pails quick and easy. Does not ruin lid.

PART#	DESCRIPTION
PLO	Pail Opener



BLOW GUN set-up for blowing out valves, cleaning work area, etc.

PART#	DESCRIPTION
SBG1	Safety Blow Gun
CON1	¼" Connector
QDC	Quick Disconnect Coupler
AC1	Air Chuck
AVA	Air Valve with Cap



COILED AIR HOSE are for blowing out valves, cleaning off work areas, etc. CH models are permanently coiled hoses, made from abrasion resistant nylon and fitted with brass fittings. Hoses come standard with ¼" NPT(M) fittings on both ends. Rated at 200 PSI. Note: Do not use for recharge line.

PART#	DESCRIPTION
CH12	12 ft Coiled Air Hose
CH25	25 ft Coiled Air Hose



AIR HOSE REELS are long lasting thanks to the top-quality materials that go into making them. The AHR33 is constructed from impact-resistant polypropylene, plus 33' of ¼" ID polyurethane mesh hose. There's also a swivel bracket that allows the AHR33 to be mounted in multiple locations. The AHR49 is even tougher - made of steel that's covered in a corrosion-resistant powder coating for extra-long life. It comes with 49' of ⅜" rubber hose. And, the AHR49 includes a multiposition ratchet lock, tension adjustment and a fullflow swivel that prevents leakage. A guide arm also cuts down on hose wear and tear, plus with nine adjustable positions, the reel can be mounted on the ceiling, floor or wall.

PART#	DESCRIPTION	DIMENSIONS
AHR49	Air Hose Reel, 49' Hose	19" X 8" X 20"



NITROGEN REGULATOR AND ACCESSORIES

NITROGEN REGULATOR set-up for recharging of extinguishers. Regulator has a spring type (re-seating) safety relief, CGA580 inlet connection, 1/4" NPT female outlet, high strength rubber diaphragm and a rugged all metal body. Comes with part number NITA and a one year factory warranty. Outlet pressure 0-500 PSI. Hose not included.

PART#	DESCRIPTION
NR600	Nitrogen Regulator w/NITA (hose not included), DOT, TC Certified
NH10	10' High Pressure Nitrogen Hose
4000G	4000 PSI Replacement Gauge for NR600 Regulator
1000G	1000 PSI Replacement Gauge
NITA	Nitrogen Valve to Regulator Adapter
C02	1/4" F x 1/4" F CO2 Coupling



SCALES

HANGING SCALES are accurate and dependable with adjustable pointers and heavy duty steel construction.

PART#	DESCRIPTION
DHS9901	Digital 99 lbs. x 10 oz. Hanging Scale
501	50 lbs. x 1 lb. Hanging Scale



Cartridge hanging scales that are compact and portable.

PART#	DESCRIPTION
401	4 lbs. x 1 oz. Hanging Scale
605	60 oz. x 1/2" Hanging Scale special Order
SCLIP	CO2 and Nitrogen Cartridge Scale Clip



Adjustable Spring Dial Platform scales for weighing extinguishers during recharge. Corrosion resistant, shatter proof window, and easy to use. Comes with zero adjustment knob.

PART#	DESCRIPTION
T100	100 lbs. x 4 oz. Fixed Spring Platform Scale
T40	40 lbs. x 2 oz. Adjustable Spring Dial Scale



Heavy duty **UTILITY SCALE** with 18 gauge steel case, memory lock, carrying handle, zero adjustment knob and reinforced rib platform.

PART#	DESCRIPTION
US250	250 lbs. x 1 lb. Utility Scale



ELECTRONIC DIGITAL SCALES for cartridge filling and inspection. Features 4 lbs. x 0.1 oz or 2000 gram x 2 gram capacity. Features tare, LCD digital display, automatic shutoff and made of high impact styrene construction. Operates on either a 9V battery or AC adapter (both sold separately). Measures 5" x 6 1/2" x 1 1/2" with a 5 15/16" x 4 3/4" platform.

PART#	DESCRIPTION
DKS3002	4 lbs. x 0.1 oz. Electronic Digital Scale



This **LEGAL-FOR-TRADE PORTION SCALE** is perfect when fast and easy portion control is required. Incorporating a portable wireless design, these scales feature over/under check weighing, removable stainless steel platforms, and adjustable auto shut offs. An automatic/semi-automatic zero-setting mechanism is standard. Scales operate on four D-cell batteries or an AC adapter (both sold separately).

PART#	DESCRIPTION
LTDS60	Legal-For-Trade 60 lb x 0.02 lb Digital Scale (4 D-Cell)
LTDSAC60	AC Adapter (For 60 lb Scale)



LTDS60

RECHARGE EQUIPMENT

This **3-WAY VALVE** provides an easy and safe method of venting pressure when charging dry chemical and other low-pressure fire extinguishers. After reaching the correct extinguisher pressure and installing the extinguisher's pull pin, a half turn of the 3-way valve handle instantly bleeds off the pressure between the **3WV** and the extinguisher (with minimal loss of nitrogen) for safe removal of the quick disconnect (**QDC**). Use the **4HN** nipple to attach the quick disconnect. Maximum pressure is 500 psi.

PART#	DESCRIPTION
3WV	3-Way ¼" Valve
4HN	¼" M x M Hex Nipple for 3-Way Valve
QDC	Quick Disconnect Coupler



RUBBER MALLETS

PART#	DESCRIPTION
RM16	16 oz. Rubber Mallet



RM16

POURING BAGS FOR PAILS Controls flow of powder, helps keep dust down, easier to fill hoppers.

PART#	DESCRIPTION
PAILBAG	For Transferring Powder from Pails



PAILBAG

DISPOSAL COMFORT MASK for relief from nuisance and non-toxic dusts, powders and pollen. Lightweight with adjustable elastic head strap and metal forming strip over nose for comfort.

PART#	DESCRIPTION
RP9500	Disposable Dust Mask (Box of 50)



MASK

BLOW OUT BAG empties extinguishers in seconds without a mess saving time and money. Easy to use, place nozzle or hose into neck of bag, hold securely, release pressure slowly until empty. Velcro sealed across bottom making it easy to empty.

NOTE: DO NOT MIX CHEMICALS! NOT RECOMMENDED FOR RECLAIMING CHEMICALS.

PART#	DESCRIPTION
BBAG	Blow Out Bag



BBAG

FireTech's® EZ FILL SIPHON is not only easy but fast – transferring up to 3½ gallons of liquid per minute. The 6' clear hose is durable, flexible, non-toxic, and has a copper nipple that's anti-static and anti-spark for safety. Use to transfer liquids, including fuels oils, water, paint, and more. To operate, make sure the liquid to be transferred is higher than the empty container. Submerge the **EZ FILL SIPHON** and shake it to start the transfer.

PART#	DESCRIPTION
EZFILL	EZ Fill Siphon



EZFILL

CO2 RECHARGE EQUIPMENT

CO2 CHARGING

CO2 CHARGING LINE COMPONENTS

PART#	DESCRIPTION
C01D	1/2" F x 1/4" F CO2 Coupling
C02	1/4" F x 1/4" F CO2 Coupling
FWSN	Fiber Washer for Swivel Nut (Pkg. of 25)
C014P	Nylon "Snap In" Washer (Pkg. of 50)
*CA125	1/8" F x 1/2" M CO2 Charging Adapter
CA225	1/4" F x 1/2" M CO2 Charging Adapter
CA375	3/8" F x 1/2" M CO2 Charging Adapter
C011	1/2" F x 1/2" M CO2 Coupling
C012	1/2" F Plastic Hand Nut
C013	2 1/2" Brass Nipple
FV25	Flip Valve 1/4" F x 1/4" F
F72194	Valve Stem
FVH	Flip Valve Handle
C016	5 lb. CO2 Charging Adapter (Amerex 5lb. CO2)
C017	Brass Swivel Nut
C03	6' Charging Hose 1/4" M x 1/4" M
COC6	CO2 Charging Unit As Shown NOW WITH 2 FLIP VALVES
VHG	Valve Handle Grip for holding squeeze handle type valves in the open position

*Not Shown

NOTE: The shown adapters and components are only a partial list of items and equipment needed to safely refill carbon dioxide cartridges and cylinders. These adapters and components should be purchased and used **ONLY** by personnel who are thoroughly familiar with and understand the standards published in the Compressed Gas Association pamphlets G-6 and S-1.1, Code of Federal Regulations Title 49, Parts 100 thru 185 and who have received "hands-on" training under the direct supervision of someone experienced in cartridge refilling. If you lack the knowledge training or experience described above, do not attempt to refill carbon dioxide cartridges or cylinders. Instead, we recommend that you purchase either new cylinders and cartridges or have them refilled by an established service facility. **Failure to adhere to the above instructions could result in serious injury or death!**

CO2 CARTRIDGE RECHARGE EQUIPMENT

PART#	DESCRIPTION
CRA2	CO2 Cartridge Recharge Assembly As Shown (Does not include Bonnet & Stem)
RS81LH	Filling Bonnet for Ansul & General D/C CO2 Cartridge Extinguisher
RS82RH	Filling Bonnet for use with Ansul Systems Cartridge
OR211	O-Rings for Bonnets
RS87	Bushing Tool for use with Bonnets
OR111	O-Ring for RS87 Stem

Master Metallic Compound for use on metal or plastic pipe. MMC prevents leaks, withstands pressure well above 6,000 PSI and temperatures up to 700°F. It seals against leakage of air, water, steam, gasoline and oils, natural or manufactured gases and almost all chemicals. **INCLUDES BRUSH APPLICATOR IN TOP.**

PART#	DESCRIPTION
MC2	Fire Extinguisher & Cylinder Valving Sealing 2 lb. Can Compound & Pipe Thread Sealing Compound

PAINTBALL RECHARGE KIT

Specially designed for paintball cylinders, this new **RECHARGE KIT** features a single 1,000 PSI WOG CO² brass ball valve and CO² pin depressor for safe filling and handling. **Warning:** This kit is for refilling paintball cylinders only. A scale must be used to insure a safe fill. For indoor use only.

PART#	DESCRIPTION
PBRKIT	Paintball Cylinder Recharge Kit



DRY CHEMICAL RECHARGE ADAPTERS, AIR VALVES AND QUICK DISCONNECT COUPLERS

Fire extinguisher **RECHARGE ADAPTERS**, air valves and quick disconnect couplers.

PART#	DESCRIPTION
RA11	Recharge Adapter (Amerex, Ansul, Badger, General, Pyrene, Strike, Diamond all, Buckeye, Flag 10-30 lb & New Pyrene), Stamped with AD24
RA16	Recharge Adapter (Amerex, Amerex A Vlv, Badger, General, Old Kidde, Flag 5 lb, New Pyrene), Stamped with AD21
RA36	Recharge Adapter (Amerex 270, 272, B260, B262), Stamped with AD36
A9492	Recharge Adapter (Amerex High Perf Models)
AD38*	Recharge Adapter Ansul Sentry 2.5 lb Model A02S, A02SVB, Stamped with AD38
RA12	Recharge Adapter (Ansul Sentry 2.5 lb. & 5 lb. Coarse Thread - Small Valve), Stamped with AD22
AS440623	Recharge Adapter (Ansul Sentry 2.5-20lb-Year 2013+)
RA30	Recharge Adapter (All Ansul Sentry Units Except 2.5lb-Large Valve), Stamped with AD30
RA20	Recharge Adapter (Ansul, Buckeye, Pyrene 10 - 20 lb PDL Models, Kidde-Large Pro Line Units), Stamped with AD23
R04646	Recharge Adapter (Badger Extra Small Valve)
B4795	Recharge Adapter (Badger Extra Large Valve)
RA13	Recharge Adapter (Old Style Kidde Units), Stamped with AD25
RA17	Recharge Adapter (RC Ind. (Clip Type Nozzle), Stamped with AD26
RA19	Recharge Adapter (Kidde Nylon Valve with Nozzle), Stamped with AD27
RA14SET	Recharge Adapter (Fyr-Fyter, Buffalo, C-O-Two, Pyrene & Norris), Stamped with AD29
CON2	Male Quick Disconnect, 1/8"
RA22	Recharge Adapter (Kidde Nylon Valve w/Hose), Stamped with AD32
RA15	Recharge Adapter (Kidde Coarse Thread), Stamped with AD34
RA35	Recharge Adapter (Kidde Pro Line-Small Units, New Ansul Sentry), Stamped with AD35
RA10	Discharge Adapter (Badger & American LaFrance), Stamped with AD28
RASET	Complete Set of Recharge Adapters – 11, 12, 13, RA14SET, 15, 16, 19, 20, 22, 30, 35, 36, AS440623
KC02*	Kidde CO2 System Recharge Adapter cw/ OR110
AC1	Air Chuck
AVA	Air Valve with Cap
QDC	Quick Disconnect Coupler
CORE	Replacement Core for AVA, Pkg. of 50
DCA	Discharge Adapter for Cartridge Receiver (Left Hand Thread)
CRT	Core Removal Tool
F550130*	Recharge Adapter (Flag 10-30 lb H Models)

*Not Shown



Discontinued

RECHARGE ADAPTER KIT contains 14 recharge adapters (RA11, RA12, RA13, RA14SET, RA15, RA16, RA19, RA20, RA22, RA30, RA35, RA36, AS440623), 12 each CON2, 1 each QDC, CON1 and AC1 in a yellow parts box with a full scale illustration of each.

PART#	DESCRIPTION
RAKIT	Recharge Adapter Kit

**A RECHARGE KIT IS AVAILABLE FOR
GARRISON EXTINGUISHERS
SOLD IN CANADIAN TIRE STORES ON REQUEST**



HYDROTEST ADAPTERS

LOW PRESSURE HYDROTEST ADAPTERS

LOW PRESSURE HYDROTEST ADAPTERS for Portable Extinguishers and Restaurant System Cylinders.

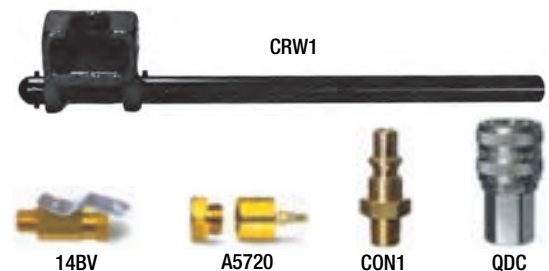
PART#	DESCRIPTION
HTAA1	Hydrotest Adapter (Amerex, 5-20 lb brass valve, Badger & American LaFrance, Ansul 2.5-5 lb Small Valve, Pyrene PW HW16P)
HTAA2	Hydrotest Adapter (Amerex, Ansul, Badger General & Kidde Pressure Water)
HTAA3	Hydrotest Adapter (Amerex A Series & Ansul 2.5-5 lb. Small Valve)
A4892	Hydrotest Adapter (Cylinder Hose Opening for Amerex DC Wheeled Units)
HTA43	Hydrotest Adapter (Ansul Sentry)
HTA46	Hydrotest Adapter (Ansul Water & Wet Chemical Extinguishers)
HTAAN5	Hydrotest Adapter (Ansul, 5 lb. Cartridge Operated)
HTAAN10	Hydrotest Adapter (Ansul & General Cartridge Operated 10, 20 & 30 lb)
HTA12D	Hydrotest Adapter (Ansul Cartridge Operated Cylinder Only)
B21007876	Hydrotest Adapter (Badger Advantage) (Requires OR212 Sold Separately)
HTA44	Hydrotest Adapter (Badger Extra & American LaFrance, Large Valve)
HTA45	Hydrotest Adapter (Badger Extra Models 5 lb, Small Valve)
HTAB1	Hydrotest Adapter (Badger & American LaFrance, Older Models with 2 $\frac{5}{8}$ " Neck)
HTABU1	Hydrotest Adapter (Buckeye, All General Older Small Valve, Diamond & Strike 5-30 lb, Flag 10-20 lb)
HTAF4	Hydrotest Adapter (Flag PWS 25 F & Dry Chem PDC Models w/Fine Thread)
HTAF5	Hydrotest Adapter (Flag PWS 25 4 & Dry Chem PDC Models w/Coarse Thread)
HTAF1	Hydrotest Adapter (General 2.5-5 lb J, JH, LH Series & Flag 5 lb)
HTAG1	Hydrotest Adapter (General Older Models with 3 $\frac{1}{4}$ " Neck)
HTAG2	Hydrotest Adapter (General PW WS 800B, LS800 B Models with 2 $\frac{1}{16}$ " Neck)
HTAG4	Hydrotest Adapter (General Dry Chemical 10, 20, 30 lb A, B, D, E Series)
HTAK1	Hydrotest Adapter (General & Kidde Small Valve, Diamond All, Strike all, Flag 10-20 lb)
HTAK4	Hydrotest Adapter (Kidde Older Dry Chem Models)
HTAK5	Hydrotest Adapter (Kidde LSPS, WPSW Pressure Water)
HTAK6	Hydrotest Adapter (Kidde PW, WPPN)
HTAK8	Hydrotest Adapter (Kidde 2.5- 6 lb Plastic Valve & Proline)
HTAK39	Hydrotest Adapter (Kidde 10 lb. RAP & TAP Plastic Valve)
HTASF2	Hydrotest Adapter (Strike First $\frac{7}{8}$ " valve-2.5 & 2.75 lb)
HTAFF2	Hydrotest Adapter (Old-Style Range Guard Systems & Fyr-Fyter Systems)
HTA41	Hydrotest Adapter (Pyro Chem Wet Systems)
HTA42	Hydrotest Adapter (Ansul R-102 System w/Internal Threads, UL300 Stainless Steel Cylinder)
HTAK3	Hydrotest Adapter (Kidde System & PyroChem Systems)
1G0249	Adapter to use HTA's with Getz Hydrostatic Test Equipment



**SEE MANUFACTURERS PICTOGRAMS
PG. 200 - 255, ACCESSORIES, FOR
CORRECT HYDROTEST ADAPTOR**

ACCESSORY PARTS for Portable Extinguishers and System Cylinders.

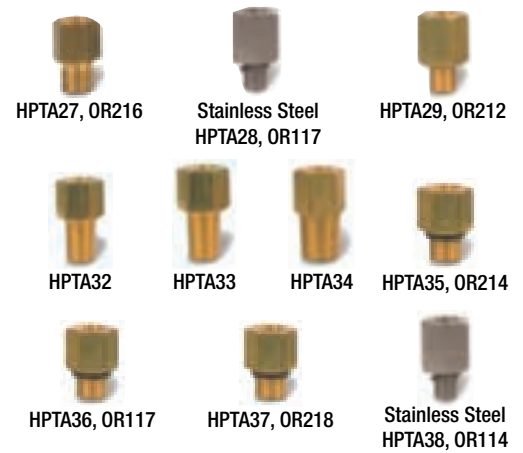
PART#	DESCRIPTION
CRW1	Ansul Wrench for Cartridge Receiver D & E Models
14BV	Miniature Ball Valve ($\frac{1}{4}$ " Pipe Thread)
A5720	Hydrotest Adapter for CEH75
CON1	$\frac{1}{4}$ " Male Quick Disconnect for HTA (except HTA41)
QDC	Quick Disconnect Coupler



HIGH PRESSURE HYDROTEST ADAPTERS

HIGH PRESSURE HYDROTEST ADAPTERS TO BE USED IN WATER JACKET HIGH PRESSURE TEST UNITS.

PART#	DESCRIPTION
HPTA27	1½" UNF, Aluminum Cylinders & Extinguishers (Amerex, Ansul, Badger, Diamond, Flag)
HPTA28	¾" UNF, Scott Air Cylinders-II & Aluminum ICC 2015, Sportsway Dive Tanks & Others O-Ring Groove, Stainless Steel
HPTA29	7/8" UNF, Scott Air Cylinders-III & Others
HPTA32	½" NGT, Commercial Gas Cylinders & CO2 Extinguisher
HPTA33	¾" NGT, Commercial Gas Cylinders & CO2 Extinguisher
HPTA34	1" NGT, Commercial Gas Cylinders & CO2 Extinguisher
HPTA35	¾" Straight Pipe, Dlve, Scuba & Aqua Tanks
HPTA36	½" Straight Pipe, MSA & Others
HPTA37	1¼" UNF, Aluminum Cylinders & Extinguisher
HPTA38	¾" UNF, MSA, FRP & Others w/o O-Ring Groove, Stainless Steel



CARTRIDGE TEST ADAPTERS

High pressure hydrostatic **CARTRIDGE TEST ADAPTERS**. For cartridges with a diameter of 2" & over.

PART#	DESCRIPTION
HTAN1	Left-Hand Thread High Pressure Test Adapter for Ansul & General Cartridges, Flag & Pyrene
HTAN2	Right-Hand Thread High Pressure Test Adapter for Ansul & General Cartridges, Flag & Pyrene



STAMP HOLDER AND STAMPS

TOOL HOLDER for holding steel stamps when stamping test dates. Saves fingers from being damaged. Will hold many other tools.

PART#	DESCRIPTION
HSH	Tool Holder



STEEL STAMP are manufactured to meet the most demanding industrial applications with an extra-heavy, extra-long shank and supporting bevel. They feature character identification, size, three thumb grooves and cut ¼" numbers

PART#	DESCRIPTION
SSSET	Steel Stamp Set
MS0	Number 0 Steel Stamp
MS1	Number 1 Steel Stamp
MS2	Number 2 Steel Stamp
MS3	Number 3 Steel Stamp
MS4	Number 4 Steel Stamp
MS5	Number 5 Steel Stamp
MS6	Number 6 & 9 Steel Stamp
MS7	Number 7 Steel Stamp
MS8	Number 8 Steel Stamp



SS SET

PARTS BIN BOX. Great for storing o-rings, rivets, fusible links, etc.

PART#	DESCRIPTION
LBOX	Parts Bin Box (Large)



LBOX

CONDUCTIVITY, CYLINDER AND HYDROTEST LABELS

Metallic **CONDUCTIVITY TEST LABELS**. Bilingual. 100 per roll.

ONE WEEK DELIVERY

PART#	DESCRIPTION	W X H
CUCTL2	Custom Conductivity Test Label with Customer Name	3" x 3/4"
CTL2	Blank Conductivity Test Label	3" x 3/4"



CUCTL2

COMPOSITE CYLINDER TEST LABELS meet the requirements of Transport Canada for recording test information on composite cylinders. Sold per pkg of 50. Use our **5 MINUTE EPOXY** for applying over the composite test labels.

PART#	DESCRIPTION	Dia.
CRL50	Composite Cylinder Test Labels, Sold 50/pkg	2 1/2"
5ME	5 Minute Epoxy	



CRL50



5ME

BRUSHES

BRUSHES for cleaning valves, threads, etc.

PART#	DESCRIPTION
VCB	Metal Bristle Cleaning Brush
BVCB	Brass Bristle Cleaning Brush for Aluminum
NB	Nylon Bristle Cleaning Brush
TB	Tooth Brush
NWB	Nylon Cleaning Brush
BWB	Brass Cleaning Brush
WB	Nylon Wire Brush
CWB	Industrial Grade Wire Brush



VCB

BVCB

NB

TB

NWB

BWB

WB

CWB

FASTENERS

E-Z ANCHOR self drilling fastener requires no predrilling. Installs easily using a Phillips screwdriver, no other tools needed. Doesn't leave those big gaping holes when removed. Deep thread engagement for strength in 3/8" to 5/8" wallboard (sheetrock). Works with #8 screw (**no longer included**).

PART#	DESCRIPTION
EZP	Metal Self Drilling Anchor 100/pkg (screws not included)



EZP

METAL E-Z ANCHORS

E-Z TOGGLE self drilling toggle bolt requires no predrilling. Installs easily using a Phillips screwdriver, no other tools needed. Doesn't leave those big gaping holes when removed. Unique patented clamp replaces both 1/8" and 3/8" winged toggles. Deep thread engagement for strength in 3/8" to 5/8" wallboard (sheetrock).

PART#	DESCRIPTION
EZTOG	E-Z Toggle complete with screws, Pkg. of 50



EZTOG

TAPCON SELF TAPPING CONCRETE ANCHORS are the fastest way to secure wall brackets and cabinets to concrete. Just drill pilot hole and screw it in! No plastic or metal plugs needed, cuts its own threads into masonry. Holds strong in block, brick or poured concrete. Use the Condrive tool for easy installation.

PART#	DESCRIPTION
TAPCON	Tapcon Self-Tapping Anchors, Pkg. of 100 (1 Drill Bit included)



TAPCON

SELF DRILLING STEEL FASTENERS will self tap into ¼” to ½” steel. No drilling needed! Hex head #12 x 1¼” long milled self driller. A non-walking point with precise cutting edges and its unique design increases drilling performance and requires less end pressure.

PART#	DESCRIPTION
SA1	Self-Drilling Fastener, Pkg. of 100



SA1

TEFLON TAPE

PART#	DESCRIPTION
T480	Teflon Tape (½” x 480”)



T480

TEFLON TAPE

GAUGE SERVICE EQUIPMENT

Pressurized water extinguisher **GAUGE TESTER** allows you to check gauge while unit is pressurized. Can also be used as a tire gauge. Rugged bronze bourdon tube and brass movement. Holds pressure until released. Complete with operating instructions.

PART#	DESCRIPTION
PWGT	Gauge Tester for Pressurized Water Extinguisher



PWGT

BUBBLES LEAK DETECTOR adheres to overhead surfaces and leaves no residue, dries clean and clear. Best way to check for gauge leaks! Patented self storing “Squirtubes” have small bores for dispensing small quantities. OK for CO2 nitrogen and halon. Meets MIL-L-25567BC specification.

PART#	DESCRIPTION
LD1	8 oz. Squirt ‘n Bubbles Leak Detector



LD1

GAUGE WRENCH made of steel and fits most gauges.

PART#	DESCRIPTION
GWRENCH	Gauge Wrench



GWRENCH

TOOLS

CYLINDER INSPECTION

CYLINDER INSPECTION LIGHTS are great for inspecting the inside of cylinders. Both come with a protective cover that can be used as an extension, flexible shaft that can be bent to desired angle. Batteries included. The Krypton bulb will fit in either light.

PART#	DESCRIPTION
24CIL	24” Cylinder Inspection Light (Krypton Lamp)
16CIL	16” Cylinder Inspection Light (Standard Lamp)
110KRP	Krypton Replacement Bulb (Not Shown)
100STD	Standard Replacement Bulb (Not Shown)



24CIL



16CIL

INSPECTION MIRROR which telescopes from 5⅝” to 19½” and features an adjustable 7/8” Dia. mirror and magnetic end. The end is magnetized for retrieving those lost items from hard to reach areas and comes with pocket clip.

PART#	DESCRIPTION
IM	Inspection Mirror



IM

PLIERS

CHANNELLOCK® TONGUE AND GROOVE PLIERS feature right angle teeth to grip in all directions, undercut tongue and groove for adjustments that won't slip, reinforcing edge that minimizes stress breakage and PERMALOCK® fastener to eliminate nut and bolt failure.

PART#	DESCRIPTION
*TL440	12" Tongue and Groove Pliers
*TL442	12" Curved-Jaw Tongue and Groove Pliers
TL420	9½" Tongue and Groove Pliers
TL426	6½" Tongue and Groove Pliers



TL420



TL426

*Not Shown

PLIERS features perfectly mated cutters, heat treated to hold their edge and polished high carbon drop forged steel construction. CHANNELLOCK® slip joint pliers feature a wire cutting shear and PERMALOCK® fastener to eliminate nut and bolt failure. All pliers feature CHANNELLOCK BLUE® comfort grip handles.

PART#	DESCRIPTION
TL317	7½" Long Nose Pliers w/cutter
TL526	6" Slip Joint Pliers



TL317



TL526

WISE-GRIP® LOCKING PLIERS can be used for turning, cutting, tightening, clamping and twisting. Features hardened tooth design to grip from any angle, adjusting screw for exacting pressure and hold for repetitive use. Constructed of alloy steel and heat treated for toughness and durability. Pliers TLVG1 and TLVG3 feature a built-in wire cutter that cuts up to a ¼" bolt.

PART#	DESCRIPTION
TLVG1	7" Curved Jaw Vise-Grips® w/ Wire Cutter
TLVG2	7" Straight Jaw Vise-Grips®
TLVG3	6" Long Nose Vise-Grips® w/ Wire Cutter



TLVG1



TLVG2



TLVG3

CHANNELLOCK® LOCKNUT PLIERS are designed for quick, easy adjustment of electrical locknuts. Fits locknut sizes: ½", ¾", 1", 1¼", and 1½". The thin profile is ideal for use in tight/wire-confined electrical boxes. Spring-loaded handles lock for easy storage and the handle shape allows for both right- and left-handed use.

PART#	DESCRIPTION
TL960	Locknut Pliers



TL960

WRENCHES

TORQUE WRENCH (½" - 150 ft. lbs.) with dial in torque setting. Wrench indicates desired torque by feel and sound.

PART#	DESCRIPTION
TW	Reversible Ratchet Torque Wrench



VW1

SLIP JOINT VALVE WRENCH fits all manufacturer's CO2 valves. Makes de-valving easier with just one wrench needed. Made of heavy steel to last a lifetime.

PART#	DESCRIPTION
VW1	Slip Joint Valve Wrench



TW

CHANNELLOCK TOOLS

CHANNELLOCK® ADJUSTABLE WRENCHES feature chrome vanadium steel construction.

PART#	DESCRIPTION
TL806	6" Adjustable Wrench
TL810	10" Adjustable Wrench



TL806

TL810

Heavy-duty iron **PIPE WRENCHES** are cast from special steel alloy for long-lasting performance. Wrenches feature precision hardened, polished jaws and teeth for a tight grip on pipe.

PART#	DESCRIPTION
TL3912	12" Offset Pipe Wrench
TL3914	14" Offset Pipe Wrench



TL3914

MISCELLANEOUS TOOLS

CO2 HOSE CONTINUITY TESTER for testing the continuity of CO2 hoses per NFPA 10. **NOTE:** be sure to remove hose from extinguisher and place on non-conductive surface before testing.

PART#	DESCRIPTION
CHT	CO2 Hose Continuity Test (BATTERIES NOT INCLUDED)



CHT

CO2 HOSE CONTINUITY TESTER for testing the continuity of CO2 hoses per NFPA 10. This tester is a more rugged, pocket size tester than the CHT, no leads required. Complete with batteries. **NOTE:** be sure to remove hose from extinguisher and place on non-conductive surface before testing.

PART#	DESCRIPTION
NCHT	CO2 Hose Continuity Test



NCHT

O-RING REMOVAL KIT consists of the handle and four different tools in a handy vinyl storage pouch.

PART#	DESCRIPTION
ORRK	O-Ring Removal Kit



ORRK

WIRE CUTTER AND WIRING TOOL. Wire cutters feature perfectly mated cutters, heat treated to hold their edge and high carbon drop forged steel construction. Wiring tool features specially heat treated blades for long life. Both feature CHANNELLOCK BLUE® comfort grip handles.

PART#	DESCRIPTION
TL337	7" Wire Cutter
TL908	Wiring Tool



TL337



TL908

PERMANENT MARKING PENS for marking on metal, plastic, vinyl etc.

PART#	DESCRIPTION
PMP	Black Medium Permanent Marking Pen
UFMP	Black Extra Fine Permanent Marking Pen



PMP



UFMP
(SOLD PER PEN)

BUCKET TOOL MATE turns an empty bucket into a tool/supply carrier. Features 24 pleated pockets (17 outside-7 inside) leaving the center for larger bulky items like extension cords, drills, etc. Saves time by having all of your tools and supplies visible and within reach.

PART#	DESCRIPTION
JB24	Tool Mate 24 Pocket Carrier



JB24

The **LIGHTWEIGHT TOOL BELT** combines all features of expensive tool belts into one economical package. Engineered by professional tool users to hold the most widely used repair tools, this belt performs just like belts that cost two to three times more. Perfect for the extinguisher service person. No more loading your pockets with tags, punches, seals, rubber mallet, etc. Fully adjustable belt with quick release buckle. One size fits most! Tools not included.

PART#	DESCRIPTION
BELT1	Tool Belt



BELT1

PARTS BIN BOX. Great for storing o-rings, rivets, fusible links, etc.

PART#	DESCRIPTION
LBOX	Parts Bin Box (Large)



LBOX

HANDCARE PRODUCTS

HAND CLEANER FOR SHOP & TRUCKS

HANDCARE CLEANER is specifically formulated to gently remove a variety of soils and effectively cleanse hands. Hand cleaner is dermatologist-tested.

PART#	DESCRIPTION
G0955	½ gal. Orange Pumice Hand Cleaner with Pump Dispenser Medium Soils Disposable



G0955

HEADLIGHTS

LED HEADLIGHT

Energizer's Vision LED HEADLIGHT offers hands-free operation with two light modes that control brightness and runtime, making it up to four-times brighter than standard LEDs. It comes with a pivoting head, slide switch, and three AAA batteries. Impact resistant to 1 m. 1 1/2". Blue. 100 Lumens; 7 hr Runtime, 30m Beam Distance.

PART#	DESCRIPTION
HDA32E	LED Headlight, Blue
ALK92	AAA Alkaline Battery



HDA32E

From **Streamlight®**, the **trident®** and **enduro® LED HEADLAMPS** provide superior lighting, while leaving your hands free. The **Trident Headlamp** features a super-bright xenon bulb with triple LEDs, 90° tilting head, and three-way lighting for short, medium, and long distances (with spot to-flood adjustment). The lightweight **Enduro Headlamp** features high and low lighting modes, a .5 watt high-flux LED, and o-ring sealed construction. Both headlamps are water resistant with scratch-resistant polycarbonate bodies and come with an adjustable elastic/rubber combo head strap for maximum stability.

PART#	DESCRIPTION
SL61049	Trident Xenon/LED Headlamp, Orange/Black/Yellow
SL61410	Enduro LED Headlamp, Black/Gray
ALK92	AAA Alkaline Battery



SL61049



SL61400

- **FIRE EXTINGUISHER PARTS**



GAUGES

DRY CHEMICAL GAUGES

Listed by Underwriters Laboratories.

PART#	DESCRIPTION
G100	100 lb Dry Chemical Gauge
G125	125 lb Dry Chemical Gauge
G150	150 lb Dry Chemical Gauge
G175	175 lb Dry Chemical Gauge
G195	195 lb Dry Chemical Gauge
G235	235 lb Dry Chemical Gauge
G240	240 lb Dry Chemical Gauge
G350	350 lb Dry Chemical Gauge
G360	360 lb Dry Chemical Gauge
AS56776	195 lb Ansul Dry Chemical Gauge
K293789	100 lb Kidde Dry Chemical Gauge
K293266	195 lb Kidde Dry Chemical Gauge
K259535	Kidde Gauge O-Ring (For Plastic Valve)



PRESSURIZED WATER, FOAM, LOADED STREAM GAUGES

Listed by Underwriters Laboratories.

PART#	DESCRIPTION
OFG100	100 lb Water, Foam, Mist, Loaded Stream Gauge (Oil Filled Gauge)
OFG100P	100 lb Water, Foam and Loaded Stream Gauge c/w O-ring
OR009	O-Ring, Pyrene Type
G100K	100 lb Wet Chemical Gauge



CLEAN AGENT GAUGES

Listed by Underwriters Laboratories.

PART#	DESCRIPTION
HG100	Gauge - 100 PSI (Halon)
G195H	Gauge - 195 PSI (Halon)
G100T	Gauge - 100 PSI (Halotron I)
G125T	Gauge - 125 PSI (Halotron I)
AS426264	125 lb Ansul Cleanguard (FE36) Gauge
AS428940	75 lb Ansul Cleanguard (FE36) Gauge



NITROGEN VALVE GAUGES

Listed by Underwriters Laboratories.

PART#	DESCRIPTION
G3000	3000 PSI Gauge for N100 and N200QR Valve
G4000	4000 PSI Gauge for N100-4 and N200QR4 Valve



GAUGE SERVICE EQUIPMENT

The **GAUGE WRENCH** is designed for removing/attaching most gauges and features $\frac{3}{16}$ " cold-rolled plated steel construction.

PART#	DESCRIPTION
GWRENCH	Gauge Wrench



GWRENCH

BUBBLES LEAK DETECTOR adheres to overhead surfaces, leaves no residue, and dries clean and clear. Its patented self-storing "Squirtubes" have small bores for dispensing small quantities, and it is okay to use for CO₂, nitrogen, and halon. 8 oz.

PART#	DESCRIPTION
LD1	8 oz. Squirt'n Bubbles Leak Detector



LD1

VALVE STEMS

DRY CHEMICAL VALVE STEMS

Amerex

PART#	DESCRIPTION
A6092	Amerex Valve Stem Assembly, 2" L
A6093	Amerex Valve Stem Assembly, 2 $\frac{9}{16}$ " L



A6092

A6093

Ansul

PART#	DESCRIPTION
ASVS4	Valve Stem (24489), Ansul Type, 2 $\frac{1}{8}$ " L
ASVS5	Valve Stem (54227), Ansul Type, 1 $\frac{5}{8}$ " L
AS429099	Ansul® Sentry® Valve Stem, 1 $\frac{5}{8}$ " L
AS428431	Ansul® Sentry® Valve Stem, Corrosion Resistant, 1 $\frac{5}{8}$ " L



ASVS4

AS429099

ASVS5

AS428431

Badger

PART#	DESCRIPTION
B23795	Badger Valve Stem Assembly, 2 $\frac{3}{8}$ " L
B19010	Badger Valve Stem Assembly, 1 $\frac{3}{4}$ " L
B23389	Badger Valve Stem Assembly, 1 $\frac{3}{4}$ " L
P440068K	Badger/Kidde Valve Stem Assembly, 1 $\frac{5}{8}$ " L



B23795

B19010

P440068K

Buckeye

PART#	DESCRIPTION
BU103215	Buckeye Valve Stem Assembly, 1 $\frac{3}{4}$ " L
WVS13	Valve Stem (100214), Buckeye Type, 1 $\frac{11}{16}$ " L
WVS15	Valve Stem (106215), Buckeye Type, 2 $\frac{5}{16}$ " L



BU103215

Flag Fire

PART#	DESCRIPTION
FVS1	Valve Stem (11130), Flag Type, 2" L
FVS4	Valve Stem (10990), Flag Type, 2 $\frac{5}{16}$ " L



FVS1



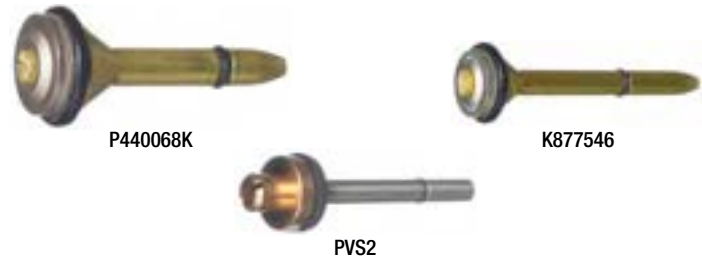
FVS4

CLEAN AGENT VALVE STEMS

Kidde/Pyrene

PART#	DESCRIPTION
P440068K	Badger/Kidde Valve Stem Assembly, 1 $\frac{3}{8}$ " L
K440020	Kidde Valve Stem Assembly, 1 $\frac{3}{8}$ " L
K877546	Kidde Valve Stem Assembly, 2" L
PVS2	Valve Stem (12141), Pyrene Type, 1 $\frac{3}{4}$ " L

Discontinued



PyroChem

PART#	DESCRIPTION
AS429099	Ansul® Sentry® Valve Stem, 1 $\frac{5}{8}$ " L



Strike First

PART#	DESCRIPTION
C161428	Strike First Valve Stem Assembly, 2 $\frac{1}{8}$ " L
C110427	Strike First Valve Stem Assembly, 1 $\frac{7}{8}$ " L



PRESSURIZED WATER, FOAM, WATER MIST, LOADED STREAM VALVE STEMS

Amerex

PART#	DESCRIPTION
A6093	Amerex Valve Stem Assembly, 2 $\frac{3}{16}$ " L
A14878	Amerex Valve Stem Assembly, 2 $\frac{3}{16}$ " L



Ansul

PART#	DESCRIPTION
AS429099	Ansul® Sentry® Valve Stem



Badger

PART#	DESCRIPTION
B23795	Badger Valve Stem Assembly, 2 $\frac{3}{8}$ " L



Buckeye

PART#	DESCRIPTION
BU900921	Buckeye Valve Stem Assembly, 2 $\frac{5}{8}$ " L



Flag Fire

PART#	DESCRIPTION
AS429099	Ansul® Sentry® Valve Stem, 1 $\frac{5}{8}$ " L
FVS4	Valve Stem (10990), Flag Type, 2 $\frac{5}{16}$ " L



Strike First

PART#	DESCRIPTION
C161628	Strike First Valve Stem Assembly, 2 $\frac{1}{8}$ " L



CO2 VALVE STEMS

Amerex

PART#	DESCRIPTION
A1539	Amerex Valve Stem Assembly, 2¾" L



A1539

Ansul

PART#	DESCRIPTION
AS441004	Ansul® Sentry® Valve Stem
RS0108	Valve Stem Assembly (79806), 2¼" L



AS441004



RS0108

Badger

PART#	DESCRIPTION
B20981	Badger Valve Stem Assembly, 2⅝" L
RS0108	Valve Stem Assembly (79806), 2¼" L



B20981



RS0108

Buckeye

PART#	DESCRIPTION
BU900321	Buckeye Valve Stem Assembly, 2¼" L



BU900321

Strike First

PART#	DESCRIPTION
SF31132	Strike First Valve Stem Assembly (Pre '05), 2" L
SF31133	Strike First Valve Stem Assembly (Present)



SF31132

Flag Fire

PART#	DESCRIPTION
FVS10	Valve Stem (11720), Flag Type, 2¼" L



FVS10

R.S. PSH Model

Diamond, Ansul, R.S. Models with RS Valve.

PART#	DESCRIPTION
RS0108	Valve Stem Assembly (79806), 2¼" L



RS0108

CLEAN AGENT VALVE STEMS

Amerex

PART#	DESCRIPTION
A14327	Amerex Valve Stem Assembly (green seal)
A6092	Amerex Valve Stem Assembly, 2" L
A6093	Amerex Valve Stem Assembly, 2⅞" L
A13288	Amerex Valve Stem Assembly (green seal)



A6092



A6093



ASVS4



AS429099

Ansul

PART#	DESCRIPTION
ASVS4	Valve Stem (24489), Ansul Type, 2⅞" L
AS429099	Ansul® Sentry® Valve Stem, 1⅝" L
AS428431	Ansul® Sentry® Valve Stem, Corrosion Resistant, 1⅝" L



AS428431

We are in the business of growing your business

CLEAN AGENT VALVE STEMS CONTINUED

Badger

PART#	DESCRIPTION
B18672	Badger Valve Stem Assembly
B23086	Badger Valve Stem Assembly, 2½"

Buckeye

PART#	DESCRIPTION
BU103214	Buckeye Valve Stem Assembly, 1½" L
BU103216	Buckeye Valve Stem Assembly



BU103214

Kidde / Pyrene

PART#	DESCRIPTION
K440007	Kidde Valve Stem Assembly

O-RINGS, GASKETS AND QUAD RINGS

COMPONENT O-RINGS

PART#	DESCRIPTION
OR006	Shaft O-Ring - Amerex (5235)
OR010	Shaft O-Ring - Pyrene (12468), General (2520)
OR012	Shaft O-Ring - Flag (10192)
OR110	Shaft O-Ring - Diamond (161851)
OR201	Shaft O-Ring - General (33030)



ORINGS

PART#	DESCRIPTION
OR8	Amerex (1532), Badger (14911), General (5857)
OR10	Amerex (6978), Kidde (643580012)
OR18	Ansul (Nozzle Tip 3469), Badger (701), General (33449, 21574), Kidde (56610011)
OR117	Buckeye (900004), Flag (10418), General (11178)



ORINGS

PART#	DESCRIPTION
OR212	Amerex (5241), Badger (16370, 20745), Flag (10513), Kidde (320680)
OR215	Amerex (5240), Badger (20746), Pyrene (12667), Diamond (16135)
OR218	Kidde (64350218, 68260218)



ORINGS

PART#	DESCRIPTION
OR223	General (32518)
OR221	General (33806)
OR912	Kidde (320005)
OR216A	Amerex (1124), Badger (16464), Buckeye (900329), RS Flag (10635)
OR115	Pyrene (12301, 12848)
OR122	Pyrene (12155)
OR118	Diamond (161345), General (33178)
OR120	Flag (10447), Pyrene (12154)



ORINGS

COMPONENT O-RINGS CONTINUED

PART#	DESCRIPTION
OR111	Amerex (5689), RS87 Stem Seal
AN6324*	Ansul (6324)

*Sold individually

PART#	DESCRIPTION
AN6323*	Ansul Hose Assembly O-Ring 20E8G

*Sold individually



ORINGS

GASKETS AND QUAD RINGS

PART#	DESCRIPTION
AN615	Ansul Type 5lb. Fill Cap Gasket
G45	Ansul (181) Gasket Actuator
G48	Ansul (6190) Gasket Fill Cap 10/20/30 A101 Tank
G50W	Ansul Fill Cap Gasket, Wheeled Unit
QR39	Ansul (6273) Quad Ring 10/20/30 E/G
QR40	Collar Quad Ring 16222 Ansul Type
QR41	Ansul (79122)
QR43	Ansul (21882)
OR232	General (23506)



GASKET & QUAD RINGS

SEE MANUFACTURERS PICTOGRAMS FOR O-RINGS NOT SHOWN

O-RING KIT contains 20 each of our 18 best sellers for a total of 360 o-rings and quad ring seals. Comes in a handy storage box with full scale illustration of each one.

PART#	DESCRIPTION
OKIT	O-Ring Kit

OKIT



O'RING LUBRICANT

Visilox silicone Grease is excellent for halon o-rings.

PART#	DESCRIPTION
SLUBE	Stiff, Tacky, Dielectric Silicone Grease, 5oz

SLUBE



OLUBE884-2

PARKER O-LUBE is an outstanding general purpose grease for o-ring and seals. Excellent for dry chemical o-rings to protect from abrasion.

PART#	DESCRIPTION
OLUBE884-2	O-Ring Lubricant, 2oz

RIVETS

RIVET KIT contains 20 each of our 18 best sellers for a total of 360 rivets. Handy storage box includes full scale illustrations.

PART#	DESCRIPTION
RKIT	Rivet Kit



RKIT

RIVETS

PART#	DESCRIPTION
RV5	Amerex Handle (1564, 1064)
A1563	Amerex Handle (1563, 1060)
RV14	General Lever (13145, 32057)
RV30	Badger Handle (6561, 16517, 4095)
RV38	Buckeye Handle/Lever (900042)
RV44	Ansul Handle (25719)
RV46	General Handle (32075) AS STOCK ALLOWS
RV47	Ansul Handle (25720)
RV48	General Lever (32061) AS STOCK ALLOWS
RV49	General Handle (32058)
RV53	General Handle/ Lever (33699)
RV85	Flag Lever/Handle (Old Style) (10296)
RV87	Pyrene Lever (12158, 13526)
RV89	Pyrene Lever (12664)
RV63	General Handle (34076) (RS0103), Ansul (418689)
RV64	General Handle (35774) AS STOCK ALLOWS
RV67	General Handle (32062)
RV71	General Lever (34991, 35773)
RV78	Ansul Lever/Handle (17050)
RV80	Diamond & Strike First Lever/Handle (162803)
RV81	Kidde Handle (206363), Fyr-Fyter (50013) RS0105, Ansul (418690)
RV68	General Handle (33250)
RV91	Ansul Carry Handle (1265)
RV93	General Lever (32123)
RV94	General Handle (34992)

RIVETS



Discontinued

SEE MANUFACTURERS PICTOGRAMS FOR RIVETS NOT SHOWN

TAMPER SEALS

DATED TAMPER SEALS

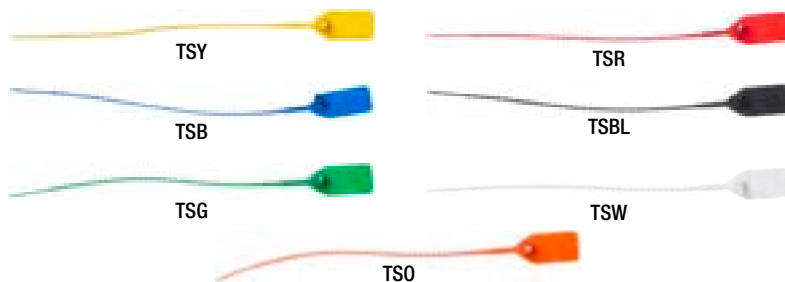
FLAME® DATED TAMPER SEALS are a UL recognized components for fire extinguishers and available in many color combinations. Dated with the current year (shows seal has been replaced during annual maintenance, according to NFPA 10). Measures 9" long. Sold in bags of 500 (50 matted sheets of 10 each). Seals break under 15 ft lbs per UL guidelines. **Ordering information: Replace the XX with the two-digit year code.**

PART#	DESCRIPTION
FLMRW-XX	Flame® Dated Tamper Seal, Red w/ White Imprint
FLMYBK-XX	Flame® Dated Tamper Seal, Yellow w/ Black Imprint
FLMBW-XX	Flame® Dated Tamper Seal, Blue w/ White Imprint
FLMBKGD-XX	Flame® Dated Tamper Seal, Black w/ Gold Imprint
FLMWB-XX	Flame® Dated Tamper Seal, White w/ Blue Imprint
FLMGW-XX	Flame® Dated Tamper Seal, Green w/ White Imprint
FLMWR-XX	Flame® Dated Tamper Seal, White w/ Red Imprint



DATED MEDIUM TAMPER SEALS are a UL recognized components for fire extinguishers. Available in seven colors, they come dated (current year) to show seals have been replaced during annual maintenance (in accordance with NFPA 10). Measures 9". Bag/500. Seals break under 15-ft lbs per UL guidelines. **Ordering information: Replace the XX with the two-digit year code.**

PART#	DESCRIPTION
TSY-XX	Medium Date Tamper Seal, Yellow
TSR-XX	Medium Date Tamper Seal, Red
TSB-XX	Medium Date Tamper Seal, Blue
TSBL-XX	Medium Date Tamper Seal, Black
TSG-XX	Medium Date Tamper Seal, Green
TSW-XX	Medium Date Tamper Seal, White
TSO-XX	Medium Date Tamper Seal, Orange

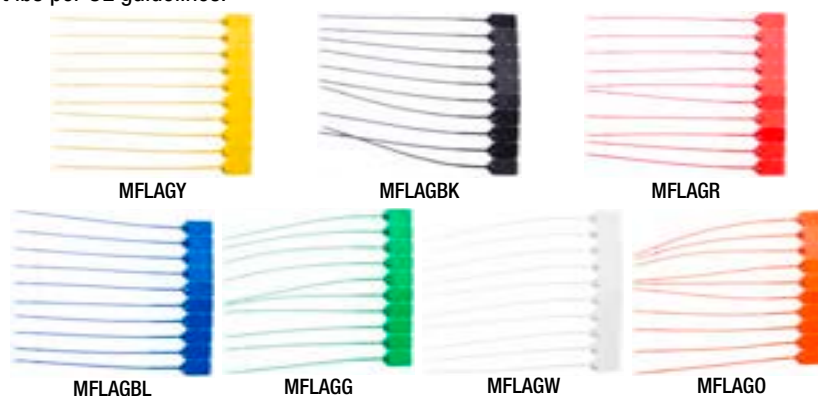


CUSTOM TAMPER SEALS available with your Company Name/Logo. Minimum of 10,000 seals. These seals are a UL recognized components for fire extinguishers. Available in seven colors, they come dated (current year). Measures 9". Bag/500. Seals break under 15-ft lbs per UL guidelines.

DATELESS TAMPER SEALS

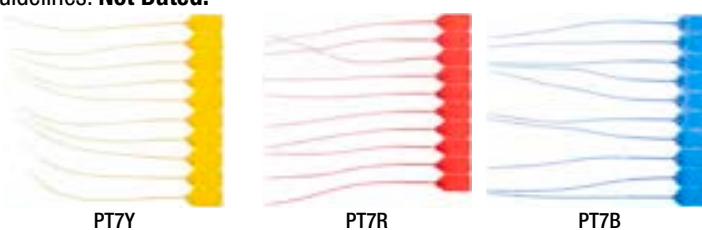
DATELESS MEDIUM-MATTED TAMPER SEALS are UL recognized components for fire extinguishers. Available in seven colors. Measures 9". Sold in bags of 500 (50 matted sheets of 10 each). Seals break under 15-ft lbs per UL guidelines.

PART#	DESCRIPTION
MFLAGY	Medium-Matted Tamper Seal, Yellow
MFLAGBK	Medium-Matted Tamper Seal, Black
MFLAGR	Medium-Matted Tamper Seal, Red
MFLAGBL	Medium-Matted Tamper Seal, Blue
MFLAGG	Medium-Matted Tamper Seal, Green
MFLAGW	Medium-Matted Tamper Seal, White
MFLAGO	Medium-Matted Tamper Seal, Orange



BULL'S EYE TAMPER SEAL are a UL recognized component for fire extinguishers. Available in three colours. Sold in bags of 500 (50 matted sheets of 10 each) and measures 9" long. Seals break under 15-ft lbs per UL guidelines. **Not Dated.**

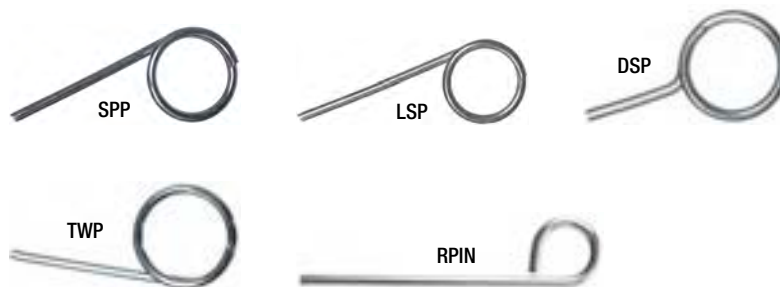
PART#	DESCRIPTION
PT7Y	Bull's Eye Tamper Seal, Yellow
PT7R	Bull's Eye Tamper Seal, Red
PT7B	Bull's Eye Tamper Seal, Blue



PULL PINS

PULL PINS, CHAIN & KEY

PART#	DESCRIPTION
SPP	Single Point Pull Pin (Steel)
DSP	Diamond Single Point Pin (Steel)
LSP	Long Pull Pin, Stainless Steel
TWP	Thin Wire Pull Pin, Steel
RPIN	Hose Rack Pull Pin



PULL PINS, CHAIN & KEY

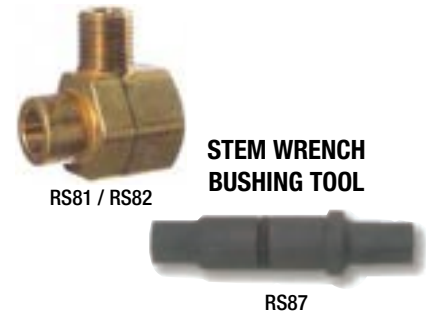
PART#	DESCRIPTION
AN7095	Ansul Pull Pin - 10 & 30 lb. D/C
AN2332	Ansul Pull Pin - 5 lb. Cartridge
SNP	Red Plastic Pull Pin
K259057	Kidde Red Plastic Pull Pin
SF755651	Red Plastic Strike Pull Pin
CHAIN	4" Galvanized Chain
KEY	Cotter Key for Use w/Chain
A532	Nylon Chain for Pull Pin (Amerex)



CARTRIDGE FILLING BONNET, BUSHINGS & SHIPPING CAPS

FILLING BONNET

PART#	DESCRIPTION
RS81LH	Filling Bonnet for Ansul & General D/C CO2 Cartridge Extinguisher
RS82RH	Filling Bonnet for use with Ansul Systems Cartridge
OR211	O-Rings for Bonnets
RS87	Bushing Tool for use with Bonnets
OR111	O-Ring for RS87 Stem (Package of 10)



"A" BUSHING and **"AA" BUSHING** should be tightened to 40 ft.-lbs. torque at room temperature.

PART#	DESCRIPTION
A	Bushing for Cartridge Type Portable D/C Extinguisher Cartridges CO2
AA	Bushing for Cartridge Type D/C Systems & Nitrogen Cartridges



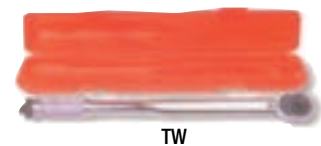
"E" BUSHING should be tightened to 25 ft.-lbs. torque at room temperature.

PART#	DESCRIPTION
E	Bushing for General Outside Mounted D/C Extinguisher Cartridges



TORQUE WRENCH (1/2" - 150 ft. lbs.) with dial in torque setting. Wrench indicates desired torque by feel and sound.

PART#	DESCRIPTION
TW	Reversible Ratchet Torque Wrench



ANSUL CARTRIDGE SHIPPING CAPS

The above parts and accessories are only a partial list of item and equipment needed to safely refill carbon dioxide and nitrogen cartridges. These parts and accessories should be purchased and used only by personnel who are thoroughly familiar with and understand the standards published in the Compressed Gas Association pamphlets G-6 and S-1.1, code of federal regulations title 49, parts 100 thru 199 and who have received "hands-on" training under the direct supervision of someone experienced in cartridge refilling. If you lack the knowledge, training or experiences described above, do not attempt to refill either carbon dioxide or nitrogen cartridges. Instead, we recommend that you purchase either new cartridges or those refilled by an established service facility. **Failure to adhere to the above instructions could result in death or serious injury!**

PART#	DESCRIPTION
LHSC	Ansul LH Cartridge Shipping Cap
RHSC	Ansul RH Cartridge Shipping Cap



CARTRIDGE CAP WRENCH for removing caps from cartridge operated extinguishers.

PART#	DESCRIPTION
CCW1	Cap Wrench for most Cartridge Units



CCW1

SYPHON TUBES

SYPHON TUBES for extinguisher and commercial **CO2 VALVES**. **Note:** always make sure that syphon tube is proper length! When valve is installed, bottom of syphon tube should clear bottom of cylinder by about 1/4". After measuring, if cutting is required, a 45° cut is extra insurance against tube sealing on bottom of cylinder.

PART#	DESCRIPTION
5SYP	2½ and 5 lbs. CO2 Syphon Tube
10SYP	10 lbs. CO2 Syphon Tube
15SYP	15 and 20 lbs. CO2 Syphon Tube
50SYP	50 and 75 lbs. CO2 Syphon Tube, Fits RS50
50BIST	Black Iron Syphon Tube, 53½" x ¼", NPT, Fits CM7, CM10

For Sherwood Commercial Valve use Adapter Comb



5SYP / 10SYP / 15SYP / 50SYP

CO2 & NITROGEN VALVES

CO2 EXTINGUISHER VALVE FOR STEEL CYLINDER

PART#	DESCRIPTION
PSH2	CO2 Valve for 2½ lb. and 5 lbs. ½" Neck Steel Cylinders
RS0108	Valve Stem Assembly (79806), 2¼" L
SW50	Swivel Discharge Assembly for PSH2 Valve & PSH5AL
RS5	Ansul & RS CO2 Disc, Washer & Nut Assembly, Torque 40 ft-lb



PSH2



SW50

PART#	DESCRIPTION
PSH1	CO2 Valve with Latch for 1" Neck Steel Cylinders
RS0108	Valve Stem Assembly (79806), 2¼" L
ELB25	¼" Elbow with Diffuser for PSH1
ELB37	¾" Elbow with Diffuser for PSH1
RS5	Ansul & RS CO2 Disc, Washer & Nut Assembly, Torque 40 ft-lb



PSH1



ELB25



ELB37

CO2 EXTINGUISHER VALVE FOR ALUMINUM CYLINDER

PART#	DESCRIPTION
PSH10AL	CO2 Valve for 1¾" Neck Aluminum Cylinders, 10-15-20 lbs. CO2
SWT2	½" Brass Discharge Tube for 5 lbs. CO2
RS5	Ansul & RS CO2 Disc, Washer & Nut Assembly, Torque 40 ft-lb



PSH10AL



SWT2

We are in the business of growing your business

WHEELED UNIT VALVES FOR DRY CHEMICAL AND CO2 UNITS

WHEELED UNIT VALVE for 50-100 lb CO2 units

PART#	DESCRIPTION
RS50	1" Handwheel Valve for 50-100 lbs. CO2 Cylinders
RS50SD	Safety Disc and Washer, RS50 valve
50SYP	50 and 75 lbs. CO2 Syphon Tube, Fits RS50
G12809*	Valve Stem for RS50 (Not Shown)
CWV	End of Line Valve Assembly for 50 and 75 lb. CO2, 1/2" M x 3/8" F

*Not Shown



WHEELED UNIT VALVES for Dry Chemical Wheeled Units

PART#	DESCRIPTION
N100	3/4" Nitrogen Valve with 3000 PSI Gauge
N100-4	3/4" Nitrogen Valve with 4000 PSI Gauge
N200QR	3/4" Quick Release Nitrogen Valve with 3000 PSI Gauge
N200QR4	3/4" Quick Release Nitrogen Valve with 4000 PSI Gauge
NEW RS1070*	Safety Disc (3360 PSI), Washer and Nut Assembly, N100/ N200QR (one piece complete)
NSD	Safety Disc (3360 PSI) and Washer for N100 & N200QR
QR4SD	Safety Disc (4000 PSI) and Washer for N200QR4, N100-4
N1060	Safety Nut Only, N100 & N200QR (stamped 3360 PSI)
NEW N1060QR	Safety Nut Only, N100-4, N200QR4 (stamped 4000 PSI)
G3000	3000 PSI Replacement Gauge for N100 & N200QR
G4000	4000 PSI Replacement Gauge for N200QR4, N100-4
N1050	Valve Stem for N100, N100-4
NITA	Recharge Adapter N100 - N200

*Not Shown



BRASS COMMERCIAL CO2 VALVES

SHERWOOD BRASS COMMERCIAL CO2 VALVES FOR ALUMINUM AND STEEL CYLINDERS. These valves come threaded to accept syphon tube (except CM5) when COMB adapter is used.

PART#	DESCRIPTION
CM5	CO2 Valve for 1/2" Neck Steel Cylinders
CM7	CO2 Valve for 3/4" Neck Steel Cylinders
CM10	CO2 Valve for 1" Neck Steel Cylinders
CMA10	CO2 Valve for 1 1/8" Straight Thread Aluminum Cylinders complete with OR216A
COMB	Syphon Tube Adapter for Commercial Valves, Fits only 5SYP, 10SYP, 15SYP
5SYP	2 1/2 and 5 lbs. CO2 Syphon Tube
10SYP	10 lbs. CO2 Syphon Tube
15SYP	15 and 20 lbs. CO2 Syphon Tube
50BIST	Black Iron Syphon Tube, 53 1/2" x 1/4", NPT, Fits CM7, CM10



BRASS COMMERCIAL NITROGEN VALVES

COMMERCIAL NITROGEN VALVES

PART#	DESCRIPTION
NIT75	3/4" Nitrogen Valve with CGA 580 Outlet
NIT100	1" Nitrogen Valve with CGA 580 Outlet
PC1	Plastic Thread Protector for 1/2" Outlet Valves
PC2	SCBA Thread Saver for Scott, MSA and Survivair w/18" Cord
158	Hand Wheel Grip for Valves



NIT75 / NIT100



PC1



PC2
SCBA THREAD
SAVER FOR
SCOTT & MSA



158

CO2 SAFETY DISCS & WASHERS

CO2 SAFETY DISCS & WASHERS. Call Technical Support for torque information.

PART#	DESCRIPTION
A4000	Amerex Disc, Washer & Nut Assembly 250 in-lb (21 ft-lb) (Also 3090A, 9895A Valves)
F429515	Ansul Disc, Washer & Nut Assembly 35 ft-lb
RS5	Ansul & RS CO2 Disc, Washer & Nut Assembly, Torque 40 ft-lb
B24643	Badger Disc, Washer & Nut Assembly 25 - 30 ft-lb
BU200081	Buckeye Disc, Washer & Nut Assembly 32 ft-lb
F10066	Flag Type Disc & Washer - Older Models (As Stock Allows)
F429515	Flag Disc, Washer & Nut Assembly - New Model 35 ft-lb
RSSW	Plastic Washer
B24643	Kidde Disc, Washer & Nut Assembly 25 - 30 ft-lb Torque
K260299	Kidde Safety Disc (Aluminum Valves) 250 - 275 in-lb (21-23 ft-lb)
K258443	Kidde Aluminum Washer
RS5	Ansul & RS CO2 Disc, Washer & Nut Assembly, Torque 40 ft-lb
P10416	Pyrene/Chubb Safety Disc & Washer 40 ft-lb
RS50SD	Safety Disc-Washer 35-40 ft-lb
G1707	Safety Disc 35-40 ft-lb (RS50)
SF31145	Safety Cap Assembly (Strike First)



CO₂ SAFETY DISC & WASHERS
& COMPLETE ASSEMBLIES

CO2 HORNS, NIPPLES & HANDLES

WHEELED CO2 HORN ASSEMBLY

NOTE: The nipple/handle attaches to the female side of the valve assembly. The horn attaches to the other end of the nipple. The hose attaches to the male side of the valve.

PART#	DESCRIPTION
CWV	Valve Assembly for 50 and 75 lbs. CO ₂ , 1/2" M x 3/8" F
CWH	CO ₂ Horn with Diffuser for CWV Valve
CWN	Galvanized Steel Nipple 3/8" x 18"
CWR	Rubber Handle for CWN Nipple



HAND HELD CO2 EXTINGUISHER HORNS & ACCESSORIES

Note: There are several different designs of 5 lbs. CO2 horns and discharge tubes. Carefully check the horn and tube to order the correct replacement parts. Also, some discharge tubes have a long diffuser tip and will not work with some horns. Test for flow of CO2 through the discharge tube and horn assembly to be sure.

PART#	DESCRIPTION
CH5	5 lbs CO2 Horn with Diffuser (for use with discharge tubes with no diffuser)
CH5D	5 lbs CO2 Horn (for use with discharge tubes with a built in diffuser)
CH10	Conical Horn with Brass Diffuser (for 10 lbs CO2 Extinguishers)
CH15	Conical Horn with Brass Diffuser (for 15 and 20 lbs CO2 Extinguishers)
RDH10	Rapid Discharge Horn & Handle for 10 lbs CO2 Extinguishers)
RDH15	Rapid Discharge Horn & Handle for 15 and 20 lbs CO2 Extinguishers)
F429184	FLAG 5 lbs CO2 Horn (10204)
AN429197	10 - 15 - 20, 50 lbs CO2 Horn (F1072)
RDC	Diffuser Clip for RDH CO2 Horn
RDD	Diffuser for RDH CO2 Horn
RH6	Rubber Handle for all Conical Horns
ESN7	¼" Diameter x 6" Long Galvanized Steel Nipple
HHANDLE	Rubber Handle for General Horns
HNIPPLE	¼" Diameter x 8" Long Galvanized Steel Nipple for use with HHANDLE AS STOCK ALLOWS



DISCONTINUED

REPLACEMENT BANDS AND STRAPS

SAFETY HORN HOLDER keeps the horn in the down position against the extinguisher, preventing water from entering hose/horn. Use UHS34 strap to install (sold separately).

PART#	DESCRIPTION
SHH	Safety CO2 Horn Holder
UHS34	Universal Hose Strap (black) (34" Long)



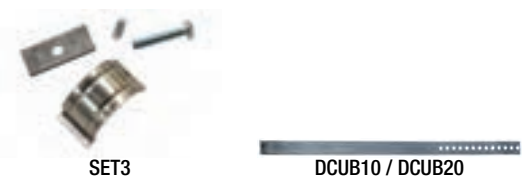
HOSE HOLDER FOR DRY CHEMICAL & PRESSURE WATER

PART#	DESCRIPTION
A14776	Strap and Clip, 24" Long x ¾" Wide (black)
A14778	Strap and Clip for 7" Diameter Extinguishers 24" Long x ½" Wide (black)



DRY CHEMICAL REPLACEMENT BANDS for 10-20 lbs. cylinders.

PART#	DESCRIPTION
DCUB10	Aluminum 10 lb. Dry Chemical Band
DCUB20	Aluminum 20 lb. Dry Chemical Band
SET3	Hardware for ABCB and DCUB Dry Chemical Bands. Includes Bar/ Nut/ Screw/ Clip.



MAGNETIC HOSE RETAINER is designed specifically for 3/8" diameter hoses. The hose and nozzle assembly, with magnetic retainer, is easily pulled free from the shell when in use and simply reattached to the shell after discharge. Note the word "UP" faces toward the top of the extinguisher. For all 3/8" diameter hose. Fits Ansul Sentry Dry Chemical Models 5 and 10 and Cleanguard Model FE05 extinguishers.

PART#	DESCRIPTION
AN447635	Magnetic Hose Retainer



AN447635

CO2 REPLACEMENT BANDS for 10-20 lbs. cylinders.

PART#	DESCRIPTION
AUBC	Aluminum 10-20 lbs. Conical Discharge Horn Band
SET1	Hardware for AUBC Band (Bar/Nut/Screw)
ARD	Aluminum 10 - 20 lbs. Rapid Discharge Horn Band
SET2	Hardware for ARD Band (Spacer/Nut/Screw & Washer)



SET2



AUBC WITH PICTO-GRAM (BILINGUAL)
CONICAL DISCHARGE HORN BAND



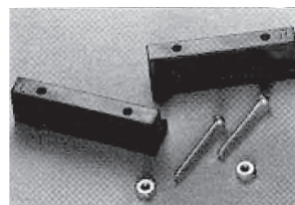
SET1



ARD WITH PICTO-GRAM (BILINGUAL)
RAPID DISCHARGE HORN BAND

CO2 REPLACEMENT BANDS for 10-20 lbs. cylinders.
FLAG TYPE

PART#	DESCRIPTION
RS10	Replacement Band for Flag 10 lb CO2 (1415)
RS15	Replacement Band for Flag 15 lb CO2 (1416)
RS20	Replacement Band for Flag 20 lb CO2 (1417)
FSET	Hardware for Flag CO2 Bands



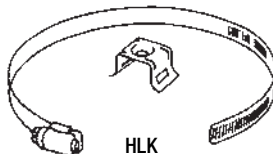
FSET



RS10, RS15, RS20 WITH PICTO-GRAM
(BILINGUAL)

UNIVERSAL REPLACEMENT BRACKET

PART#	DESCRIPTION
HLK	Replace Broken Hanger Loops (Fits up to 8 1/2" Diameter Cylinders)



HLK

REPLACEMENT BANDS abc dry chemical replacement bands.

PART#	DESCRIPTION
ABCB10	Replacement 10 lb ABC Dry Chemical Band
ABCB20	Replacement 20 lb ABC Dry Chemical Band
SET3	Hardware for ABCB and DCUB Dry Chemical Bands. Includes Bar/ Nut/ Screw/ Clip.



ABCB10 / ABCB20



SET3

UNIVERSAL HOSE STRAP AND CLIP

PART#	DESCRIPTION
UHC	Universal Hose Clip
UHS34	Universal Hose Strap (black) (34" Long)



UHC W/ UHS34



UHS34



UHC

CO2 HOSE ASSEMBLIES

CO2 FIRE EXTINGUISHER HOSE ASSEMBLIES meet or exceed U.L. Standard 154. Perforated rubber covered, wire braided hose with heavy duty brass couplings. Rated at 10,000 lbs. bursting pressure and 2,500 lbs. working pressure.

PART#	DESCRIPTION
361	36" Hose for 10-15-20 lbs Portable CO2 Extinguisher (1/4" F x 1/4" F)
362	36" Hose for 10-15-20 lbs Portable CO2 Extinguisher (1/4" F x 3/8" F)
363	36" Hose for 10-15-20 lbs Portable CO2 Extinguisher (3/8" F x 3/8" F)



36-1 / 36-2 / 36-3

CO2 WHEELED UNIT HOSE assemblies measuring 1/2" meet or exceed U.L. Standard 154. Perforated rubber covered, wire braided hose with heavy duty brass couplings. Rated at 10,000 lbs. bursting pressure and 2,500 lbs. working pressure.

PART#	DESCRIPTION
15FF	15 ft. CO2 Wheeled Unit Hose, 1/2" F x 1/2" F
15FM	15 ft. CO2 Wheeled Unit Hose, 1/2" F x 1/2" M
25FF	25 ft. CO2 Wheeled Unit Hose, 1/2" F x 1/2" F
25FM	25 ft. CO2 Wheeled Unit Hose, 1/2" F x 1/2" M
50FF	50 ft. CO2 Wheeled Unit Hose, 1/2" F x 1/2" F
50FM	50 ft. CO2 Wheeled Unit Hose, 1/2" F x 1/2" M
CPLF	Coupling to change Hose End from 1/2" Male to 1/2" Female
CPLM	Coupling to change Hose End from 1/2" Female to 1/2" Male



CAUTION: RELEASE PRESSURE IN HOSE LINE AFTER USE TO PREVENT BLISTERING

DRY CHEMICAL WHEELED UNIT HOSE

PART#	DESCRIPTION
CEH75	50 ft. of 3/4" D/C Engine Hose (M x F)
CEHG	Gasket for CEH75 Hose



BEVERAGE CYLINDER EQUIPMENT

CARRYING HANDLES & ADAPTERS reduce valve damage & make transporting cylinders easier. They provide protection for almost all CO2 cylinders. The adapter fits steel cylinders with a neck dia. of 1 5/8" to 1 7/8".

PART#	DESCRIPTION
CCH1	Luxfer Carry Handle w/Ring (2 5/8" Neck)
CCH2	Kidde Carry Handle w/Ring (2 3/16" Neck)
CCH3	Catalina Carry Handle w/Ring (2 5/8" Neck)
RING1	CCH1 Replacement Snap Ring
RING2	CCH2 Replacement Snap Ring
RING3	CCH3 Replacement Snap Ring
LHA	CCH1 Carry Handle Adapter



BEVERAGE REGULATORS are for CO2 beverage cylinders only, not to be used on vacuum filling systems for extinguishers.

PART#	DESCRIPTION
BEV5	2000/60 PSI CO2 Beverage Regulator
60G	60 PSI Replacement Gauge for BEV5
2000G	0-2000 PSI Replacement Gauge



VEHICLE BRACKETS

HEAVY DUTY VEHICLE BRACKETS

HEAVY DUTY VEHICLE BRACKETS. Powder coated and proven MIG welded steel construction with catch pin to keep bracket from vibrating open. Pin must be pulled prior to extinguisher removal. VB9 is for large diameter cylinders up to 8" Bracket is 17½" Tall 8¼" Wide & 8" deep with an extra brace to support tall cylinders plus heavier ½" adjustment rod. **Now with Stainless Steel locking pin.**

PART#	DESCRIPTION
VB4	Running Board Bracket for 4" - 4½" Diameter Shells
VB5	Running Board Bracket for 4¾" - 5¼" Diameter Shells
VB6	Running Board Bracket for 5½" - 6" Diameter Shells
VB7	Running Board Bracket for 6¼" - 6¾" Diameter Shells
VB8	Running Board Bracket for 6¾" - 7¼" Diameter Shells
VB9	Running Board Bracket for up to 8" Diameter Shells
VB9BUC	Running Board Bracket for 7¾" - 8" Diameter Shells (Buckeye)
NEW VPINSS	Stainless Steel "Hair Pin" Clip for Heavy Duty Brackets. (Package of 5)
RBP	Rubber Bumper Pad - Fits all Brackets (Not Shown)
VBT	Black Rubber Tether for pull-pin, VB and AG Brackets



BOXED ONE PER CARTON



NEW

VPINSS Package of 5



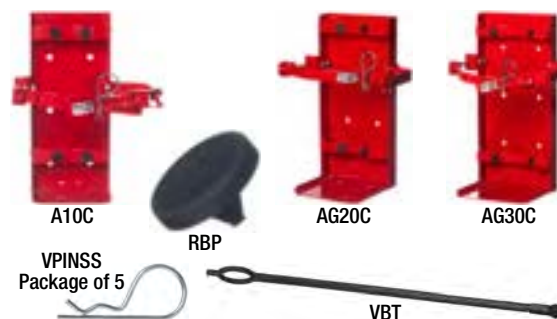
VBT

CARTRIDGE OPERATED VEHICLE BRACKETS

HEAVY DUTY CARTRIDGE OPERATED VEHICLE BRACKETS. Ansul and General. Steel bolted construction design. Latch will not vibrate open. Pin must be pulled prior to extinguisher removal.

POWDER COATED

PART#	DESCRIPTION
A10C	Ansul 10 lbs. Style Cartridge Operated Bracket
AG20C	Ansul and General 20 lbs. Style Cartridge Operated Bracket
AG30C	Ansul and General 30 lbs. Style Cartridge Operated Bracket
VPINSS	"Hair Pin" Clip for Heavy Duty Brackets. (Package of 5)
RBP	Rubber Bumper Pad - Fits all Brackets (Not Shown)
VBT	Black Rubber Tether for pull-pin, VB and AG Brackets



VPINSS Package of 5



VBT

UNIVERSAL BRACKETS

PLASTIC UNIVERSAL SPRING CLIP BRACKETS

PART#	DESCRIPTION
25UPB	Universal Spring Clip Bracket, Plastic Fits 2½ lb. Extinguisher
5UPB	Universal Spring Clip Bracket, Plastic Fits 5 lb. Extinguisher
10UPB	Universal Spring Clip Bracket, Plastic Fits 10 lb. Extinguisher



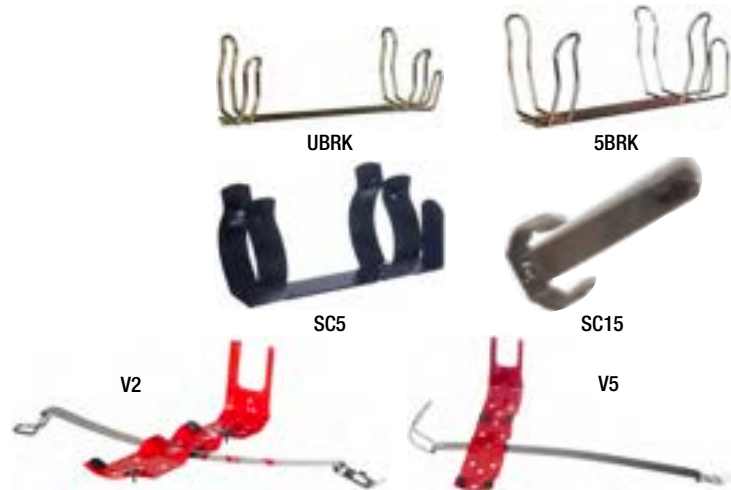
25UPB

10UPB

We are in the business of growing your business

SPRING CLIP BRACKETS. UNIVERSAL

PART#	DESCRIPTION
UBRK	Spring Clip Bracket for 2½ and 2¾ lbs. D/C and Halon Units
5BRK	Spring Clip Bracket for 5 and 6 lbs. D/C and Halon Units
SC5	Spring Clip Bracket for 5 and 6 lbs. D/C, Halon and CO2 Units
SC15	Spring Clip Bracket for 10 and 15 lbs. D/C, Halon and CO2 Units



UNIVERSAL VEHICLE BRACKETS.

PART#	DESCRIPTION
V2	Universal Bracket for 2½ and 2¾ lbs. Units
V5	Universal Bracket for 5 and 6 lbs. Units

PYRENE USE CV110 AND V5P (FOR OLDER CHUBB UNITS)

OEM VEHICLE BRACKETS

VEHICLE BRACKETS. AMEREX

PART#	DESCRIPTION
A818	Vehicle Bracket for Amerex 5 lbs. Units
A817	Vehicle Bracket for Amerex 2½ lbs. Units
A821	Vehicle Bracket for Amerex 5 lbs. Units



VEHICLE BRACKETS. AMEREX

PART#	DESCRIPTION
A846	Vehicle Bracket for Amerex 10 lbs. Units
A860	Amerex Bracket with Cord Fits 3 - 4¼" Diameter Shells
A7166*	Replacement Cord for Brackets A860 and A862

*Not Shown

VEHICLE BRACKETS. AMEREX

PART#	DESCRIPTION
A862	Amerex Bracket with Cord Fits 5 - 7" Diameter Shells
A864	Amerex Bracket with Cord Fits 7 - 8" Diameter Shells
A7802*	Replacement Cord for Bracket A864

*Not Shown

VEHICLE BRACKETS. ANSUL

PART#	DESCRIPTION
AN7077	Vehicle Bracket for Ansul 5 lbs. Cartridge Operated Units
AS24610	Vehicle Bracket for model SY0515 Sentry 2½ and 2¾ lbs. Units
AS54160	Vehicle Bracket for Ansul SY-0515 Models
AS415824*	For Models SY0516, SY0517, SY0521, SY0531 5 lbs. Units
AS429146*	Vehicle Bracket for Ansul A05, AA05, PK05, C05 and FE05

*Not Shown

VEHICLE BRACKETS. KIDDE - PYRENE - BADGER

PART#	DESCRIPTION
K466400	Vehicle Bracket for Kidde 5 and 6 lbs. Units
K466401	Vehicle Bracket for Kidde 2½ and 2¾ Units



Discontinued

EXTINGUISHER WALL HANGERS

WALL HANGERS. AMEREX

PART#	DESCRIPTION
A1521	Amerex Wall Hanger, 5 - 6 lb.
A4834	Amerex Wall Hanger, 1¼ - 2½ lb.
A5525	Amerex Wall Hanger, 6 - 10 lb. (tall)
A9582	Amerex Wall Hanger, 20 lb.
A9581	Amerex Wall Hanger, 30 lb.



ANSUL AND BUCKEYE

PART#	DESCRIPTION
AN2128*	Ansul Wall Hanger, 5 lb.
AN3651	Ansul Wall Hanger, 10 - 30 lb. Cartridge Extinguisher
AS25298	Ansul Wall Hanger, 10 - 14 lb. Sentry
AS30643	Ansul Wall Hanger, 17 - 20 lb. Sentry
AS16819*	Ansul Wall Hanger, 4½ - 9 lb. Sentry



*Not Shown

WALL HANGERS. GENERAL

PART#	DESCRIPTION
G35215	General Wall Hanger, 2½ - 6 lb.
F20	General Wall Hanger, 10 & 20 lb.



WALL HANGERS. KIDDE.

PART#	DESCRIPTION
P320688	Kidde Wall Hanger Pro-Line
K340357*	Kidde Wall Hanger
P340358K*	Kidde Wall Hanger
K340791*	Kidde Wall Hanger



*Not Shown

1" BEAM ADAPTER TO HANG EXTINGUISHER ON I-BEAM

PART#	DESCRIPTION
IBA1	"1" Beam Adapter for Extinguishers Hook
IBA2	Screws to Secure Wall Hook To "1" Beam Clamp, Pkg/100



WALL HANGERS. UNIVERSAL

PART#	DESCRIPTION
WH1	Universal Wall Hanger for 2½ gal. Water
WH5	Universal Wall Hanger for 5 lbs. Extinguisher
WH10	Universal Wall Hanger for 10 - 15 lbs. Extinguisher
WH20	Universal Wall Hanger for 20 lbs. Extinguisher



SEE MANUFACTURERS PICTOGRAMS FOR BRACKETS NOT SHOWN

WALL HANGERS. PYRENE/CHUBB

PART#	DESCRIPTION
P50	(13352) Pyrene Type Wall Hanger, 10 lb.
P60	(13358) Pyrene Type Wall Hanger, 20 lb.
P70	(12676) Pyrene Type Wall Hanger, 10 lb.
P80	(12704) Pyrene Type Wall Hanger, 20 lb.
P90	(12958) Pyrene Type Wall Hanger, 5 lb.



WALL HANGERS. DIAMOND STRIKE FIRST AND FLAG

PART#	DESCRIPTION
C160738	Diamond Wall Brackets, 2½ - 7 lb.
C160752	Diamond Wall Brackets, 10 lb.
C160791	Diamond Wall Brackets, 17 & 20 lb.
C160792	Strike First Wall Brackets, 30 lb.
F10	(10368) Flag Type Wall Hanger, 5 lb. D.C.
F20	(10507) Flag Type Wall Hanger, 5 lb. CO2
F30	(10519) Flag Type Wall Hanger, 10 lb.
F40	(10518) Flag Type Wall Hanger, 15 & 20 lb. and Pressurized Water



● EXTINGUISHER PART PICTOGRAMS

- AMEREX
- ANSUL
- BADGER
- BUCKEYE
- FLAG
- GENERAL
- KIDDE
- PYRENE
- STRIKE FIRST
- PYRO CHEM





**1 - 5 LB. DRY CHEMICAL
(FIXED NOZZLE)
ALUMINUM VALVE MODELS**

A620 - 1 lb. REG	A/B/C403X - 2½ lb. REG	409 - 5 lb. REG
417 - 2½ lb. ABC	410 - 2½ lb. PK	A/B409 - 5 lb. REG
A/B417 - 2½ lb. ABC	A/B410 - 2½ lb. PK	416 - 5 lb. PK
A/B417TX - 2½ lb. ABC	425 - 5 lb. ABC	A/B416 5 lb. PK
403 - 2½ lb. REG		

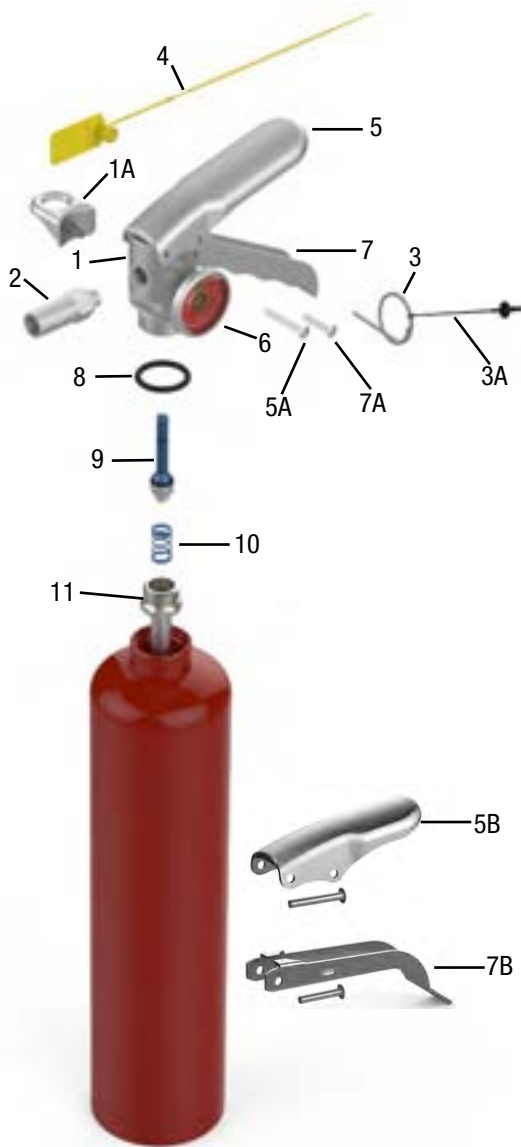


FIG.	PART#	DESCRIPTION	MODEL
1	A12699*	Modified Valve Assembly	Modified Valve
1	A11823*	Standard Valve Assembly	Standard Valve
1A	A14220	Hanger Loop w/Screw	All
2	A12494	Nozzle (.076 SHORT)	A620
2	A1926	Nozzle (.129)	417, A/B417, A/B417TX
2	A3741	Nozzle (.173P)	409, A/B409, 416, A/B416
2	A3211	Nozzle (.120ST)	403, A/B/C 403X
2	A1276	Nozzle (.120)	410, A/B410
2	A1925	Nozzle (.157)	425
3	SPP	Pull Pin	All
3A	A532	Chain (Nylon) for Ring Pin	All
4	TSY	Medium Flag Tamper Seal, Yellow	All
5	A11825	Lever & Rivet	All
5A	A1563	Rivet Only for Lever	All
5B	A2625	Lever & Rivet	Modified Valve
6	G100	Gauge - 100 PSI	A620
6	G195	Gauge - 195 PSI	All but A620
7	A11826	Handle & Rivet	All
7A	RV5	Rivet Only for Handle (OEM# A1064)	All
7B	A9001	Handle & Rivet	Modified Valve
8	OR212	Collar O-Ring, Generic (OEM# A5241)	All
9	A6092	Valve Stem Assembly	All
10	A1074	Spring	All
11	A6069	Downtube/Retainer Assembly	A620
11	A1075	Downtube/Retainer Assembly	417, A417, C403, 403, A403X, B403X, 410, A410
11	A6212	Downtube/Retainer Assembly	409, A/B409, 425, 416, A/B416, B403, B410, B417, A/B417TX

***NOTE 1: All Valve Assemblies include Valve Body, Gauge, Lever and Handle (Loop and Screw on 11823)**

ACCESSORIES

FIG.	PART#	DESCRIPTION	MODEL	NOTES
N/S	RA16	Recharge Adaptor (AD21), 3/8"	All Alum. Valve	
N/S	HTAA3	Hydrotest Adapter - 1"-12 UNF	All Alum. Valve	
N/S	A4834	Wall Hanger Bracket, Red, 1 lb. to 3 lb. Alum Vlv Models	A620, 417, A/B417, A/B417TX, 403, A/B/C403X, 410, A/B410	1 lb. to 3 lb. Models
N/S	A1521	Wall Hanger Bracket, Red, 5 & 5½ lb. Alum Vlv Models	425, 409, A/B409, 416, A/B416	5, 5½ lb. Models
N/S	VB4	Vehicle Bracket for 4 to 4½" Dia. Shells	425, 409, A/B409, 416, A/B416	5lb. Models

**5 - 20 LB. DRY CHEMICAL
(HOSE & HORN)
ALUMINUM VALVE MODELS**



- | | | | |
|---------------------|----------------------|----------------------|---------------------|
| 400 - 5lb. ABC | 453 - 5.5 lb. REG | 443 - 6 lb. ABC | A/B457 - 10 lb. REG |
| A400 - 5 lb. ABC | A/B453 - 5.5 lb. REG | A/B443 - 6 lb. ABC | A411X - 20 lb. ABC |
| A/B402X - 5 lb. ABC | 479 - 5 lb. PK | 456 - 10 lb. ABC | A412 - 20 lb. REG |
| 500 - 5 lb. ABC | A/B479 - 5 lb. PK | A/B456X - 10 lb. ABC | A413 - 20 lb. PK |
| A/B500X - 5 lb. ABC | | | |

FIG.	PART#	DESCRIPTION	MODEL
1	A11823*1	Valve Assembly	5, 5½, 6 & 10 lb.
1	A11824*1	Valve Assembly	20 lb.
1A	A14220	Hanger Loop with Screw	All
2	A7641	Hose & Horn Ass'y (.149)	400, A400
2	A14849	Hose & Horn Ass'y (.157)	A/B402X
2	A6215*2	Hose & Horn Ass'y (.147)	453, A/B453, 500, A/B500X, 500T
2	A5248*2	Hose & Horn Ass'y (.152)	479, 500, 443, A/B479, A/B443, 500T
2	A5564	Hose & Horn Ass'y (.191)	456, A/B456X, A/B457
2	A11221	Hose & Horn Ass'y (.209)	A411X
2	A11223	Hose & Horn Ass'y (.177)	A412, A413
3	OR8	Hose Gasket (O-Ring), Generic (OEM# A1532)	All 5, 6, & 10 lb.
3	OR10	Hose Gasket (O-Ring), Generic (OEM# A6978)	A411X, A412, A413
4	SPP	Ring Pin	All
4A	A532	Chain (Nylon) for Ring Pin	All
5	TSY	Medium Flag Tamper Seal, Yellow	All
6	A11825	Lever & Rivet	All
6A	A1563	Rivet Only for Lever	All
6B	A2625	Lever & Rivet	Modified Valve
7	G195	Gauge - 195 PSI	All
8	A11826	Handle & Rivet	5 to 10 lb.
8	A12405	Handle & Rivet	20 lb.
8A	RV5	Rivet Only for Handle, Generic (OEM# A1064)	All 5 - 10 lb.
8A	A12201	Rivet Only for Handle	20 lb.
8B	A9001	Lever & Rivet	Modified Valve
9	OR212	Collar O-Ring, Generic (OEM# A5241)	All
10	A6092	Valve Stem Assembly	All
11	A1074	Spring	All
12	A6212	Downtube/Retainer Ass'y	A/B402X, 453, 479, 500, A/B453, A/B479, A/B500X
12	A3397	Downtube/Retainer Ass'y	400, 443, A400, A/B443
12	A1519	Downtube/Retainer Ass'y	456, A/B456X, A/B457
12	A11674	Downtube/Retainer Ass'y	A411X, A412, A413



***NOTE 1: All Valve Assemblies include Valve Body, Gauge, Lever and Handle, Loop and Screw**
***NOTE 2: P/N: A5248 & A6215 Hose & Horn Ass'y are both valid for use on Models 500 & 500T**

5 - 20 LB. Dry Chemical (Hose & Horn) Aluminum Valve Model Accessories

FIG.	PART#	DESCRIPTION	MODEL	NOTES
13	A15747	Strap & Clip Ass'y (Black Plastic - 3/8" Hose), All 5-10lb.	All 5, 6 & 10 lb.	
13	A14778	Strap & Clip Ass'y (Black Plastic - 1/2" Hose) All 20lb.	A411X, A412, A413	
14	A12383	Protective Ring for Bottom of 20lb. Cylinder - 7" Diameter	A411X, A412, A413	
N/S	UHS34	Universal Hose Strap, 34", Black		
N/S	UHC	Hose Clip for use with UHS34		
N/S	RA16	Recharge Adaptor (AD21), 3/8"	All EXCEPT 20 lb. Alum. Valve	
N/S	RA11	Recharge Adaptor (AD24), 5/8"	All 20 lb Alum. Valve	
N/S	HTAA3	Hydrotest Adapter - 1"-12 UNF	All Alum. Valve	
N/S	A1521	Wall Hanger Bracket, Red, 5 & 5 1/2lb. Alum Vlv Models	400, A400, A/B402X, 500, A/B500X, 453, A/B453, 479, A/B479	5 & 5 1/2lb. Models
N/S	A5525	Wall Hanger Bracket (Red) - All 6lb. & 10lb. Tall Aluminum Valve Models	443, A/B443, 456, A/B456X, A/B457	6 & 10lb. Models
N/S	WH1	Universal Wall Hanger for 2 1/2 Gal PW and Various Amerex Models	A411X, A412, A413	Pre-2004 Models
N/S	WH20	Universal Wall Hanger, 17-20, 30lb Extgrs	A411X, A412, A413	2004-present Models
N/S	VB4	Vehicle Bracket for 4 to 4 1/2" Dia. Shells	400, A400, A/B402X, 500, A/B500X, 453, A/B453, 479, A/B479	5 & 5 1/2lb. Models
N/S	VB5	Vehicle Bracket for 4 3/4" to 5 1/4" Dia. Shells	443, A/B443, 456, A/B456X, A/B457	6 & 10lb. Models
N/S	VB8	Vehicle Bracket for 6 3/4" to 7 1/4" Dia. Shells	A411X, A412, A413	20lb. Models

5 - 30 LB. Dry Chemical Brass Valve Model Accessories

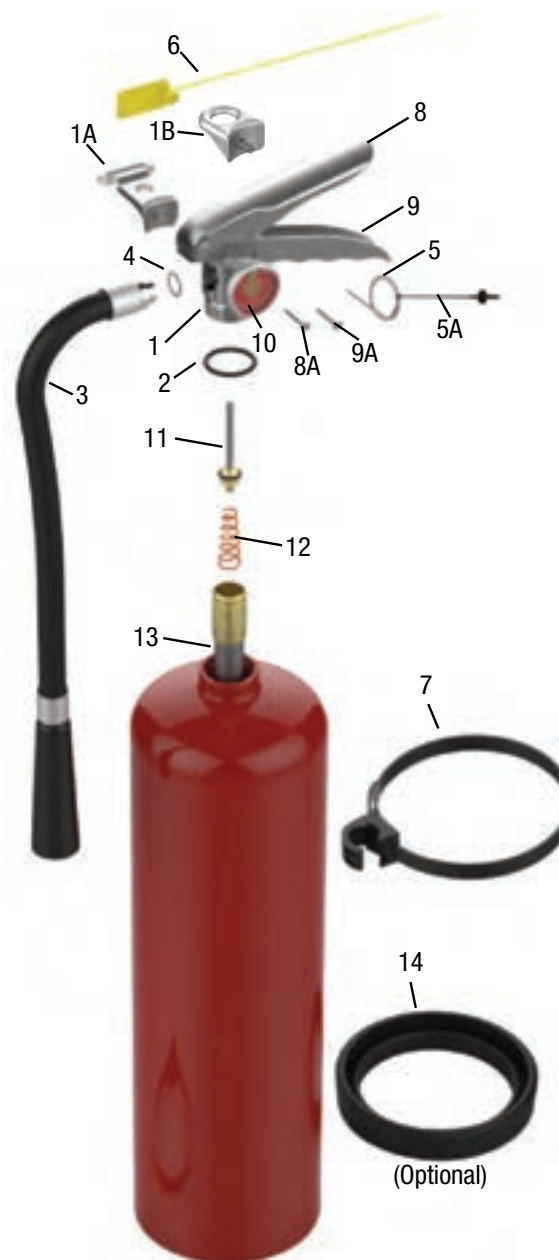
FIG.	PART#	DESCRIPTION	MODEL	NOTES
7	A15747	Strap & Hose Clip Ass'y (Black Plastic) 3/8"	ALL 4 1/4 & 5" Diameter Cylinders (5/6/10lb.)	
7	A14778	Strap & Clip Assembly (Black Plastic) 1/2"	ALL 7" Diameter Cylinders (20lb.)	
7	A14871	Strap & Hose Clip Ass'y (Black Plastic) 1/2"	ALL 8" Diameter Cylinders (30lb.)	
N/S	UHS34	Universal Hose Strap, 34", Black		
N/S	UHC	Hose Clip for use with UHS34		
14	A12383	Protective Ring for Bottom of Cylinder - 7"	20lb.	
14	A12952	Protective Ring for Bottom of Cylinder - 8"	30lb.	
N/S	RA11	Recharge Adaptor (AD24), 5/8"	All Brass Valve	
N/S	HTAA1	Hydrotest Adapter - 1 1/4"-12 UNF	All Brass Valve	
N/S	WH1	Universal Wall Hanger for 2 1/2 Gal PW and Various Amerex Models	408X, 415, 419X, 423X	Pre-2004 Models
N/S	WH20	Universal Wall Hanger, 17-20, 30lb Extgrs	408X, 415, 419X, 423X	2004 or later Models
N/S	WH1	Universal Wall Hanger for 2 1/2 Gal PW and Various Amerex Models	424X, B424X, 441X, B441X, 447X, B447X, 460, B460, 461, 462	
N/S	WH5	Universal Wall Hook for 5, 6lb. Extgrs	B461, B462	
N/S	WH20	Universal Wall Hanger, 17-20, 30lb Extgrs	692X, 693X	
N/S	VB4	Vehicle Bracket for 4 to 4 1/2" Dia. Shells	424X, B424X	
N/S	VB5	Vehicle Bracket for 4 3/4" to 5 1/4" Dia. Shells	461, B461, 462, B462, 441X, B411X, 447X, B447X, 460, B460	
N/S	VB6	Vehicle Bracket for 5 1/8" to 6" Dia. Shells	419X	
N/S	VB8	Vehicle Bracket for 6 3/4" to 7 1/4" Dia. Shells	423X, 408X, 415	
N/S	VB9	Vehicle Bracket for up to 8" Dia. Shells	692X, 693X	

**5 - 30 LB. DRY CHEMICAL
BRASS VALVE MODELS**



424X - 5lb. ABC	B462 - 6lb. REG	B447X - 10lb. REG	408X - 20lb. REG
B424X - 5lb. ABC	419X - 10lb. ABC	460 - 10lb. PK	415 - 20lb. PK
461 - 6lb. ABC	441X - 10lb. ABC	B460 - 10lb. PK	692X - 30lb. ABC
B461 - 6lb. ABC	B441X - 10lb. ABC	423X - 20lb. ABC	693X - 30lb. PK
462 - 6lb. REG	447X - 10lb. REG		

FIG.	PART#	DESCRIPTION	MODEL
1	A11952*	Valve Assembly	All
1A	A15363	Hanger Loop with Screw	"B" Models: B441X, B447, B460 (10lb.)
1B	A16694	Hanger Loop with Screw	5lb., 6lb., & 20lb.
1B	A17144	Hanger Loop with Screw	692X, 693X
2	OR215	Collar O-Ring, Generic (OEM# A5240)	All
3	A3753	Hose & Horn Ass'y (.140)	424X, B424X
3	A1178	Hose & Horn Ass'y (.173)	441X, 447X-B447X
3	A3753	Hose & Horn Ass'y (.140)	461-B461, 462-B462
3	A6095	Hose & Horn Ass'y (.152)	419X, 460-B460, B441X
3	A3339	Hose & Horn Ass'y (.174)	423X
3	A5174	Hose & Horn Ass'y (.177)	415
3	A3332	Hose & Horn Ass'y (.173)	408X
3	A12603	Hose & Horn Ass'y (.216)	692X
3	A13439	Hose & Horn Ass'y (.191)	693X
4	OR10	Hose Gasket (O-Ring), Generic (OEM# A6978)	All
5	SPP	Ring Pin	All
5A	A532	Chain (Nylon) for Ring Pin	All
6	TSY	Medium Flag Tamper Seal, Yellow	All
8	A7762	Lever & Rivet	All
8A	A1563	Rivet Only for Lever	All
9	A9020	Handle & Rivets	All
9A	RV5	Rivet Only for Handle, Generic (OEM# A1564) 2 Required	All
10	G195	Gauge - 195 PSI	All
11	A6093	Valve Stem Assembly	All
12	A383	Spring	All
13	A1696	Downtube/Retainer Ass'y	424X, B424X (5lb.)
13	A1700	Downtube/Retainer Ass'y	419X (10lb. Short)
13	A3754	Downtube/Retainer Ass'y	461-B461, 462-B462 (6lb.)
13	A2609	Downtube/Retainer Ass'y	441X-B441X, 447X-B447X, 460-B460 (10 lb. Tall)
13	A1667	Downtube/Retainer Ass'y	408X, 415, 423X (20lb.)
13	A9583	Downtube/Retainer Ass'y	692X, 693X (30lb.)



***NOTE 1: All Valve Assemblies include Valve Body, Gauge, Lever and Handle**



10 - 20 LB. HIGH FLOW DRY CHEMICAL BRASS VALVE MODELS

720 - 10lb. ABC 722 - 10lb. PK 761 - 20lb. REG
 721 - 10lb. REG 760 - 20lb. ABC 762 - 20lb. PK



FIG.	PART#	DESCRIPTION	MODEL
1	A11952*	Valve Assembly	All
1A	A15363	Hanger Loop with Screw	720, 721, 722 (10 lb.)
1B	A16694	Hanger Loop with Screw	760,761,762 (20 lb.)
2	OR215	Collar O-Ring, Generic (OEM# A5240)	All
3	A20914	Hose & Horn Ass'y	720 (.312)
3	A20908	Hose & Horn Ass'y	721 , 722 (.250)
3	A20912	Hose & Horn Ass'y	760 (.266)
3	A14044	Hose & Horn Ass'y	761 (.234)
3	A20910	Hose & Horn Ass'y	762 (.228)
4	OR10	Hose Gasket (O-Ring), Generic (OEM# A6978)	All
5	LSP	Ring Pin, Stainless Steel	All
5A	A532	Chain (Nylon) for Ring Pin	All
6	TSY	Medium Flag Tamper Seal, Yellow	All
8	A7762	Lever & Rivet	All
8A	A1563	Rivet Only for Lever	All
9	A9020	Handle & Rivets	All
9A	RV5	Rivet Only for Handle, Generic (OEM# A1564) 2 Required	All
10	G195	Gauge - 195 PSI	All
11	A6093	Valve Stem Assembly	All
12	A383	Spring	All
13	A1667	Downtube/Retainer Ass'y	760, 761, 762 (20 lb.)
13	A2609	Downtube/Retainer Ass'y	720, 721, 722 (10 lb.)

***NOTE 1: All Valve Assemblies include Valve Body, Gauge, Lever and Handle**

ACCESSORIES

FIG.	PART#	DESCRIPTION	MODEL	NOTES
7	A14778	Strap & Clip Assembly (Black Plastic) ½"	All 7" Diameter Cylinders (20 lb.)	
N/S	UHS34	Universal Hose Strap, 34", Black		
N/S	UHC	Hose Clip for use with UHS34		
14	A12383	Protective Ring for Bottom of Cylinder - 7"	20 lb.	
N/S	HTAA1	Hydrotest Adapter - 1¼"-12 UNF	All Brass Valve	
N/S	RA11	Recharge Adaptor (AD24), 5/8"	All, Except for Male Threaded Valves	
N/S	A9492	Recharge Adaptor for Male Thread Vlv - ½" - 14 NPSL	Male Threaded Valves	Adaptor has female end
N/S	WH1	Universal Wall Hanger for 2½ Gal PW and Various Amerex Models	720, 721, 722	
N/S	WH20	Universal Wall Hanger, 17-20, 30 lb Extgrs	760, 761, 762	
N/S	VB5	Vehicle Bracket for 4¾" to 5¼" Dia. Shells	720, 721, 722	
N/S	VB8	Vehicle Bracket for 6¾" to 7¼" Dia. Shells	760, 761, 762	



**1¾ - 2½ GAL. WATER MIST
EXTINGUISHER MODELS**

270 / B270 / 270NM / 270CG - 1¾ gal.

272X / B272 / 272NM / 272CG - 2½ gal.



FIG.	PART#	DESCRIPTION	MODEL
1	A17615*	Valve Assembly	All
2	A14380	Hanger Loop with Screw (Optional)	All
3	A14184	Hose & Wand Assembly	272X, B272, 272NM, B272CG
3	A14318	Hose & Wand Assembly	270, B270, 270NM, B270CG
4	LSP	Ring Pin, Stainless Steel	All Non-Magnetic
4	A6901	Ring Pin, Stainless Steel (Non-Magnetic)	270NM, 272NM
4A	A532	Chain (Nylon) for Ring Pin	All
5	TSY	Medium Flag Tamper Seal, Yellow	All
6	A7762	Lever & Rivet	All
6A	A1563	Rivet Only for Lever	All
7	A9020	Handle & Rivets	All
7A	RV5	Rivet Only for Handle, Generic (OEM# A1564)	All
8	OFG100	Gauge - 100 PSI (Oil Filled)	All
9	OR215	Collar O-Ring, Generic (OEM# A5240)	All
10	A6093	Valve Stem Assembly	All
11	A383	Spring	All
12	A15943	Downtube/Retainer Ass'y	272X, B272, 272NM, B272CG
12	A15941	Downtube/Retainer Ass'y	270, B270, 270NM, B270CG
13	A5690	O-Ring Downtube / Retainer	All
14	A2595	Fill Tube (Black)	272X, B272
14	A14316	Fill Tube (Red)	270, B270



***NOTE 1: All Valve Assemblies include Valve Body, Gauge, Collar Nut, O-Ring, Lever and Handle**

ACCESSORIES

FIG.	PART#	DESCRIPTION	MODEL	NOTES
15	A14187	Foot Stand (Blue)		
16	A14838	Strap & Clip Ass'y [Blue Plastic - ¾"]		(2 Required)
17	A21777	Rubber Footstand 7"		Discontinued
17	A21854	Rubber Footstand Adhesive (Not Shown)		
N/S	HTAA2	Hydrotest Adapter - 1½"	All	
N/S	A9492	Recharge Adaptor for Male Thread Vlv - ½" - 14 NPSL	All	Adaptor has female end
N/S	A14315	Wall Hanger Bracket (Stainless Steel), Non-Magnetic	All	
N/S	A671	2½ Gal. deionized water charge for 272X		



6 LITER AND 2½ GAL. WET CHEMICAL MODELS

260 / B260X / B260CG - 6 Liter

262 / B262 / B262CG - 2½ gal.

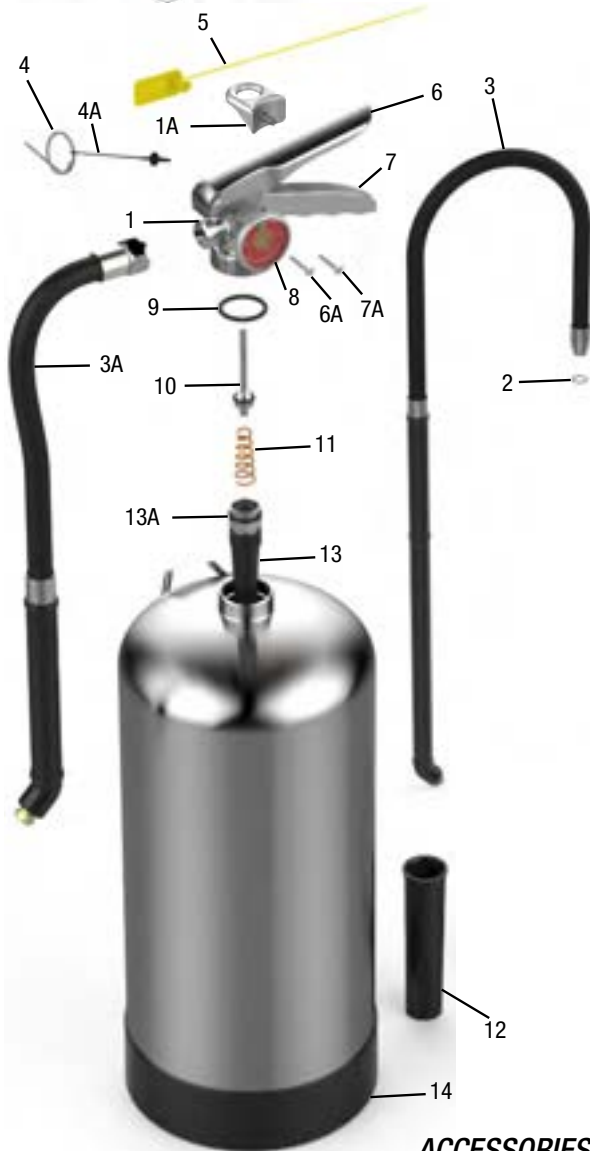


FIG.	PART#	DESCRIPTION	MODEL
1	A14345*	Valve Assembly	260, 262
1	A14249*	Valve Assembly	B260, B260CG, B262, B262CG
1A	A14380	Hanger Loop with Screw (Optional)	All
2	OR10	Hose Gasket (O-Ring), Generic (OEM# A6978)	260, 262
3	A14588	Hose & Wand Assembly	260, 262
3A	A16043	Hose & Nozzle Assembly	B260X, B260CG
3A	A16101	Hose & Nozzle Assembly	B262, B262CG
4	LSP	Ring Pin, Stainless Steel	All
4A	A532	Chain (Nylon) for Ring Pin	All
5	TSY	Medium Flag Tamper Seal, Yellow	All
6	A7762	Lever & Rivet	All
6A	A1563	Rivet Only for Lever	All
7	A9020	Handle & Rivets	All
7A	RV5	Rivet Only for Handle, Generic (OEM# A1564)	All
8	G100K	Gauge - 100 PSI	All
9	OR215	Collar O-Ring, Generic (OEM# A5240)	All
10	A14878	Valve Stem Assembly	All
11	A383	Spring	All
12	A2595	Fill Tube	All
13	A16266	Downtube/Retainer Ass'y	260, B260X, B260CG
13	A16267	Downtube/Retainer Ass'y	262, B262, B262CG
13A	A5690	O-Ring Downtube / Retainer	All

***NOTE 1: All Valve Assemblies include Valve Body, Gauge, Collar Nut, O-Ring, Lever and Handle**

ACCESSORIES

FIG.	PART#	DESCRIPTION	MODEL	NOTES
14	A3109	Foot Stand (Black)		
15	A14776	Strap & Clip Ass'y [Black Plastic - ¾"]		
16	RP189	K-Class "Fire Extinguisher" Arrow, Bilingual, 8" x 12"		
17	A21777	Rubber Footstand 7"		Discontinued
17	A21854	Rubber Footstand Adhesive (Not Shown)		
N/S	HTAA2	Hydrotest Adapter - 1½"	All	
N/S	RA11	Recharge Adaptor (AD24), ⅝"	All, Except Male Threaded Vlv	
N/S	A9492	Recharge Adaptor for Male Thread Vlv - ½" - 14 NPSL	B260X, B262 Male Threaded Vlv	Adaptor has female end
N/S	WH1	Universal Wall Hanger for 2½ Gal PW and Various Amerex Models	All	
N/S	VB8	Vehicle Bracket for 6¾" to 7¼" Dia. Shells	All	
N/S	AX530	6 Litre Recharge for B260X	B260X	



6 LITER AND 2½ GAL. WATER & FOAM MODELS

240X - 2½ Gallon Water 252X - 2½ Gallon FFFP Foam
 250 / 250X - 2½ Gallon AR-AFFF Foam 254 - 6 Liter AR-AFFF Foam



FIG.	PART#	DESCRIPTION	MODEL
1	A13281*	Valve Assembly	240X w/ air valve
1	A17616*	Valve Assembly	250, 250X, 252X, 254 w/o air valve
1A	A14380	Hanger Loop with Screw (Optional on Foam)	240X
2	OR10	Hose Gasket (O-Ring), Generic (OEM# A6978)	All
3	A6999	Hose & Nozzle Assembly	240X
3A	A7000	Hose & Aspirated Black Nozzle Assembly	250, 250X
3A	A6982	Hose & Aspirated Gray Nozzle Assembly	252X
3B	A13162	Hose & Spray Nozzle Assembly	254
4	AVA	Pressure Valve & Cap Assembly	240 Only
5	LSP	Ring Pin, Stainless Steel	All
5A	A532	Chain (Nylon) for Ring Pin	All
6	TSY	Medium Flag Tamper Seal, Yellow	All
7	A7762	Lever & Rivet	All
7A	A1563	Rivet Only for Lever	All
8	A9020	Handle & Rivets	All
8A	RV5	Rivet Only for Handle, Generic (OEM# A1564) 2 Required	All
9	OFG100	Gauge - 100 PSI (Oil Filled)	All
10	OR215	Collar O-Ring, Generic (OEM# A5240)	All
11	A6093	Valve Stem Assembly	All
12	A383	Spring	All
13	A2595	Fill Tube	All
14	A5690	O-Ring Downtube / Retainer	All
15	A15943	Downtube/Retainer Ass'y	240X, 250, 250X, 252X
15	A15941	Downtube/Retainer Ass'y	254

***NOTE 1: All Valve Assemblies include Valve Body, Gauge, Collar Nut, O-Ring, Lever and Handle**



ACCESSORIES

FIG.	PART#	DESCRIPTION	MODEL
16	A3576	Foot Stand with Clip (Black)	240X
16	A3776	Foot Stand with Post (Black)	250, 250X, 252X
16	A3109	Foot Stand (Black)	254
17	A14776	Strap & Clip Assembly	254 Only
18	A21777	Rubber Footstand 7"	All
N/S	A21854	Rubber Footstand Adhesive	All
N/S	HTAA2	Hydrotest Adapter - 1½"	All
N/S	RA11	Recharge Adaptor (AD24), 5/8"	All
N/S	AVA	Pressure Valve & Cap Assembly	240X
N/S	WH1	Universal Wall Hanger for 2½ Gal PW and Various Amerex Models	All
N/S	VB8	Vehicle Bracket for 6¾" to 7¼" Dia. Shells	All
N/S	AC40	Anti-Freeze Charge (1 per Extgr)	240X
N/S	A2117	AR-AFFF foam recharge	254, 250X

Discontinued



**6 KG - 30 LB. DRY CHEMICAL
HIGH PERFORMANCE MODELS**

- | | | | |
|---------------------|--------------------|--------------------|-------------------|
| 564X - 20lb. ABC CF | 569 - 30lb. PK FF | 584 - 20lb. PK FF | 594 - 6kg. ABC FF |
| 566X - 20lb. PK FF | 580 - 20lb. PK FF | 589 - 30lb. ABC CF | 595 - 6kg. PK FF |
| 567 - 30lb. ABC FF | 581 - 20lb. ABC FF | 591X - 30lb. PK CF | 599 - 6kg. PK CF |
| 568 - 30lb. REG FF | 582 - 20lb. REG FF | 592 - 6kg. ABC CF | |

FIG.	PART#	DESCRIPTION	MODEL
1	A14874*	Valve Assembly - (Female Outlet Thread)	All
2	OR215	Collar O-Ring, Generic (OEM# A5240)	All
3	A14785	Hose & Horn Assembly (.213)	594
3	A14791	Hose & Horn Assembly (.204)	595
3	A14788	Hose & Horn Assembly (.250)	580, 581, 582
3	A14790	Hose & Horn Assembly (.166)	592
3	A14794	Hose & Horn Assembly (.149)	599
3	A14787	Hose & Horn Assembly (.166)	564X
3	A14786	Hose & Horn Assembly (.157)	566X
3	A14789	Hose & Horn Assembly (.312)	567, 568, 569, 584
3	A14947	Hose & Horn Assembly (.213)	589
3	A14948	Hose & Horn Assembly (.180)	591X
3A	A14778	Strap & Clip Assembly (Black Plastic) ½" Hose	6kg (13.2 lb.) & 20 lb.
3A	A14871	Strap & Clip Assembly (Black Plastic) ½" Hose	30 lb.
4	OR10	Hose Gasket (O-Ring), Generic (OEM# A6978)	All
5	LSP	Ring Pin, Stainless Steel	All
6	A532	Chain (Nylon) for Ring Pin	All
7	TSY	Medium Flag Tamper Seal, Yellow	All
8	A9584	Hanger Loop with Screw	All
9	A9840	Lever & Rivet	All
9A	A1563	Rivet Only for Lever	All
10	A9020	Handle & Rivets	All
10A	RV5	Rivet Only for Handle, Generic (OEM# A1564) 2 Required	All
11	G240	Gauge - 240 PSI	All
12	A9102	Gauge Guard, Chrome Plated Brass	All
13	A6093	Valve Stem Assembly	All
14	A383	Spring	All
15	A1700	Downtube/Retainer Ass'y	6kg (13.2 lb.)
15	A1667	Downtube/Retainer Ass'y	20 lb.
15	A9583	Downtube/Retainer Ass'y	30 lb.

ACCESSORIES

FIG.	PART#	DESCRIPTION	MODEL	NOTES
16	A12383	Protective Foot Ring for Bottom of Cylinder 7" Dia.	20lb. & 6kg. (13.2lb.)	
16	A12952	Protective Foot Ring for Bottom of Cylinder 8" Dia.	30 lb.	
N/S	HTAA1	Hydrotest Adapter - 1¼"-12 UNF	All Brass Valve	
N/S	RA11	Recharge Adaptor (AD24), 5/8"	All, Except for Male Threaded Valves	
N/S	A9492	Recharge Adaptor for Male Thread Vlv - ½" - 14 NPSL	Male Threaded Valves	Adaptor has female end
N/S	A9582	Wall Hanger Bracket, Red, All 13.2 (6kg.) and 20 lb. High Perf	592, 594, 595, 599, 564X, 566X, 580, 581, 582, 584	
N/S	A9581	Wall Hanger Bracket, Red, 30 lb. High Perf	567, 568, 569	
N/S	VB8	Vehicle Bracket for 6¾" to 7¼" Dia. Shells	564X, 566X, 594, 580, 581, 582, 584, 592, 595, 599	All 6kg, 20 lb.
N/S	VB9	Vehicle Bracket for up to 8" Dia. Shells	567, 568, 569, 589, 591	All 30 lb.

***NOTE 1: All Valve Assemblies include Valve Body, Gauge, Gauge Guard, Hanger Loop, Lever and Handle**

NOTE 2: Hose assemblies for older extinguishers utilizing a swivel type connector are no longer available. Order valve assembly 14874 and hose listed above for that model.

**1¼ - 20 LB. HALON 1211
EXTINGUISHER MODELS**

344 - 1¼ lb. A/C352 - 2½ lb. 355 - 5 lb. 369 - 9 lb. B371 - 13 lb. 372 - 20 lb.
 A344 - 1¼ lb. 354 - 3 lb. A355 - 5 lb. B369 - 9 lb. 361 - 17 lb. B372 - 20 lb.
 352 - 2½ lb. A/C354 - 3 lb. B355 - 5 lb. 371 - 13 lb. B361 - 17 lb.



FIG.	PART#	DESCRIPTION	MODEL
1	A11953*	Valve Assembly	Aluminum Models (Except 344, A344)
1A	A11954*	Valve Assembly	All Brass Models
2	A6066	Nozzle with O-Ring (.067)	344, A344
2	A7115	Nozzle with O-Ring (.098)	352, A/C352
2	A1727	Nozzle with O-Ring (.144)	355, A/B355
2A	A1532	Hose/Nozzle Gasket (O-Ring)	Aluminum Valve
2B	OR10	Hose Gasket (O-Ring), Generic (OEM# A6978)	Brass Valve
2C	A6421	Hose & Horn Assembly (.098)	354, A/C354
2D	A5180	Hose & Horn Assembly (.216)	369, B369
2D	A5178	Hose & Horn Assembly (.234)	371, B371
2D	A5176	Hose & Horn Assembly (.152)	361
2D	A5174	Hose & Horn Assembly (.177)	372
3	A16268	Ring Pin	1¼ lb., 2½ lb.
3A	LSP	Ring Pin, Stainless Steel	All
3B	A532	Chain (Nylon) for Ring Pin	All
4	TSY	Medium Flag Tamper Seal, Yellow	All
5	A11825	Lever & Rivet	All
5A	A1060	Rivet Only for Lever	Aluminum Valve
5B	A2625	Lever & Rivet	Modified Valve
5C	A7762	Lever & Rivet	Brass Valve
5D	A1563	Rivet Only for Lever	Brass Valve
6	HG100	Gauge - 100 PSI (Halon)	344, A344
6	A3105	Gauge - 125 PSI (Halon)	352, A/C352, 355, A/B355
6	G195H	Gauge - 195 PSI (Halon)	354, A/C354, B361, 369, B369, 371, B371, 372
7	A11826	Handle & Rivet	All
7A	RV5	Rivet Only for Handle, Generic (OEM# A1064)	Aluminum Valve
7B	A9001	Handle & Rivet	Modified Valve
7C	A9020	Handle & Rivet	Brass Valve
7D	RV5	Rivet Only for Handle, Generic (OEM# A1564) 2 Required	Brass Valve
8	OR212	Collar O-Ring, Generic (OEM# A5241)	Aluminum Valve
8A	OR215	Collar O-Ring, Generic (OEM# A5240)	Brass Valve
9	A6092	Valve Stem Assembly	Aluminum Valve
9A	A6093	Valve Stem Assembly	Brass Valve
10	A1074	Spring	Aluminum Valve

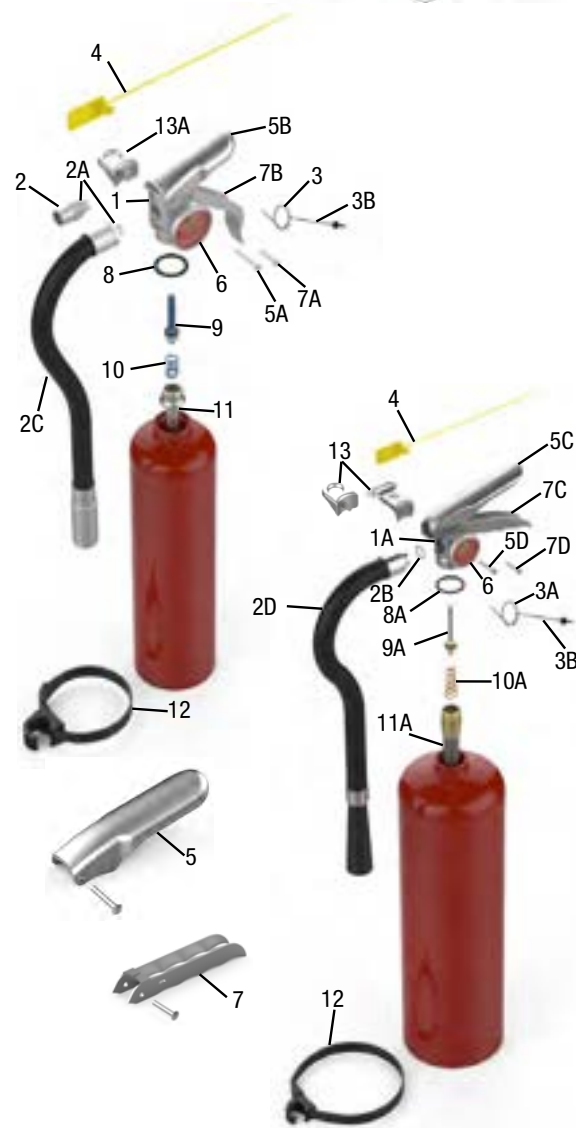


FIG.	PART#	DESCRIPTION	MODEL
10A	A383	Spring	Brass Valve
11	A6069	Downtube/Retainer Ass'y	344, A344
11	A1075	Downtube/Retainer Ass'y	352, A/C352, 354
11	A6212	Downtube/Retainer Ass'y	355, A/B355
11A	A3754	Downtube/Retainer Ass'y	369, B369
11A	A2609	Downtube/Retainer Ass'y	371, B371
11A	A1667	Downtube/Retainer Ass'y	B361, B372
13	A15363	Hanger Loop with Screw	B371
13	A16694	Hanger Loop with Screw	361, B369, 372
13A	A14220	Hanger Loop with Screw	Aluminum Valve

***NOTE 1: All Valve Assemblies include Valve Body, Gauge, Lever and Handle (Loop and Screw 11953)**

1¼ - 20 lb. Halon 1211 Extinguisher Model Accessories

FIG.	PART#	DESCRIPTION	MODEL	NOTES
12	A15747	Strap & Clip Assembly (Black Plastic) ⅜" Hose	354, A/C354	
12	A14778	Strap & Clip Assembly (Black Plastic) ½" Hose	361, 372, 369, B369, 371, B371	
N/S	RA16	Recharge Adaptor (AD21), ⅜"	344, A344, 352, A/C352, 354, A/C354, 355, A355, B355	All Alum. Valve (1¼ to 5 lb.)
N/S	RA11	Recharge Adaptor (AD24), ⅝"	369, B369, 371, B371, 361, B361, 372, B372	All Brass Valve (9 to 20 lb.)
N/S	HTAA3	Hydrotest Adapter - 1"-12 UNF	344, A344, 352, A/C352, 354, A/C354, 355, A355, B355	All Alum. Valve
N/S	HTAA1	Hydrotest Adapter - 1¼"-12 UNF	369, B369, 371, B371, 361, B361, 372, B372	All Brass Valve
N/S	A4834	Wall Hanger Bracket, Red, 1 lb. to 3 lb. Alum Vlv Models	344, A344, 352, A/C352, 354, A/C354	
N/S	A1521	Wall Hanger Bracket, Red, 5 & 5½ lb. Alum Vlv Models	355, A355, B355	
N/S	WH1	Universal Wall Hanger for 2½ Gal PW and Various Amerex Models	361, 372	Pre-2004 Models
N/S	WH1	Universal Wall Hanger for 2½ Gal PW and Various Amerex Models	369, B369, 371, B371	
N/S	WH20	Universal Wall Hanger, 17-20, 30 lb Extgrs	361, B361, 372, B372	
N/S	VB4	Vehicle Bracket for 4 to 4½" Dia. Shells	355, A355, B355	
N/S	VB5	Vehicle Bracket for 4¾" to 5¼" Dia. Shells	369, B369, 371, B371	
N/S	VB8	Vehicle Bracket for 6¾" to 7¼" Dia. Shells	361, B361, 372, B372	

1.4 lb. - 15½ lb. Halotron I Extinguisher Model Accessories

FIG.	PART#	DESCRIPTION	MODEL	NOTES
17	A14778	Strap & Clip Assembly (Black Plastic) ½" Hose	387, 388, 397, 398	
N/S	RA16	Recharge Adaptor (AD21), ⅜"	All 5 and 10 lb. Alum. Valve	All Alum. Valve
N/S	RA11	Recharge Adaptor (AD24), ⅝"	All 20 lb Alum. Valve	All Brass Valve
N/S	HTAA3	Hydrotest Adapter - 1"-12 UNF	A384, A385, B385, A386, B386, B394	All Alum. Valve (1.4 to 5½ lbs.)
N/S	HTAA1	Hydrotest Adapter - 1¼"-12 UNF	387, 397, 388, 398	All Brass Valve (11 to 15½ lbs.)
N/S	VB4	Vehicle Bracket for 4 to 4½" Dia. Shells	A386, B386, B394	
N/S	VB6	Vehicle Bracket for 5½" to 6" Dia. Shells	387, 388, 397, 398	

10 - 20 lb. Carbon Dioxide Extinguisher Models Accessories

FIG.	PART#	DESCRIPTION	MODEL
18	A20570	Strap & Clip	330X, 331X
18	A20571	Strap & Clip	332X
N/S	ARD	10-20 lb. CO2 Alum. Replacement Band for use with Rapid Discharge Horn	330X, 331X
N/S	SET2	Hardware for ARD (Spacer/Nut/Screw/Washer)	330X, 331X, 332X
N/S	BL209	Vinyl Nameplate 5lbs. CO2 Instruction	330X, 331X, 332X
N/S	FBL209	Vinyl Nameplate 5lbs. CO2 Instruction - French version	330X, 331X, 332X
N/S	BL210	Vinyl Nameplate Large CO2 Instruction	330X, 331X, 332X
N/S	FBL210	Vinyl Nameplate Large CO2 Instruction - French version	330X, 331X, 332X
N/S	HPTA27	Hydrotest Adapter	All
N/S	WH10	Universal Wall Hook, 10-15 lb. Extgrs	330X, 331X
N/S	WH20	Universal Wall Hanger, 17-20, 30 lb Extgrs	332X
N/S	VB8	Vehicle Bracket for 6¾" to 7¼" Dia. Shells	330X, 331X
N/S	VB9	Vehicle Bracket for up to 8" Dia. Shells	332X

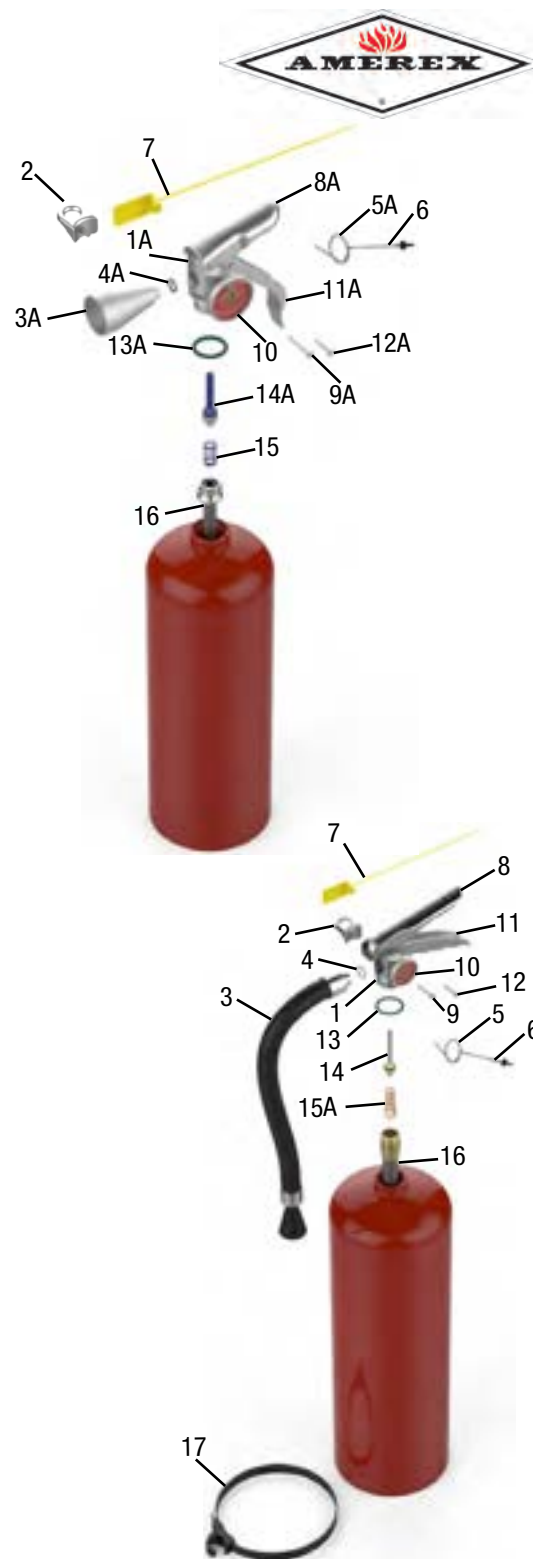
FOR CO2 TEST ADAPTORS SEE THE SERVICE EQUIPMENT SECTION/CATEGORY

**1.4 LB. - 15½ LB. HALOTRON I
EXTINGUISHER MODELS**

A384 - 1.4 lb. B385 - 2½ lb. B386 - 5 lb. 387 - 11lb. 388 - 15½ lb.

A385 - 2½ lb. A386 - 5 lb. B394 - 5½ lb. 397 - 11lb. 398 - 15½ lb.

FIG.	PART#	DESCRIPTION	MODEL
1	A14527*1	Valve Assembly	387, 388, 397, 398
1A	A14525*1	Valve Assembly	384
1A	A14526*2	Valve Assembly	385, B385, 386, B386
1A	A16331*3	Valve Assembly	B394
2	A14220	Hanger Loop with Screw	384,A/B385, A/B386, B394
2	A16694	Hanger Loop with Screw	387, 388, 397, 398
3	A14436	Hose & Nozzle Assembly	387, 397 (.247)
3	A14449	Hose & Nozzle Assembly	388, 398, (.295)
3A	A14407	Nozzle (.121)	384
3A	A14408	Nozzle (.166)	A/B385
3A	A14409	Nozzle (.277)	A/B386, B394
4	OR10	Hose Gasket (O-Ring), Generic (OEM# A6978)	Brass Valve
4A	A1532	O-Ring, Nozzle	Aluminum Valve
5	LSP	Ring Pin, Stainless Steel	5 to 15½ lb.
5A	A16268	Ring Pin	1¼ lb., 2½ lb.
6	A532	Chain (Nylon) for Ring Pin	All
7	TSY	Medium Flag Tamper Seal, Yellow	All
8	A7762	Lever & Rivet	Brass Valve
8A	A2625	Lever & Rivet	Modified Aluminum Valve
8A	A11825	Lever & Rivet	Aluminum Valve
9	A1563	Rivet Only for Lever	Brass Valve
9A	A1060	Rivet Only for Lever	Aluminum Valve
10	G125T	Gauge - 125 PSI (Halotron I)	384, 387, 388, 397, 398
10	G100T	Gauge - 100 PSI (Halotron I)	A/B385, A/B386
10	A16332	Gauge - 150 PSI	B394
11	A9020	Handle & Rivets	387, 388, 397, 398
11A	A9001	Handle & Rivet	Modified Aluminum Valve
11A	A11826	Handle & Rivet	Aluminum Valve
12	RV5	Rivet Only for Handle, Generic (OEM# A1564) 2 Required	Brass Valve
12A	RV5	Rivet Only for Handle, Generic (OEM# A1064)	Aluminum Valve
13	A13305	Collar O-Ring (Green)	Brass Valve
13A	A14268	Collar O-Ring (Green)	Aluminum Valve
14	A13288	Valve Stem Assembly (Green Seal)	Brass Valve
14A	A14327	Valve Stem Assembly (Green Seal)	Aluminum Valve
15	A1074	Spring	Aluminum Valve
15A	A383	Spring	Brass Valve
16	A6069	Downtube/Retainer Ass'y	384
16	A1075	Downtube/Retainer Ass'y	385
16	A6212	Downtube/Retainer Ass'y	A/B386, B385, B394
16	A15507	Downtube/Retainer Ass'y	397, 398



***NOTE 1: All Valve Assemblies include New Valve Body, Gauge, Lever and Handle**
***NOTE 2: All Valve Assemblies include New Valve Body, Gauge, Lever and Handle, Hanger Loop and Screw**
***NOTE 3: All Valve Assemblies include New Valve Body, Gauge, Lever and Handle, and Downtube**



**2½ / 5 LB. CARBON DIOXIDE
EXTINGUISHER MODELS**

320 - 2½ lb. 321 - 2½ lb. 322X - 5 lb. NM - Non Magnetic
320NM - 2½ lb. 321M - 2½ lb. 322NM - 5 lb. M - Military

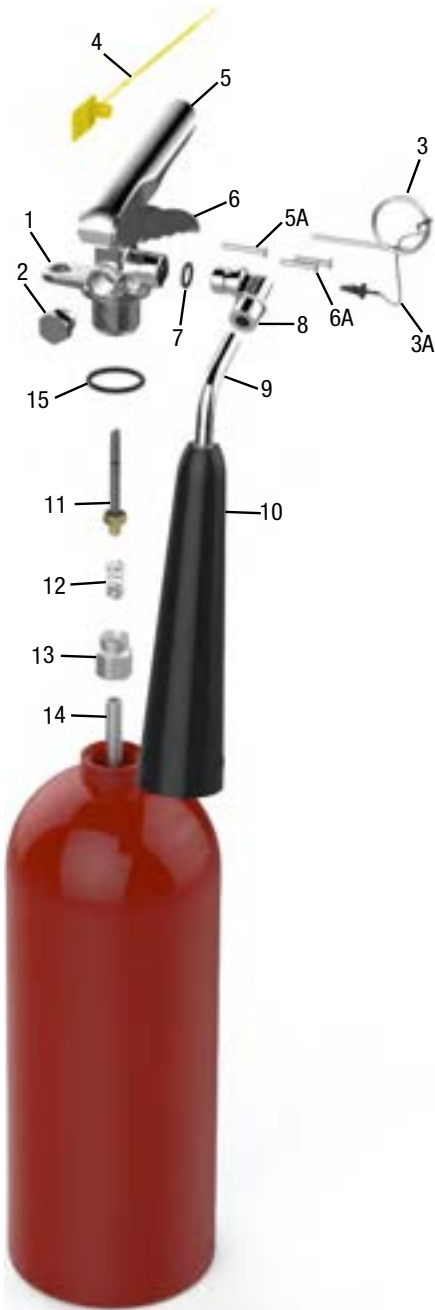


FIG.	PART#	DESCRIPTION	MODEL
1	A3090*	Valve Assembly	322X
1	A22403*	Valve Assembly	320
1	A22455*	Valve Assembly	321M
2	A4000	Safety Disc, Gasket and Nut Assembly	320, 322X
2	A22895	Safety Disc, Gasket and Nut Assembly	321M
3	LSP	Ring Pin, Stainless Steel	322X
3	A6901	Ring Pin, Stainless Steel Non-Magnetic	320NM, 322NM
3	A16268	Ring Pin, Stainless Steel (Small)	320, 321, 321M
3A	A532	Chain (Nylon) for Ring Pin	All
4	TSY	Medium Flag Tamper Seal, Yellow	All
5	A7762	Lever & Rivet	322X
5	A23076	Lever & Rivet	320, 321M
5A	A1563	Rivet Only for Lever	All
6	A9020	Handle & Rivets	322X
6	A23077	Handle & Rivets	320, 321M
6A	RV5	Rivet Only for Handle, Generic (OEM# A1564) 2 Required	All
7	A5689	O-Ring for Elbow	All
7	OR111	O-Ring for Elbow, Generic (OEM# A5689)	All
8	A2735	Elbow with O-Ring	All
9	A1769	Discharge Tube	322X
9	A22582	Discharge Tube	320, 321M
10	A1772	Horn	322X
10	A22400	Horn	320, 321M
10	CH5D	Horn, 5 lb., Generic	322X
11	A1539	Valve Stem Assembly	All
12	A501	Spring	All
13	A503	Retainer	All
14	A533	Downtube	322X
14	A22443	Downtube	320, 321M
14	5SYP	C02 Downtube, 5 lb., Generic	322X
15	OR216A	Collar O-Ring - 1½", Generic (OEM# A1124)	All

***NOTE 1: All Valve Assemblies include Valve Body, Valve Stem Assembly, Spring, Retainer, Safety Disc, Lever and Handle
Does not include elbow or downtube**

ACCESSORIES

FIG.	PART#	DESCRIPTION	MODEL
N/A	HPTA27	Hydrotest Adapter	All
N/A	WH5	Universal Wall Hook for 5, 6 lb. Extgrs	322X
N/A	A22885	Wall Hanger Bracket, Non-Magnetic	320NM
N/A	A17737	Wall Hanger Bracket, Non-Magnetic	322NM
N/A	VB5	Vehicle Bracket for 4¾" to 5¼" Dia. Shells	322X

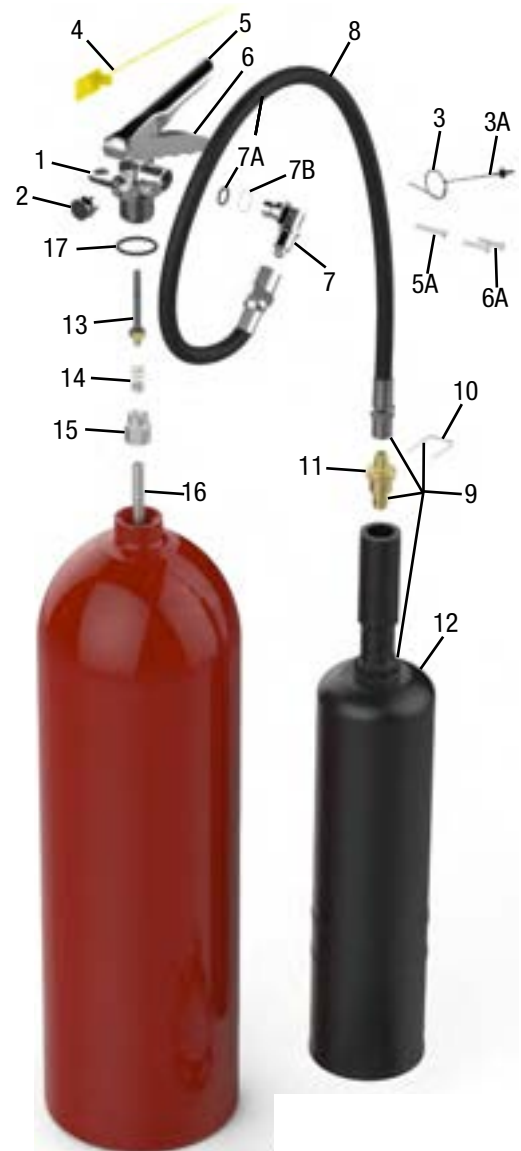
FOR CO2 TEST ADAPTORS SEE THE SERVICE EQUIPMENT SECTION/CATEGORY

**10 - 20 lb. CARBON DIOXIDE
EXTINGUISHER MODELS**

330X - 10 lb. 331X - 15 lb. 332X - 20 lb.



FIG.	PART#	DESCRIPTION	MODEL
1	A3090*	Valve Assembly	All
2	A4000	Safety Disc, Gasket and Nut Assembly	All
3	LSP	Ring Pin, Stainless Steel	All
3	A6901	Ring Pin, Stainless Steel Non Magnetic	All
3A	A532	Chain (Nylon) for Ring Pin	All
4	TSY	Medium Flag Tamper Seal, Yellow	All
5	A7762	Lever & Rivet	All
5A	A1563	Rivet Only for Lever	All
6	A9020	Handle & Rivets	All
6A	RV5	Rivet Only for Handle, Generic (OEM# A1564) 2 Required	All
7	A2309	Elbow with O-Ring and Spacer	All
7A	A5689	O-Ring for Elbow	All
7A	OR111	O-Ring for Elbow, Generic (OEM# A5689)	All
7B	A2216	Nylon Spacer for Elbow	All
8	A1776	Hose Assembly	All
8	362	36" CO2 Hose Assembly, 1/4" F x 3/8" F (OEM# A1776)	All
10	RDC	Clip for Rapid Discharge Horn	All
11	RDD	Diffuser Nozzle for Rapid Discharge Horn	All
12	RDH10	Rapid Discharge Horn, 10 lb., Generic (OEM# A572)	330X
12	RDH15	Rapid Discharge Horn, 15 lb., Generic (OEM# A593)	331X, 332X
13	A1539	Valve Stem Assembly	All
14	A501	Spring	All
15	A503	Retainer	All
16	10SYP	CO2 Downtube, 10 lb., Generic (OEM# A564)	330X
16	15SYP	CO2 Downtube, 15 & 20 lb., Generic (OEM# A589)	331X, 332X
17	OR216A	Collar O-Ring - 1 1/8", Generic (OEM# A1124)	All
	ARD	Aluminum 10 - 20 lbs. Rapid Discharge Horn Band	
	SET2	Hardware for ARD Band (Spacer/Nut/Screw & Washer)	



***NOTE 1: All Valve Assemblies include Valve Body, Stem Assembly, Spring, Retainer, Safety Disc, Lever and Handle
Does not include elbow or downtube**



**30 LB. CLASS D
EXTINGUISHER MODELS**

570 - Sodium Chloride (Super D) 571 - Copper

B570 - Sodium Chloride (Super D) B571 - Copper



FIG.	PART#	DESCRIPTION	MODEL
1	A11952*1	Valve Assembly	All
1A	A17144	Hanger Loop with Screw	B570, B571
2	OR215	Collar O-Ring, Generic (OEM# A5240)	All
3	A10744*2	Hose Ass'y w/ 1/2" Male Quick Connect	All
4	A10802	Female 1/2" Female Quick Connect	All
4A	A9073	O-Ring for Quick Connect	All
5	A10800*2	Extension Applicator	All
6	OR10	Hose Gasket (O-Ring), Generic (OEM# A6978)	All
7	LSP	Ring Pin, Stainless Steel	All
8	A532	Chain (Nylon) for Ring Pin	All
9	TSY	Medium Flag Tamper Seal, Yellow	All
10	A7762	Lever & Rivet	All
11	A1563	Rivet Only for Lever	All
12	A9020	Handle & Rivets	All
13	RV5	Rivet Only for Handle, Generic (OEM# A1564) 2 Required	All
14	G195	Gauge - 195 PSI	All
15	A6093	Valve Stem Assembly	All
16	A383	Spring	570, 571
16	A17139	Spring	B570, B571
17	A17215	Downtube/Retainer Ass'y	570, 571
17	A17214	Downtube/Retainer Ass'y	B570, B571

***NOTE 1: All Valve Assemblies include Valve Body, Gauge, Lever and Handle**
***NOTE 2: To replace old style hose use 10744 and 10800**

ACCESSORIES

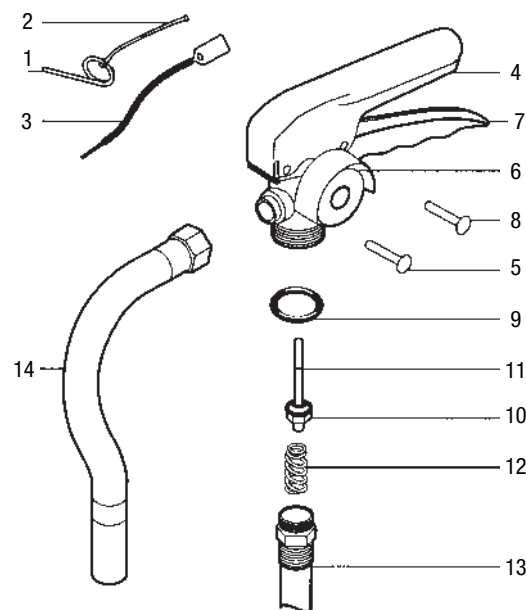
FIG.	PART#	DESCRIPTION	MODEL	NOTES
18	A23068	Strap & Clip	570, 571	
18	A20572	Strap & Clip	B570, B571	
19	A12383	Protective Ring for 7" Cylinder	570, 571	
19	A12952	Protective Ring for 8" Cylinder	B570, B571	
N/S	RA11	Recharge Adaptor (AD24), 5/8"	All	For Female Vlv Thread
N/S	HTAA1	Hydrotest Adapter - 1 1/4" - 12 UNF	All	
N/S	WH20	Universal Wall Hanger, 17-20, 30 lb Extgrs	All	
N/S	A545	Amerex Class D Powder, 50 lb. Pail Sodium Chloride	570	

DRY CHEMICAL HIGH PERFORMANCE

564 566 568 580 582 589 591X 595 592
 565 567 569 581 584 591 594 599



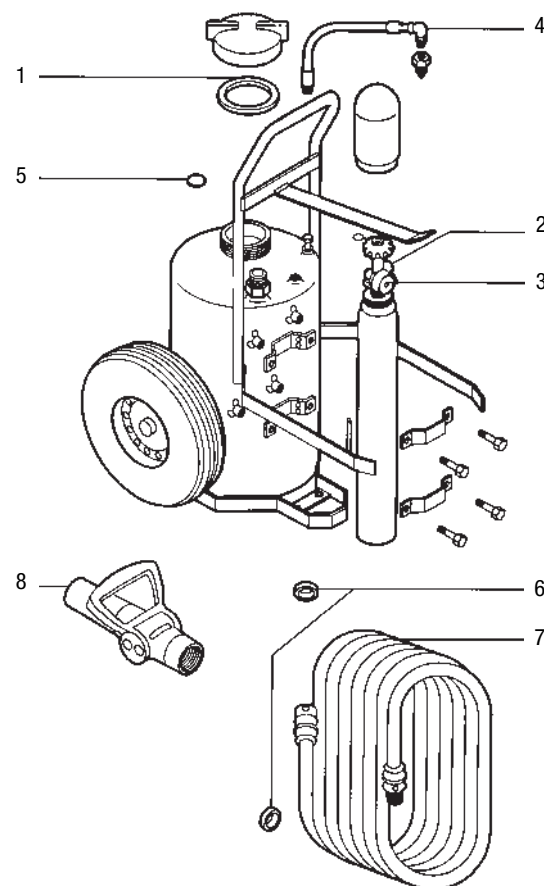
FIG.	PART#	DESCRIPTION
1	LSP	Pull Pin, Stainless Steel
2	A532	Chain (Nylon) for Ring Pin
3	TS	Tamper Seal
4	A9840	Lever & Rivet
5	A1563	Lever Rivet Only, Amerex Type
6	G240	Gauge - 240 PSI
7	A9020	Handle & Rivets, All Models
8	RV5	Handle Rivet Only, All Models (OEM# A1564)
9	OR215	Collar O-Ring (OEM# A5240)
10	A6093	Valve Stem Assembly
11	A5243	Valve Stem O-Ring
12	A383	Spring
13	A1667	Syphon Tube 20 lb
14	A14787	Hose & Horn Assembly (.166) 564 (Oct. 1999 and Later) - Male Coupling
14	A14786	Hose & Horn Assembly (.157) 566 (Oct. 1999 and Later) - Male Coupling
14	A14789	Hose & Horn Assembly (.312) 567, 568, 569 (Oct. 1999 and Later) - Male Coupling
14	A14948	Hose & Horn Assembly - 591, 591X
N/S	A9492	Recharge Adapter
N/S	HTAA1	Hydrostatic Test Adapter



EXTINGUISHER PICTOGRAM - AMEREX WHEELED CYLINDER OPERATED DRY CHEMICAL

450 452 468 470 472
 451 467 469 471

FIG.	PART#	DESCRIPTION
1	A2272W	Gasket, Cap
2	N100	Nitrogen Valve with Gauge, Handwheel Valve
2	N200QR	Nitrogen Valve with Gauge & Quick Release
3	G3000	Gauge - 3000 PSI
4	A2234W	Nitrogen Hose Assembly - 467, 468, 469, 470, 471, 472
4	A3818W	Nitrogen Hose Assembly - 450, 451, 452
5	A7411W	Moisture Seal
6	CEHG	Gasket, Hose and Nozzle (OEM# A3877)
7	A3501W	Hose Assembly, 50'
8	A6717W	Nozzle Assembly - 450, 451, 452
8	A7574W	Nozzle Assembly - 467, 468, 469, 470, 471, 472



ACCESSORIES

FIG.	PART#	DESCRIPTION
N/S	A4892	Hydrotest Test Adapter, Cylinder
N/S	A5720	Hydrotest Test Adapter, Hose
N/S	A2235W	Nitrogen Pressure Regulator - 467, 468, 469, 470, 471, 472



WATER - W02 WET CHEMICAL - K01

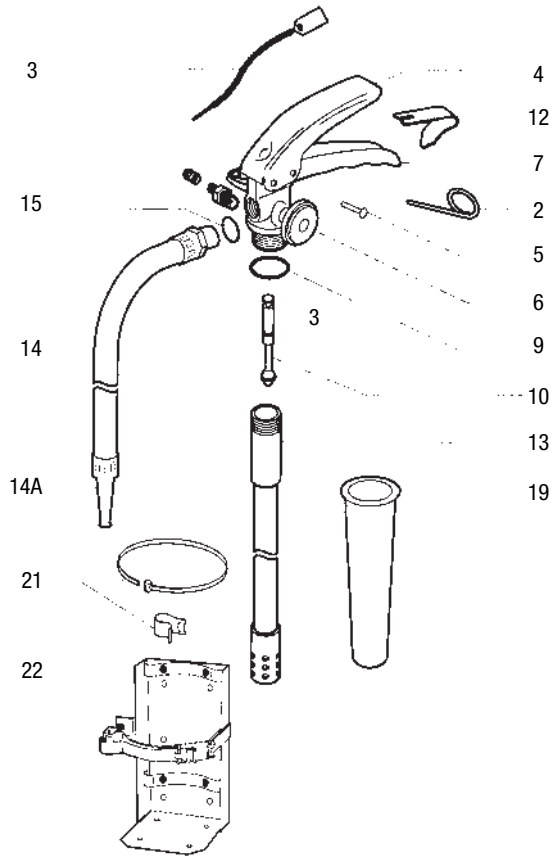


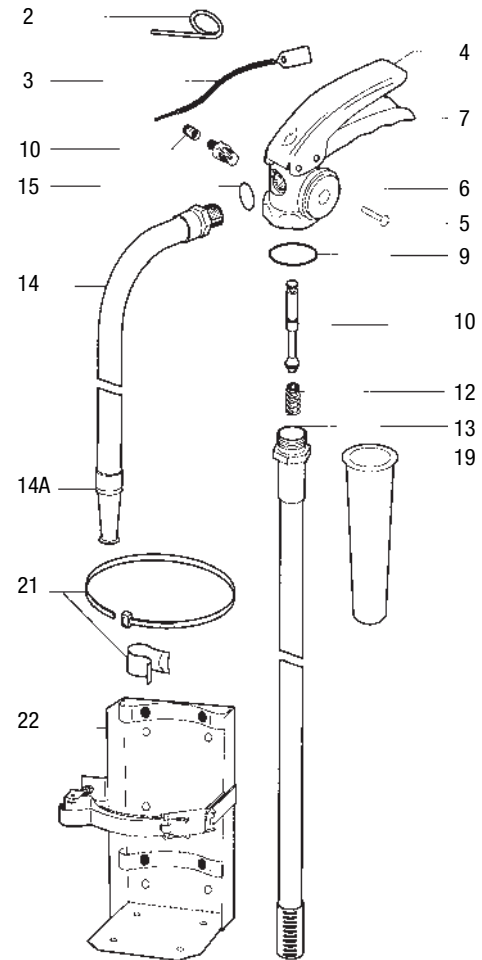
FIG.	PART#	DESCRIPTION	
2	AS430115	Pull Pin	
3	TS	Tamper Seal	
4	AS429163	Lever	Discontinued
5	AS429165	Rivet	
6	OFG100	Pressure Gauge - 100 PSI	
7	F429160	Handle (F10444) - Black	Discontinued
9	AS429537	Collar O-Ring	
10	F552144	Valve Stem Assembly (Replaces 429538)	Discontinued
12	AS429162	Leaf Spring	
13	AS430054	Pick Up Tube Assembly - K01	Discontinued
14	AS430055	Hose & Nozzle Assembly - K02	Discontinued
14A	AS426074	Nozzle Tip - K01	
15	AS429544	Hose O-Ring	
19	AS429541	Fill Tube	
N/S	430182AS	PRX Liquid for K-Guard - 6 Litre K01, K01-1	
N/S	423320AS	PRX Liquid for K-Guard - 5 Gal. K01, K01-1	
1D	AVA	Pressure Valve & Cap Assembly, W02	
N/S	CORE	Pressure Valve Core, W02	
21	UHS34/UHC	Universal Hose Strap/Clip	
22	VB8	Heavy-Duty Vehicle Bracket	
N/S	WH20	Wall Hanger	
N/S	RA11	Recharge Adapter - K01	
N/S	HTAF5	Hydrostatic Test Adapter	

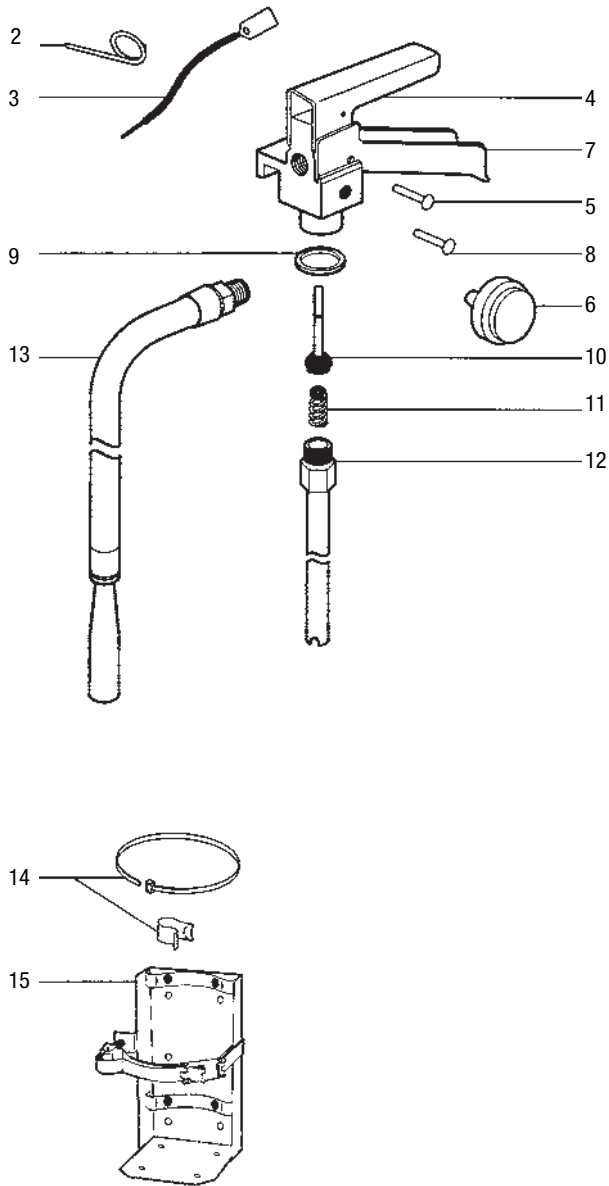
WATER - W02-1 WET CHEMICAL - K01-1, K01-2, K01-3



FIG.	PART#	DESCRIPTION
2	AS430115	Pull Pin
3	TS	Tamper Seal
4	AS430924	Lever
5	AS430250	Rivet
6	OFG100	Pressure Gauge - 100 PSI
7	AS430273	Handle (F11329) - Steel
9	AS56909	Collar O-Ring
10	AS429099	Valve Stem Assembly
12	AS430004	Spring
13	AS439713	Pick Up Tube Assembly - K01, K01-2, K01-3
13	AS430793	Pick Up Tube Assembly - W02-1
14	AS439495	Hose & Nozzle Assembly - K01-1, K01-2
14	AS429543	Hose & Nozzle Assembly - W02-1
14A	AS426074	Nozzle Tip - K01-1, K01-2
15	AS429544	Hose O-Ring
19	AS429541	Fill Tube
N/S	AS430274	Collar Nut
N/S	79372AS	3 Gal. of Ansulex Chemical, K01-2
N/S	430182AS	PRX Liquid for K-Guard - 6 Litre K01, K01-1
N/S	423320AS	PRX Liquid for K-Guard - 5 Gal. K01, K01-1
1D	AVA	Pressure Valve & Cap Assembly, W02-1
N/S	CORE	Pressure Valve Core, Pkg/50
21	UHS34/UHC	Universal Hose Strap/Clip
22	VB8	Heavy-Duty Vehicle Bracket
N/S	WH1	Wall Hanger
N/S	RA11	Recharge Adapter - K01-1, K01-2

Discontinued





DRY CHEMICAL – OLDER MODELS

SY-0513	SY-0623	SY-1013	SY-1033	SY-2023
SY-0514	SY-0624	SY-1014	SY-1034	SY-2024
SY-0613	SY-0633	SY-1023	SY-2013	SY-2033
SY-0614	SY-0634	SY-1024	SY-2014	SY-2034

HALON 1211

SY-0541	SY-0942	SY-1441	SY-1741
---------	---------	---------	---------

**CLEANGUARD (FE36) PARTS
ARE SPECIAL ORDER**

CA-0681	CA-1081	CA-1481
---------	---------	---------

FIG.	PART#	DESCRIPTION	
2	SPP	Pull Pin	
3	TS	Tamper Seal	
4	AS429163	Lever	Discontinued
5	RV78	Lever Rivet (17050) Ansul Type	
6	HG100	Gauge - 100 PSI - Halon - SY-0541	
6	G195	Gauge - 195 PSI - All Dry Chemical	
6	G195H	Gauge - 195 PSI - Halon - SY-1441, 1741	
6	AS429940	Gauge - (FE36) All Cleanguard OLD MODEL	Discontinued
7	AS78087	Handle	Discontinued
8	RV78	Handle Rivet (17050) Ansul Type	
9	QR40	Collar Quad Ring - All Dry Chemical (16222) Ansul Type	
9	QR43	Collar Quad Ring - All Halon (21882) Ansul Type	
10	ASVS4	Valve Stem Assembly (24489)	
11	AS29256	Spring	
12	AS31556	Syphon Tube - SY-1013, 1014, 1023, 1024, 1033, 1034, 1441	Discontinued
13	AS30613	Hose & Nozzle Assembly - SY-0613, 0614, 0633, 0634	Discontinued
13	AS30615	Hose & Nozzle Assembly - SY-1013, 1014, 1033, 1034	Discontinued
13	AS30617	Hose & Nozzle Assembly - SY-2013, 2014, 2033, 2034	Discontinued
13	AS30618	Hose & Nozzle Assembly - SY-2023, 2024	

ACCESSORIES

FIG.	PART#	DESCRIPTION
14	UHS34/UHC	Universal Hose Strap/Clip
15	VB6	Heavy Duty Vehicle Bracket - 9 - 14 lbs
15	VB7	Heavy Duty Vehicle Bracket - 17, 20 lbs.
N/S	AS16819	Wall Hanger - Up to 9 lbs
N/S	AS25298	Wall Hanger - 10, 14 lbs
N/S	AS30643	Wall Hanger - 17, 20 lbs
N/S	RA30	Recharge Adapter
N/S	HTAA1	Hydrostatic Test Adapter

DRY CHEMICAL – OLDER MODELS

SY-0212 SY-0215 SY-0236 SY-0516 SY-0521 SY-0635
 SY-0214 SY-0216 SY-0515 SY-0517 SY-0531

HALON 1211

SY-0241 SY-0242 SY-0243



FIG.	PART#	DESCRIPTION
2	SPP	Pull Pin
3	TS	Tamper Seal
4	AS68169	Lever
5	RV44	Lever Rivet (25719) Ansul Type
6	HG100	Gauge - 100 PSI - Halon - SY-0241, 0242, 0243
6	AS56776	Gauge - 195 PSI - All (Except SY-0241, 0242, 0243)
7	AS79119	Handle
8	RV47	Handle Rivet (25720) Ansul Type
9	QR41	Collar O-Ring, Replaces Quad Ring 25765 (79122)
10	ASVS5	Valve Stem Assembly, Replaces 21858 All Except SY-0516, 0517, 0521, 0531
10	AS429099	Valve Stem Assembly, SY-0516, (415202) 0517, 0521, 0531, 0241, 0242, 0243
11	AS25702	Spring - All Except SY-0516, 0517, 0521, 0531
11	F415565	Spring - SY-0516, 0517, 0521, 0531
13	AS27099	Nozzle - SY-0212, 0214, 0215, 0216
13	AS54444	Nozzle - SY-0515 without Hose
15	AS16047	O-Ring Nozzle - SY-0212, 0214, 0215, 0216, 0236, 05151

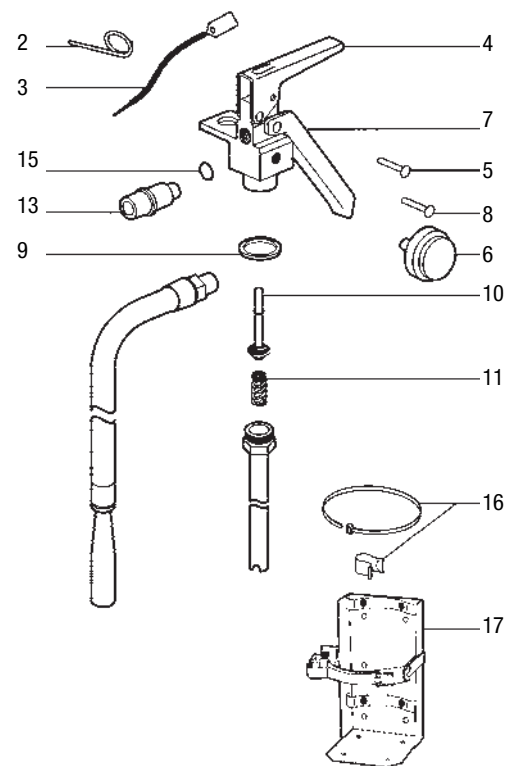
Discontinued

Discontinued

Discontinued

Discontinued

Discontinued



ACCESSORIES

FIG.	PART#	DESCRIPTION
16	UHS34/UHC	Universal Hose Strap/Clip
N/S	AS24610	Bracket Assembly - SY-0212, 0214, 0216, 0236
N/S	AS54160	Bracket Assembly - SY-0515
17	VB4	Heavy Duty Vehicle Bracket - SY-0516, 0517, 0521, 0531
N/S	RA12	Recharge Adapter - SY-0212, 0214, 0215, 0216, 0236, 0515
N/S	RA35	Recharge Adapter - SY-0516, 0517, 0521, 0531
N/S	HTAA3	Hydrostatic Test Adapter

Discontinued



CYLINDER OPERATED WHEELED EXTINGUISHERS - 150, 350 LBS.

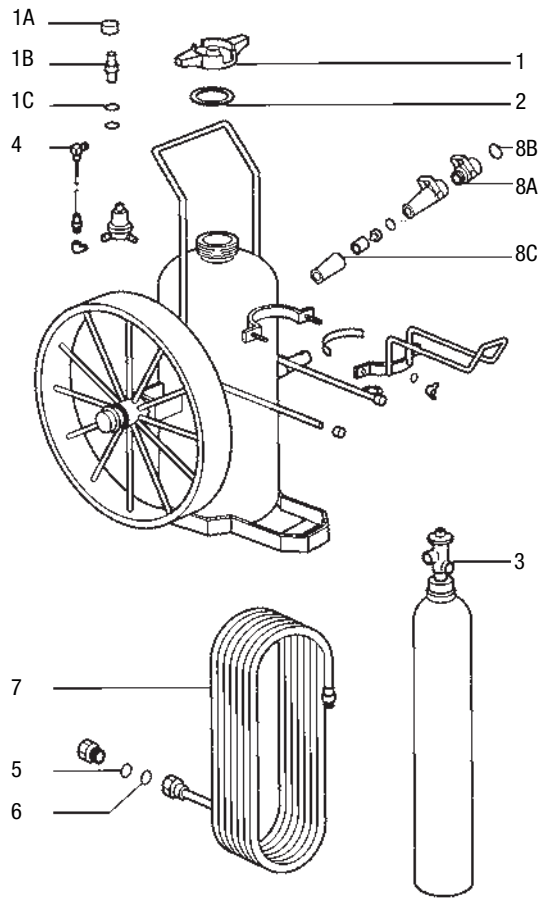


FIG.	PART#	DESCRIPTION
1	AN27335W	Fill Cap, Indicator - All Except MET-L-X, NAX
1A	AN17633	Indicator Cap
1B	AN27648	Indicator Stem
1C	AN17630	Quad Ring
2	G50W	Gasket (3461) Ansul Type
3	N100	Nitrogen Valve
4	AN423581W	Nitrogen Hose Assembly - (Valve to Regulator)
N/S	AN8750W	Low Pressure Hose - Regulator to Tank - 150 lb. - 350 (1969-1973)
5	AN14236W	Hose Visual Inspection Disc - 150 lbs
5	AN14237W	Hose Visual Inspection Disc - 350 lbs
6	CEHG	Gasket - 150 lbs (3877) Ansul Type
6	AN8105W	Gasket - 350 lbs
7	AN2272W	Hose 3/4" x 50' - 150 lbs (Except LT)
8A	AN8101W	Ball Valve - 150 lbs - Except MET-L-X, NAX
8B	AN11112W	Gasket, Valve to Hose - 150 lbs
8C	AN29507W	Body, Nozzle - All Except LR
N/S	AN419327	Regulator

**ANSUL - PYRO CHEM.
DRY CHEMICAL - NEW MODELS**

A02(S) A05 PK05 AA10S C10 PK20
 A02(S)VB AA05 C05 A10T AA20 C20
 C02VB A05VB A10H PK10

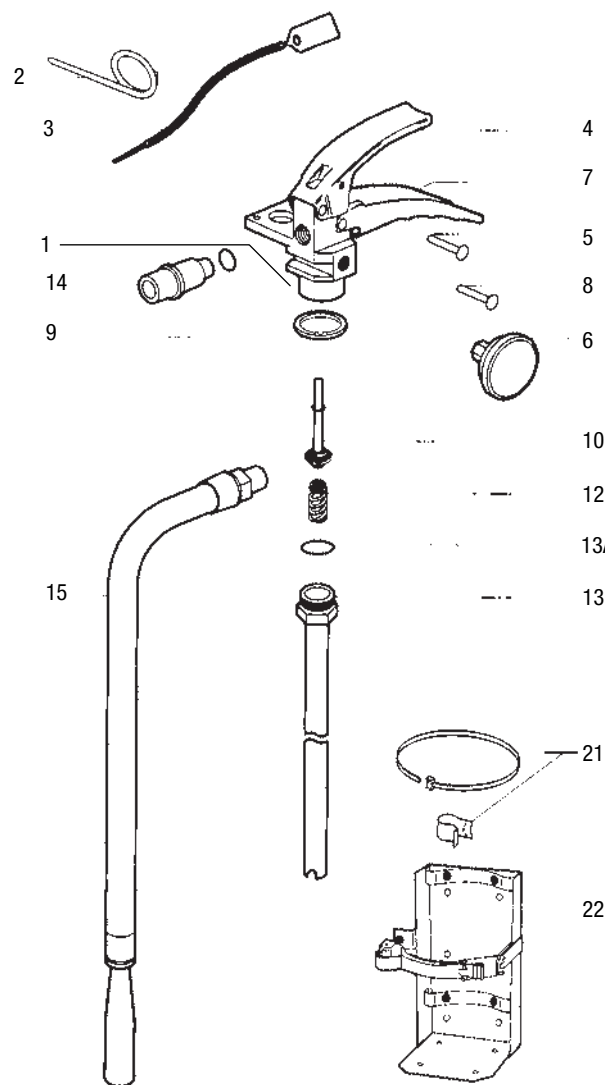
CLEANGUARD (FE36)

FE02VB FE05 FE09 FE13



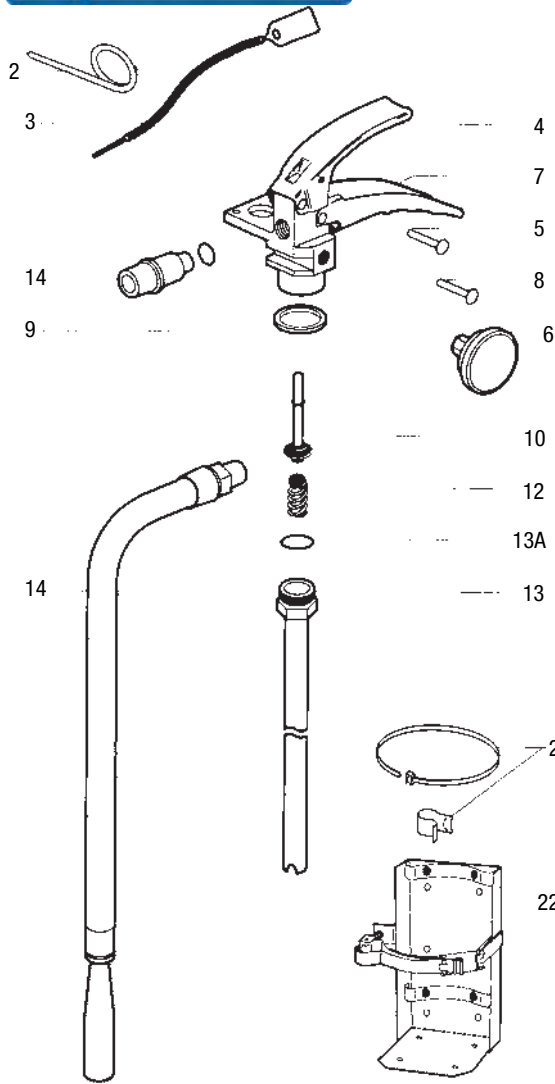
FIG.	PART#	DESCRIPTION
1	AS436890	Valve Assembly - All 2½ lb
1	AS429084	Valve Assembly - All 5 lb (Except Cleanguard)
1	AS429085	Valve Assembly - A10H, C10, PK10
1	AS429086	Valve Assembly - A10T
1	AS429087	Valve Assembly - All 20 lb
2	SPP	Pull Pin
3	TS	Tamper Seal
4	AS429096	Lever
5	AS428130	Lever Rivet
6	G195	195 lb Dry Chemical Gauge
6	AS56776	Gauge - 195 PSI - All Dry Chemical
6	AS426264	Gauge (FE36) - FE02VB, FE05
6	AS428940	Gauge (FE36) - FE09, FE13
7	AS429097	Handle
8	AS428130	Handle Rivet
9	AS428327	Collar Quad Ring - All D/C & Cleanguard
10	AS429099	Valve Stem Assembly D/C & Cleanguard
12	F415565	Spring
13	AS428795	Syphon Tube - All 2 1/2 lb. D/C & FE02VB
13	AS428796	Syphon Tube - All 5 lb. (Except Cleanguard)
13	AS428797	Syphon Tube - A10H, C10, PK10, FE09
13	AS428798	Syphon Tube - A10T & FE05
13	AS428799	Syphon Tube - All 20 lb & FE13
13A	AS76076	Syphon Tube - O'Ring
14	AS428269	Nozzle - A02, A02VB (not A02S)
14	AS442405	Nozzle - A02S, A02SVB
15	AS428729	Hose & Nozzle Assembly - AA05, AA05VB
15	AS428730	Hose & Nozzle Assembly - PK05
15	AS428728	Hose & Nozzle Assembly - A05, A05VB
15	AS428732	Hose & Nozzle Assembly - A10T, A10H, C10
15	AS436592	Hose & Nozzle Assembly - AA10S
15	AS428734	Hose & Nozzle Assembly - PK10
15	AS428736	Hose & Nozzle Assembly - AA20
15	AS428738	Hose & Nozzle Assembly - PK20
15	AS428740	Hose & Nozzle Assembly - C20
15	AS428742	Hose & Nozzle Assembly - FE05
15	AS428743	Hose & Nozzle Assembly - FE09, FE13
N/S	AS57744	Nozzle O'Ring - FE02VB

• SPECIAL ORDER



ACCESSORIES

FIG.	PART#	DESCRIPTION
21	UHS34/UHC	Universal Hose Strap/Clip
22	VB4	Heavy Duty Vehicle Bracket - 5 lb
22	VB5	Heavy Duty Vehicle Bracket 9 - 14 lb
22	VB7	Heavy Duty Vehicle Bracket 17 & 20 lb
N/S	WH5	Wall Hanger - Up to 9 lb
N/S	WH10	Wall Hanger - 10 & 15 lb
N/S	WH20	Wall Hanger - 17 & 20 lb
N/S	RA20	Recharge Adapter, All except A02S Models
N/S	AD38	Recharge Adapter for A02S/ A02SVB Models
N/S	HTA43	Hydrostatic Test Adapter



DRY CHEMICAL - NEW MODELS

A10I PK10I C10I A20I PK20I C20I

FIG.	PART#	DESCRIPTION
2	SPP	Pull Pin
3	TS	Tamper Seal
4	AS428428	Lever
5	AS428130	Lever Rivet
6	G195	Gauge - 195 PSI
7	AS428429	Handle
8	AS428130	Handle Rivet
9	AS428327	Collar O-Ring
10	AS428431	Valve Stem Assembly - Brass
12	F415565	Spring
13	AS428797	Syphon Tube - All 10 lb
13	AS428799	Syphon Tube - All 20 lb
13A	AS76076	Syphon Tube O'Ring
14	AS428733	Hose & Nozzle Assembly - A10I, C10I
14	AS428735	Hose & Nozzle Assembly - PK10I
14	AS428737	Hose & Nozzle Assembly - A20I
14	AS428739	Hose & Nozzle Assembly - PK20I

Discontinued

ACCESSORIES

FIG.	PART#	DESCRIPTION
21	UHS34/UHC	Universal Hose Strap/Clip
22	VB5	Heavy Duty Vehicle Bracket - All 10 lb
22	VB7	Heavy Duty Vehicle Bracket - All 20 lb
N/S	WH10	Wall Hanger - All 10 lb
N/S	WH20	Wall Hanger - All 20 lb
N/S	RA20	Recharge Adapter
N/S	HTA43	Hydrostatic Test Adapter

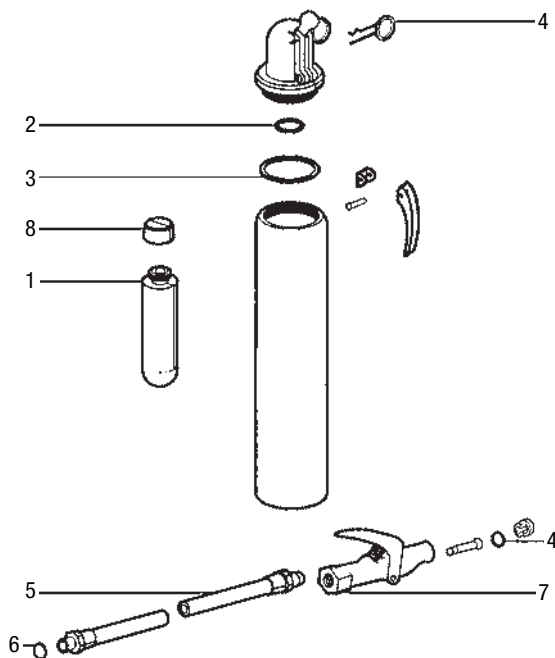
CARTRIDGE OPERATED DRY CHEMICAL

5 A-5 K-5 LR-5 LT-5 LT-A-5 LT-K-5

FIG.	PART#	DESCRIPTION
1	AN4523	Cartridge - CO2
1	AN7013	Cartridge - Nitrogen L.H.
1	AN6979TC	Cartridge - Nitrogen R.H.
2	G45	Gasket, Cartridge Receiver (181) Ansul Type
3	AN615	Gasket, Fill Cap
4	AN2332	Ring Pin
5	AN15799	Hose Assembly with Couplings - After 1967
6	OR014	O-Ring (6263) Ansul Type
7	AN6673	Nozzle Assembly - 5, LT-5
N/S	AN1662	Gasket, Nozzle Tip

ACCESSORIES

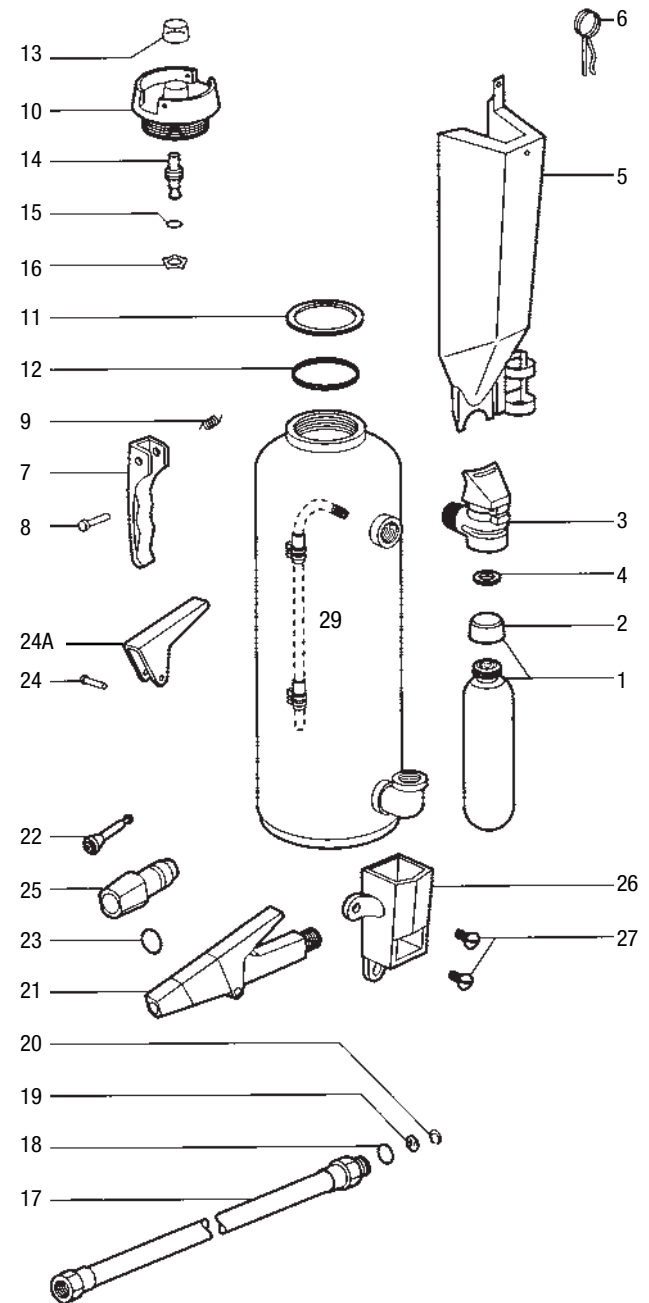
FIG.	PART#	DESCRIPTION
N/S	AN2128	Wall Hanger, 5 lb
N/S	AN79758	Bracket
8	LHSC	Cartridge Shipping Cap
8	RHSC	All Except LT
N/S	HTAAN5	Hydrostatic Test Adapter using Hose Assembly



**CARTRIDGES ARE T.C. STAMPED
(TRANSPORT CAN) AS REQUIRED
CARTRIDGE OPERATED
ALL 10 - 30 LBS. E AND G SERIES**



FIG.	PART#	DESCRIPTION
1	AN4616	10 lb CO2 Cartridge T.C.
1	AN4614TC	20 lb CO2 Cartridge T.C.
1	AN423433	30 lb CO2 Cartridge T.C.
1	AN13193TC	LT10 (Low Temp.) Nitrogen Cartridge (R.H.) T.C.
1	AN13177TC	LT10 (Low Temp.) Nitrogen Cartridge (L.H.) T.C.
1	423429AS	LT20 (Low Temp.) Nitrogen Cartridge (7032)(R.H.) T.C.
1	AN7012TC	LT20 (Low Temp.) Nitrogen Cartridge (L.H.) T.C.
1	423435AS	LT30 (Low Temp.) Nitrogen Cartridge (5373)(R.H.) T.C.
1	AN423437	LT30 (Low Temp.) Nitrogen Cartridge (L.H.) T.C.
2	LHSC	Cartridge Shipping Cap (L.H.)
2	RHSC	Cartridge Shipping Cap (R.H.)
3	AN3626	Cartridge Receiver Assembly L.H. Thread
3	AN1356	Cartridge Receiver Assembly R.H. Thread
4	G45	Gasket, Cartridge Receiver (181) Ansul Style
5	AN3652	Cartridge Guard Assembly 10 lb - CO2 (Metal)
5	AN6302	Cartridge Guard Assembly 20 lb - CO2 (Metal)
5	AN6287	Cartridge Guard Assembly 30 lb - CO2 (Metal)
5	AN12997	LT10 Cartridge Guard Assembly Nitrogen (Metal)
5	AN32025	LT20 Cartridge Guard Assembly Nitrogen (Metal)
5	AN6971	LT30 Cartridge Guard Assembly Nitrogen (Metal)
5	AN418023	CO2 Guard Assembly 10 lb (Plastic)
5	AN416346	CO2 Guard Assembly 20 lb (Plastic)
5	AN418025	CO2 Guard Assembly 30 lb (Plastic)
5	AN418024	LT 10 lb Guard Assembly 1(Plastic)
5	AN416524	LT 20 lb Guard Assembly (Plastic)
5	AN418026	LT 30 lb Guard Assembly (Plastic)
6	AN7095	Ring Pin
7	AN6169	Carrying Handle
8	RV91	Carrying Handle Rivet (1265) Ansul Style
9	AN2902	Carrying Handle Spring
10	AN17999	Fill Cap Assembly with Indicator
11	G48	Gasket, Fill Cap (6190) Ansul Type
12	QR39	Quad Ring, Fill Cap (6273) Ansul Type
13	AN17633	Cap, Plastic
14	AN27648	Stem, Indicator
15	AN17630	Quad Ring
16	AN1239	Retaining Ring
17	AN7083	30 lbs Hose Assembly
17	AN7091	20 lbs Hose Assembly
17	AN13005	10 lbs Hose Assembly
18	AN6263	Hose O-Ring - 10 lbs
18	AN6323	Hose O-Ring - 20 lbs
18	AN6324	Hose O-Ring - 30 lbs



CARTRIDGE OPERATED CONTINUED

FIG.	PART#	DESCRIPTION
19	AN415659	Hose Seal - 10 lbs G Series
19	AN415660	Hose Seal - 20 lbs E and G Series
19	AN415661	Hose Seal - 30 lbs G Series
20	AN415855	Retaining Ring - 10 lbs G Series, Pkg. of 50
20	AN415856	Retaining Ring - 20 lbs E and G Series, Pkg. of 50
20	AN415857	Retaining Ring - 30 lbs G Series, Pkg. of 50
21	AN14045	Nozzle Assembly - 30 lbs Regular Dry Chemical
21	AN14551	Nozzle Assembly - 20 lbs Regular Dry Chemical
21	AN30778	Nozzle Assembly - 30 lbs ABC, PK
21	AN30789	Nozzle Assembly - 20 lbs ABC, PK
21	AN31407	Nozzle Assembly - 10 lbs ABC
22	AN56117	Nozzle Plunger
23	AN1230	O-Ring, Nozzle without O-Ring Groove
23	AN3469	O-Ring, Nozzle
24	AN3621	Rivet, Nozzle Handle
24A	AN6580	Handle Nozzle Assembly (Old #AN6266)
25	AN17908	Tip, Nozzle Assembly - 20 lbs Regular Dry Chemical
25	AN17932	Tip, Nozzle Assembly - 30 lbs Regular Dry Chemical
25	AN30790	Tip, Nozzle Assembly - 20 lbs ABC, PK
25	AN30791	Tip, Nozzle Assembly - 30 lbs ABC, PK
26	AN74206	Nozzle Holder Assembly - E Series
27	AN14908	Nozzle Platform Screw - E Series (2 required)
N/S	AN3651	Wall Hanger Hook, 10, 20, 30 lbs

Discontinued

Carbon Dioxide - W/Flag Valve Accessories (Page 215)

FIG.	PART#	DESCRIPTION
N/S	RS15	Band - 10, 15 lb Alum. Cylinder
N/S	RS20	Band - 20 lb Alum. Cylinder
N/S	FSET	Hardware for RS10-15-20
N/S	ARD	Aluminum 10-20 lb Rapid Discharge Horn Band
N/S	SET2	Hardware Set, All 10, 15, 20 lb
N/S	BL209	Replacement Nameplate - 5 lb (non UL) All 5 lb
N/S	BL210	Replacement Nameplate - 10-20 lb (non UL) All 10, 15, 20 lb
N/S	WH5	Wall Hanger, All 5 lb
N/S	WH10	Wall Hanger, All 10, 15 lb
N/S	WH20	Wall Hanger, All 20 lb

PARTS & ACCESSORIES

FIG.	PART#	DESCRIPTION
29	AN6313	10 lb Gas Tube
29	AN6317	20 lb Gas Tube
29	AN6320	30 lb Gas Tube
N/S	AN13005	Hose Assembly (10 lb)
N/S	AN7091	Hose Assembly (20 lb)
N/S	AN7083	Hose Assembly (30 lb)
30	AN14228	Vehicle Bracket - 10 lb (NOT SHOWN)
30	AN14091	Vehicle Bracket - 20 lb (NOT SHOWN)
30	AN14098	Vehicle Bracket - 30 lb (NOT SHOWN)
N/S	HTAAN10	Hydrostatic Test Adapter Using Hose Assembly
N/S	HTA12D	Hydrostatic Test Adapter Cylinder Only
N/S	AN416374	Maintenance Nameplate for 20 lb Units
N/S	AN416375	Maintenance Nameplate for 30 lb Units
N/S	AN69566	Operating Label Nameplate (All PK)
N/S	AN69567	Operating Label Nameplate (ABC 30 lb)

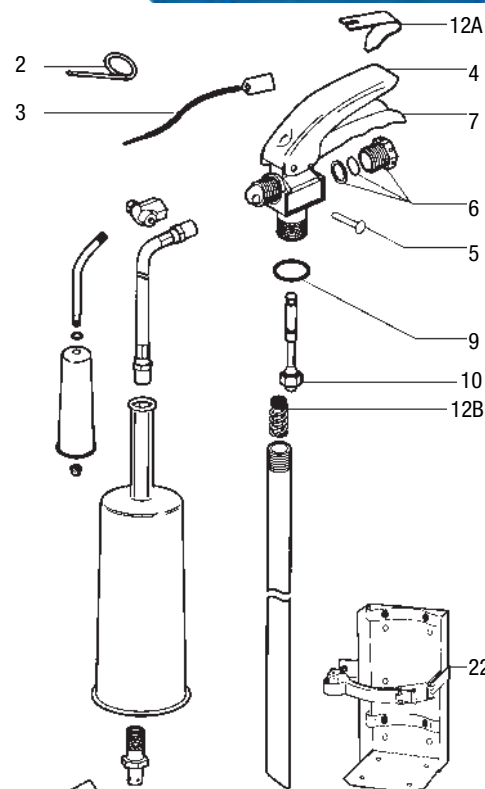
Discontinued

CARBON DIOXIDE - W/FLAG VALVE

CD05 CD10 CD15A CD20A CD05A-1 CD10A-1 CD15A-1 CD20A-1
 CD05A CD15 CD20 CD05-1 CD10-1 CD15-1 CD20-1

FIG.	PART#	DESCRIPTION
2	SPP	Pull Pin, Stainless Steel
3	TS	Tamper Seal
4	AS429163	Lever (Black)
4	AS432775	Lever (Chrome)
5	AS429165	Lever Rivet
6	F429515	Safety Disc, Gasket & Nut Assy.
7	F429160	Handle (Black)
7	AS432776	Handle (Chrome)
9	AS429170	Collar O-Ring
10	AS429154	Valve Stem Assembly
12A	AS429162	Spring (Leaf Style)
12B	F415565	Spring (Coil Style)

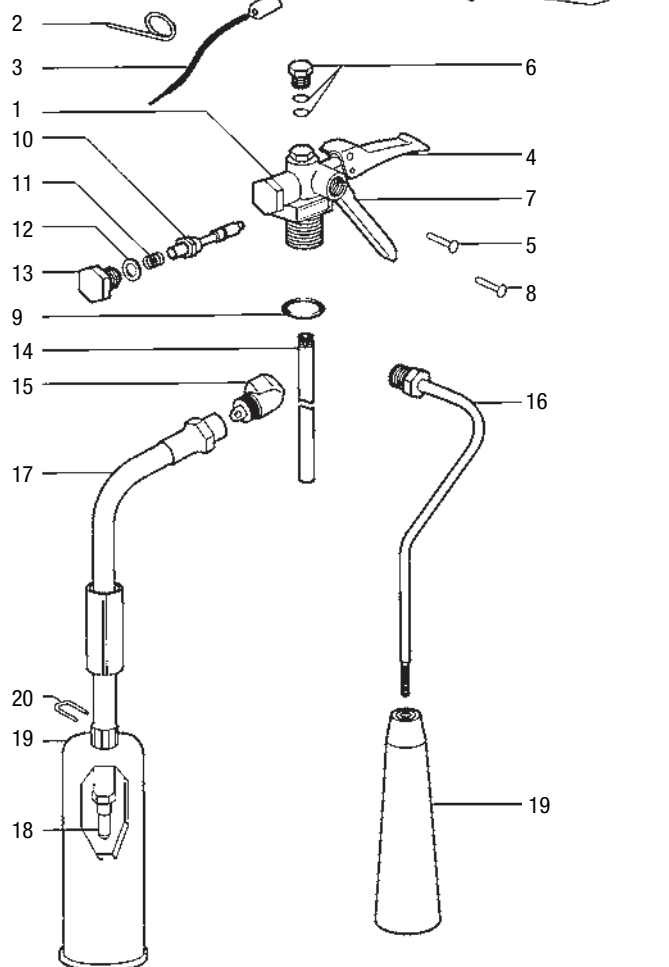
Discontinued
Discontinued
Discontinued
Discontinued



CARBON DIOXIDE - WITH R.S. VALVE (PSH-1)

SY-0571 SY-1071 SY-1571 SY-2071
 SY-0572 SY-1072 SY-1572 SY-2072

FIG.	PART#	DESCRIPTION
1	PSH10AL	Valve Assembly - SY-1072, 1572, 2072 (Aluminum Cylinder) (79438)
2	SPP	Pull Pin, Stainless Steel
3	TS	Tamper Seal
4	RS0102	Lever
5	RV63	Rivet, Lever (418689) Ansul Type
6	RS5	Ansul & RS CO2 Disc, Washer & Nut Assembly, Torque 40 ft-lb
7	RS0104	Handle
8	RV81	Rivet, Handle (418690) Ansul Type
9	OR216A	Collar O-Ring
10	RS0108	Valve Stem Assembly (79806)
11	RS0109	Spring (418683)
12	RS0110	Washer
13	RS0111	Nut Plug (418684)
14	5SYP	Syphon Tube - All 5 lbs
14	10SYP	Syphon Tube - SY-1071, SY-1072 10 lbs
14	15SYP	Syphon Tube - All 15-20 lbs (AN79478 Type)
15	ELB25	Elbow - All 10, 15, 20 lbs (AN79352 Type)
16	SW50	Discharge Tube Assembly - All 5 lbs (AN73861 Type)
17	361	Hose Assembly - All 10, 15, 20 lbs (AN77628 Type)
18	RDD	Nozzle - All 10, 15, 20 lbs. (AN79474 Type)
19	CH5	Horn - All 5 lbs. (AN79350 Type)
19	RDH10	Horn with Handle - All 10, 15 lbs. (AN77892 Type)
19	RDH15	Horn with Handle - All 20 lbs. (AN77893 Type)
20	RDC	U-Pin - All 10, 15, 20 lbs. (AN77894 Type)





**BADGER ADVANTAGE MODELS
DRY CHEMICAL 2½ - 20LB. MODELS**

MODELS ADV250 ADV4-1* ADV550 ADV10 ADV20

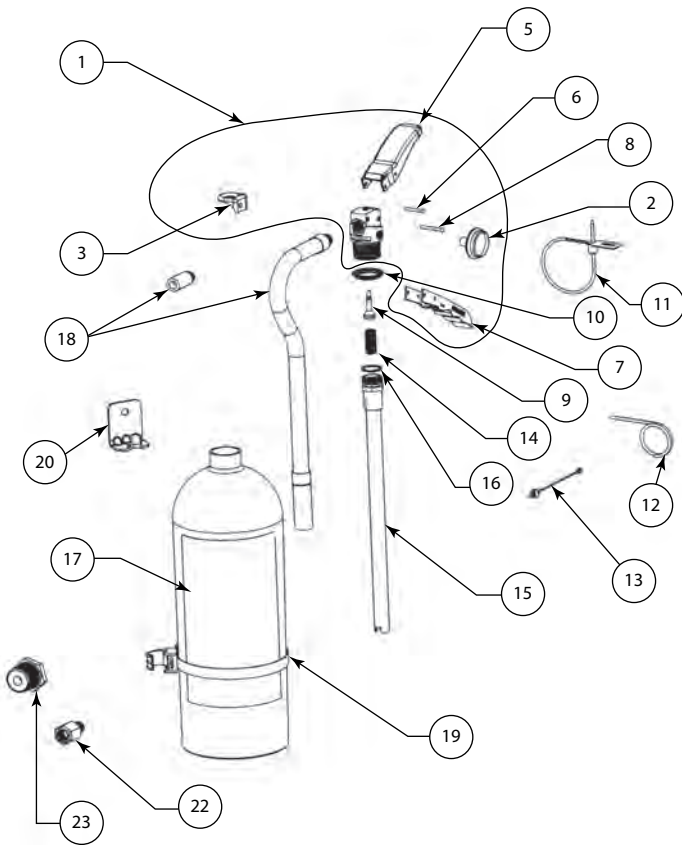


FIG.	PART#	DESCRIPTION
1	B21008376	Valve Assembly 2½ & 4 lb
1	B21008377	Valve Assembly 5½, 10 & 20 lb
2	G100	Pressure Gauge 2½ & 4 lb
2	G195	Presser Gauge 5½, 10 & 20 lb
3	B8516	Hanger Loop
5	B21007875	Operating Lever 2½, 4, 5½, 10 & 20 lb
6	P320751	Lever Rivet
7	B21007873	Carrying Handle 2½, 4, 5½ lb
7	B21007874	Carrying Handle 10 & 20 lb
8	P320750	Handle Rivet
9	P440068K	Valve Stem including O-Ring 2½, 4, 5½, 10 & 20 lb
10	B340035	Neck Seal - 2½, 4, 5½, 10 & 20 lb
11	TS	Tamper Seal
12	SPP	Pull Pin
13	B23535	Pull Pin Tether
14	B322063	Spring - 2½, 4, 5½, 10 & 20 lb
15	B21007861	Syphon Tube - 2½ lb
15	B21008373	Syphon Tube - 4 lb (ADV4-1*)
15	B21007862	Syphon Tube - 5½ lb (ADV4*, ADV550)
15	B21007863	Syphon Tube - 10 lb (ADV10)
15	B21007864	Syphon Tube - 20 lb (ADV20)
16	P320167K	Syphon Tube - O-Ring
18	B21005805	Discharge Nozzle - 2½ lb
18	B440310	Discharge Hose (ADV4)
18	B21009124	Discharge Hose (ADV4-1)
18	B21006335	Discharge Hose - 5½ lb
18	B21007908	Discharge Hose - 10 lb
18	B21006338	Discharge Hose - 20 lb
20	B1141	Wall Hook - 2½ lb
20	WH5	Wall Hook - 4, 5½, 10 lb
20	B14260	Wall Hook - 20 lb
22	RA20	Charging Adapter
23	B21007876	Hydro-Test Adapter (requires OR212)

* Badger 4.0 lb extinguisher. Current production model is the ADV4-1. This uses the shorter 4 lb, 143 cu inch cylinder introduced in 2012. First production run (ADV4) used the tall 5 lb, 160 cu inch cylinder. This model has been discontinued.

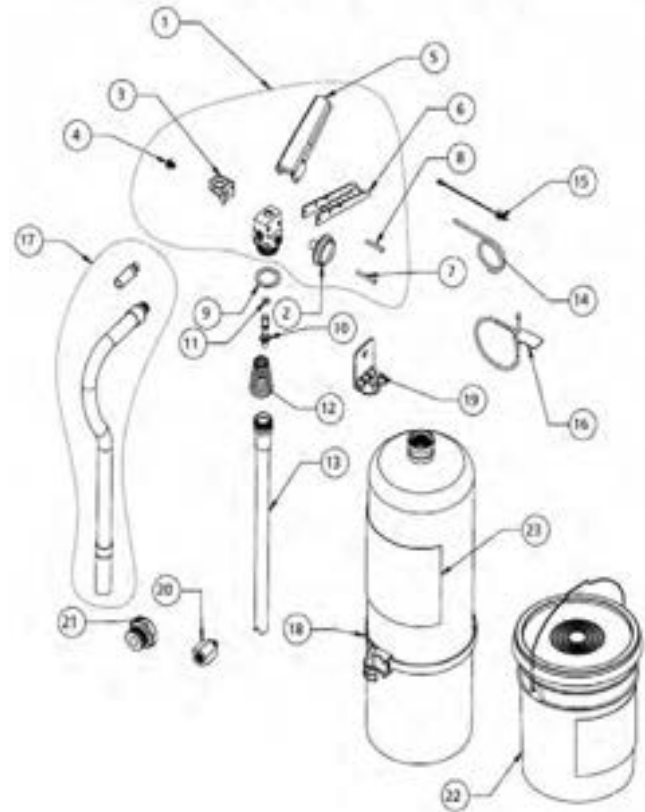
BADGER EXTRA PARTS PRICING
DRY CHEMICAL UNITS 2 1/2, 2 3/4, 5, 10, & 20 LB



SMALL BRASS VALVE MOVELS:	B250M	B275BC	B5M1	B5BC	B10BC
	B250P	B5M	B5P	B10M	B10P
LARGE BRASS VALVE MOVELS:	B10M-1	B20P	B10M-1-HF	B20M-HF	
	B20M	B20BC	B10P-1-HF	B20P-HF	

FIG.	PART#	DESCRIPTION
1	B21008380	Small Brass Valve Assembly (250, 275, 5 & 10 lb models)
1	B21008381	Large Brass Valve Assembly (10M-1 & 20 lb models)
2	G195	Pressure guage - 195 PSI
3	B21389	Hanger Loop
5	B23351	Operating lever (small valve models)
5	B16438	Operating lever (large valve models)
6	B23353	Carrying handle (small valve models)
6	B16437	Carrying handle (large valve models)
7	B23352	Operating lever rivet (small valve models)
7	B16633	Operating lever rivet (large valve models)
8	B23354	Carrying handle rivet small valves (2 required)
8	RV30	Carrying handle rivet large valves (2 required)
9	B20745	O-ring valve collar (small valve models)
9	B20746	O-ring valve collar (large valve models)
10	B23389	Valve stem (small valve models)
10	B23795	Valve stem (large valve models)
12	B19393	Spring (small valve models)
12	B7630	Spring (large valve models)
13	B23400	Siphon tube (2.5, 2.75 & 5 lb models)
13	B23379	Siphon tube (10MB-8H, 10PB-6H, 10RB-7H)
13	B23378	Siphon tube (10M-1)
13	B23377	Siphon tube (20 lb models)
14	SPP	Pull Pin
16	TS	Tamper Seal
17	B23387	Discharge nozzle (B250M) 0.136 orifice
17	B23487	Discharge nozzle (B250P) 0.1285 orifice
17	B23473	Discharge nozzle (B275BC) 0.125 orifice
17	B23393	Discharge hose assembly (B5M, B5M1 Models) 0.159 orifice
17	B23478	Discharge hose assembly (B5BC Model) 0.169 orifice
17	B23399	Discharge hose assembly (B10M Model) 0.180 orifice
17	B22601	Discharge hose assembly (B10M1 Model) 0.177 orifice
17	B23784	Discharge hose assembly (B10BC, B10P Models) 0.177 orifice
17	B21407	Discharge hose assembly (B20M Model) 0.209 orifice
17	B22853	Discharge hose assembly (B20BC Model) 0.185 orifice
17	B22711	Discharge hose assembly (B20P Model) 0.189 orifice
17	B21006168	Discharge hose assembly (All HF - High Flow Models)

BADGER EXTRA STORED PRESSURE DRY CHEMICAL PORTABLE EXTINGUISHER DIAGRAM (BRASS VALVE)



ACCESSORIES

FIG.	PART#	DESCRIPTION
18	UHS34	Hose Strap - All Models
18	UHC	Clip for Hose Strap
19	WH5	Wall Hook - All 2 1/2 & 5 lb models
19	WH10	Wall Hook - All 10 lb models
19	WH20	Wall Hook - All 20 lb models
20	R04646	Recharge Adapter (small valve models)
20	B4795	Recharge Adapter (large valve models)
21	HTA45	Cylinder hydro test adapter (small valve models)
21	HTA44	Cylinder hydro test adapter (large valve models)

Discontinued



DRY CHEMICAL

275RB-1 5RB-4H 5MB-5H 5MB-7H 6MB-4H 10MB-4H
 250MB-1 5MB-4H 5MB-6H 5MB-8H 10MB-3H 10MB-8H

HALON 1211

2.5-1211B 5-1211B 9-1211B-S 9-1211B-T

HALOTRON 1

2.5 HB 5 HB

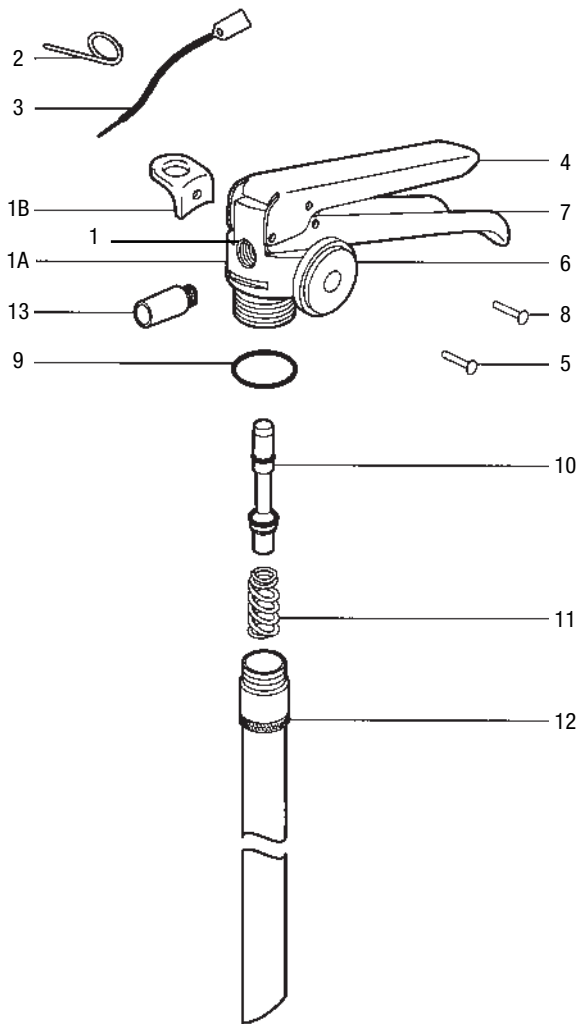


FIG.	PART#	DESCRIPTION
1	B19824	Valve Assembly 5MB-5H, 5MB-6H, 5MB-7H, 5MB-8H
1A	B19520	Valve Body
1B	B8516	Hanger Loop - All Except 275RB-1, 250MB-1, 2.5-1211B
2	SPP	Pull Pin
3	TS	Tamper Seal
4	B18363	Lever
5	B18404	Lever Rivet
6	G195	Gauge-195 PSI - All Dry Chemical
6	HG125	Gauge-125 PSI (Halon) - 2.5-1211B, 5-1211B
6	G195H	Gauge-195 PSI (Halon) - 9-1211B-S, 9-1211B-T
6	G100T	Gauge-100 PSI - All Halotron I
7	B18361	Handle
8	RV30	Handle Rivet (16517) Badger Type
9	OR212	Collar O-Ring (20745) Badger Type All Dry Chemical & Halon
9	B29074	Collar O-Ring- All Halotron I
10	B19010	Valve Stem - All Dry Chemical, All Halon
10	B23086	Valve Stem - All Halotron I
11	B19393	Spring - 5MB-5H, 5MB-6H, 5MB-7H, 5MB-8H, 6MB-4H, 10MB-3H
11	B1023	Spring - 275 RB-1, 250 MB-1, 5RB-4H, 5MB-4H All Halon and Halotron 1
12	B19825	Syphon Tube - 5MB-5H, 5MB-6H, 5MB-7H, 5MB-8H
13	B19455	Nozzle - 275RB, 275RB-1
13	B14816	Nozzle - 250 MB-1
14	B19547	Hose & Nozzle Assembly - 5RB-4H, 6MB-4H
14	B19548	Hose & Nozzle Assembly - 5MB-4H, 5MB-5H
14	B21028	Hose & Nozzle Assembly - 5MB-6H, 5MB-8H

Discontinued

Discontinued

Discontinued

Discontinued

HALOTRON PARTS ARE SPECIAL ORDER

ACCESSORIES

FIG.	PART#	DESCRIPTION
N/S	RA16	Recharge Adapter
N/S	HTA45	Hydrostatic Test Adapter

DRY CHEMICAL

5RB-2 10MB-2H 10PB-2H 20RB-1H 20MB-2H
 6MB-1 10RB-2H 20MB-1H 20PB-1H

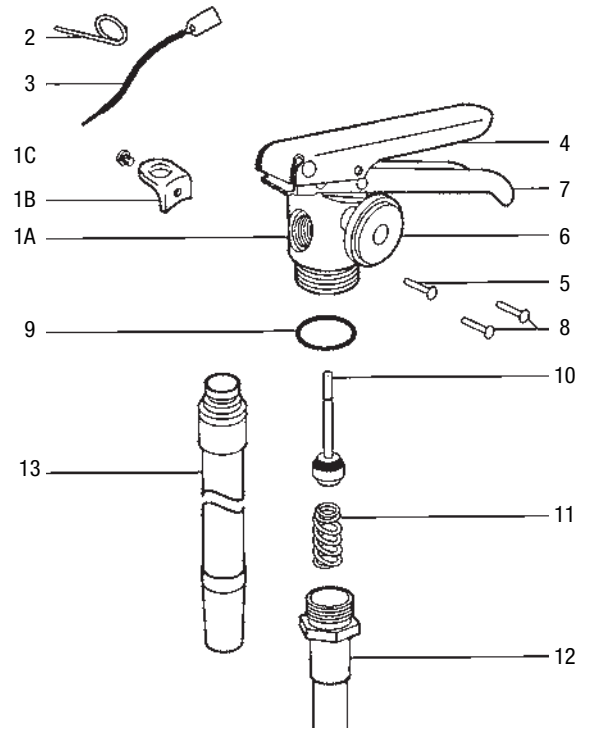
HALON 1211

13-1211B-S 13-1211B-T 17-1211B 20-1211B



FIG.	PART#	DESCRIPTION
1B	B8516	Hanger Loop
1C	B19622	Hanger Loop Screw
2	SPP	Pull Pin
3	TS	Tamper Seal
4	B16515	Lever
5	B16518	Lever Rivet
6	G195	Gauge - 195 PSI - Dry Chemical
6	G195H	Gauge - 195 PSI - Halon
7	B16513	Handle
8	RV30	Handle Rivet (16517) Badger Type
9	OR215	Collar O-Ring (20746) Badger Type
10	B23795	Valve Stem Assembly - Dry Chemical
10	B19010	Valve Stem - Halon
11	B7630	Spring
13	B20580	Hose & Nozzle Assembly - 20MB-1H

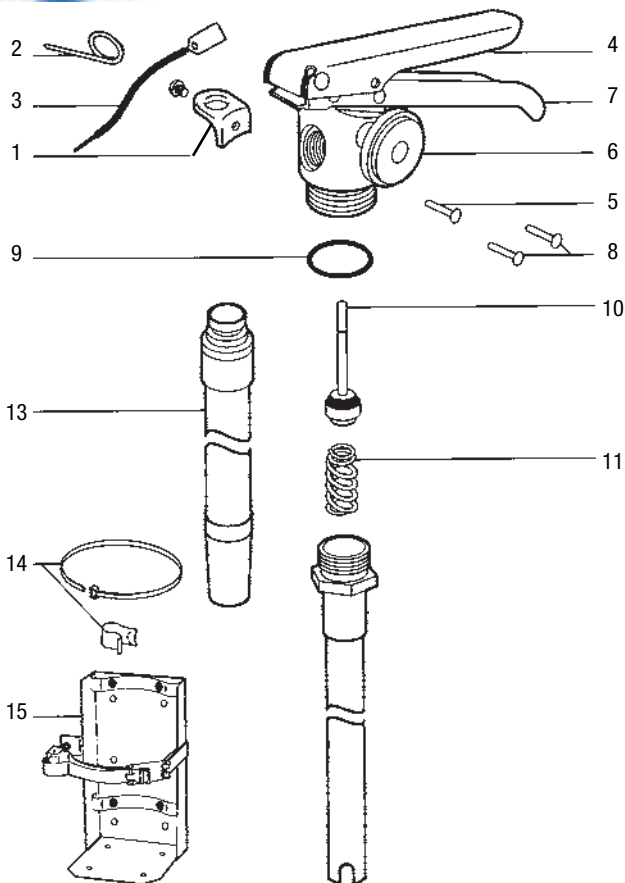
Discontinued



ACCESSORIES

FIG.	PART#	DESCRIPTION
N/S	RA11	Recharge Adapter
N/S	HTA44	Hydrostatic Test Adapter

HALOTRON PARTS ARE SPECIAL ORDER



DRY CHEMICAL

10MB-5H 10MB-9H 10RB-3H 20MB-3H 20RB-2H

HALOTRON 1

11 HB 15.5 HB

FIG.	PART#	DESCRIPTION
1	B21389	Hanger Loop
2	SPP	Pull Pin, Stainless Steel
3	TS	Tamper Seal
4	B16438	Lever
5	B16633	Lever Rivet
6	G195	Gauge - 195 PSI
6	G125T	Gauge - 125 PSI - All Halotron I
7	B16437	Handle
8	RV30	Handle Rivet (4095) Badger Type
9	OR215	Collar O-Ring (20746) Badger Type All Dry Chemical
10	B23795	Valve Stem Assembly
10	B23086	Valve Stem Assembly - All Halotron I
11	B7630	Spring
13	B21407	Hose & Nozzle Assembly - 20MB-3H
13	B22601	Hose & Nozzle Assembly - 10MB-9H

Discontinued

ACCESSORIES

FIG.	PART#	DESCRIPTION
14	UHS34/UHC	Universal Hose Strap/Clip
N/S	WH10	Wall Hanger - 10 lbs
N/S	WH20	Wall Hanger - 20 lbs
15	VB5	Heavy Duty Vehicle Bracket - 10 lbs
15	VB8	Heavy Duty Vehicle Bracket - 20 lbs
N/S	RA11	Recharge Adapter
N/S	HTA44	Hydrostatic Test Adapter

DRY CHEMICAL

P200RA P275RA P250MA 2½ LB

HALON

P1.25-1211A 2.5-1211A

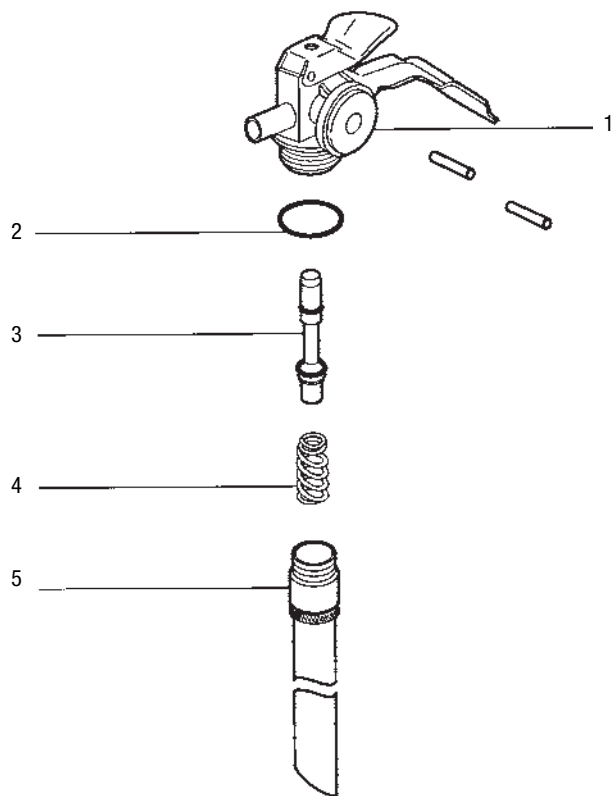


FIG.	PART#	DESCRIPTION
1	G100	Gauge - 100 PSI - P200RA
1	G195	Gauge - 195 PSI - P275RA, P250MA
1	HG100	Gauge - 100 PSI - Halon - P1.25-1211A
2	OR212	Collar O-Ring (20745) Badger Type
3	B19010	Valve Stem Assembly - Dry Chemical, Halon
4	B1023	Spring

ACCESSORIES

FIG.	PART#	DESCRIPTION
N/S	RA16	Recharge Adapter - P275RA, 250MA, P25-1211A
N/S	RA10	Recharge Adapter - P200RA, P1.25-1211A
N/S	HTA45	Hydrostatic Test Adapter

Discontinued

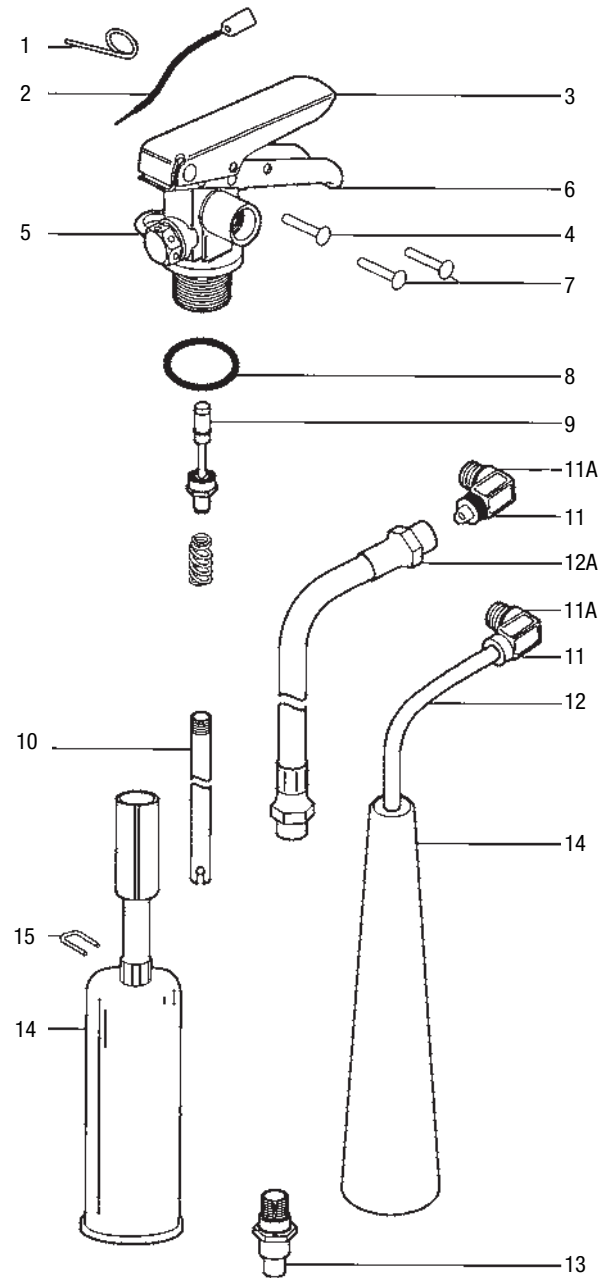
**CANADIAN MODEL BADGER-PYRENE
PYRENE/BADGER - CO2 UNITS 5, 10, 15 & 20 LB**

B5V-C B10V-C B15V-C B20V-C



FIG.	PART#	DESCRIPTION
	B23304	Valve Assembly
1	SPP	Pull Pin
N/S	B23603	Pull Pin Rubber Tether
2	TS	Tamper Seal
3	B16438	Lever
4	B16633	Lever Rivet
5	B24643	Safety Disc, Washer & Nut Assembly
6	B16437	Handle
7	RV30	Handle Rivet
8	OR216A	Collar O'Ring
9	B20981	Valve Stem Assembly
16	B3523	Spring
10	5SYP	Syphon Tube B5V-C
10	10SYP	Syphon Tube B10V-C
10	15SYP	Syphon Tube - B20V-C
11	B21119	Elbow B5V-C (Includes O'Ring)
11	B21100	Elbow -B10V-C, B15V-C, B20V-C (incl. O'Ring)
11A	OR111	O'Ring, Elbow
12	SWT2	Discharge Tube -B5V-C
12A	361	Hose & Nozzle Assembly B10V-C, B15V-C, B20V-C
14	CH5D	Horn - B5V-C
14	RDH10	Horn with Handle B10V-C
14	RDH15	Horn with Handle B15V-C, B20V-C
15	RDC	U-Pin B10V-C, B15V-C, B20V-C
	WH5	Wall Hook - B5V-C
	WH10	Wall Hook - B10V-C, B15V-C
	WH20	Wall Hook - B20V-C

Discontinued





CARBON DIOXIDE

B5H-1 B10H-2 B15H-2 B20H-2

B5H-1A B10HA B15HA B20HA 5, 10, 15 & 20 LB

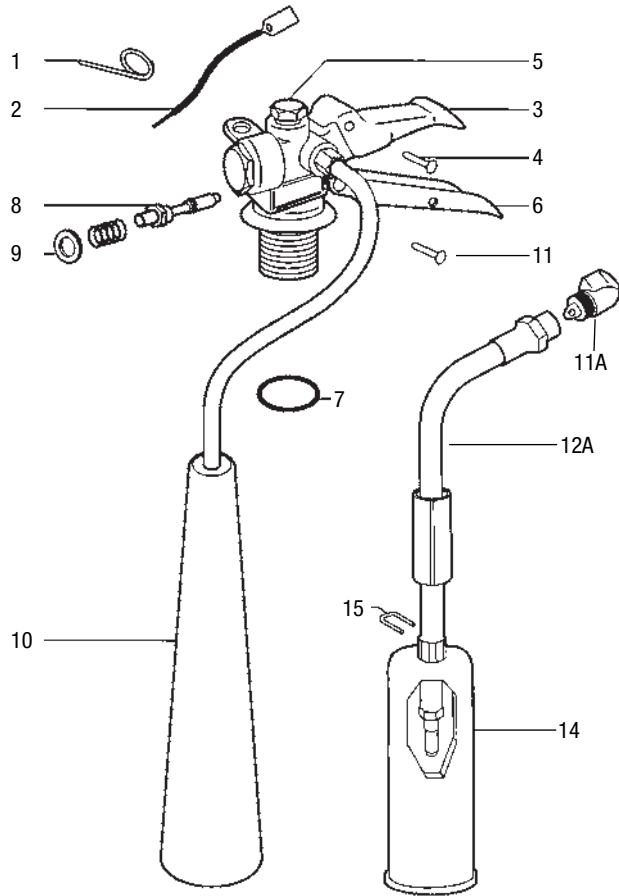


FIG.	PART#	DESCRIPTION
1	SPP	Pull Pin
2	TS	Tamper Seal
3	RS0102	Lever - Badger Type
4	RV63	Lever Rivet
5	B24643	Safety Disc, Washer & Nut Assembly
6	RS0104	Handle
7	OR216A	Collar O-Ring - B5H-1A, B10HA, B15HA, B20HA
8	RS0108	Valve Stem Assembly - Badger Type
9	RS0110	Retainer Washer (3524)
12A	361	Hose Assembly - All 10, 15, 20 lbs
13	RDD	Nozzle - All 15 & 20 lb
10	CH5D	Horn - 5 lb
14	RDH10	Horn with Handle - 10 lb
14	RDH15	Horn with Handle - 15 lb
15	RDC	Diffuser Clip for RDH CO2 Horn
11	RV81	Handle Rivet
11A	ELB25	Elbow
11A	ELB37	Elbow

**BADGER WET CHEMICAL (CLASS K)
AND PRESSURE WATER
WATER LOADED STREAM**

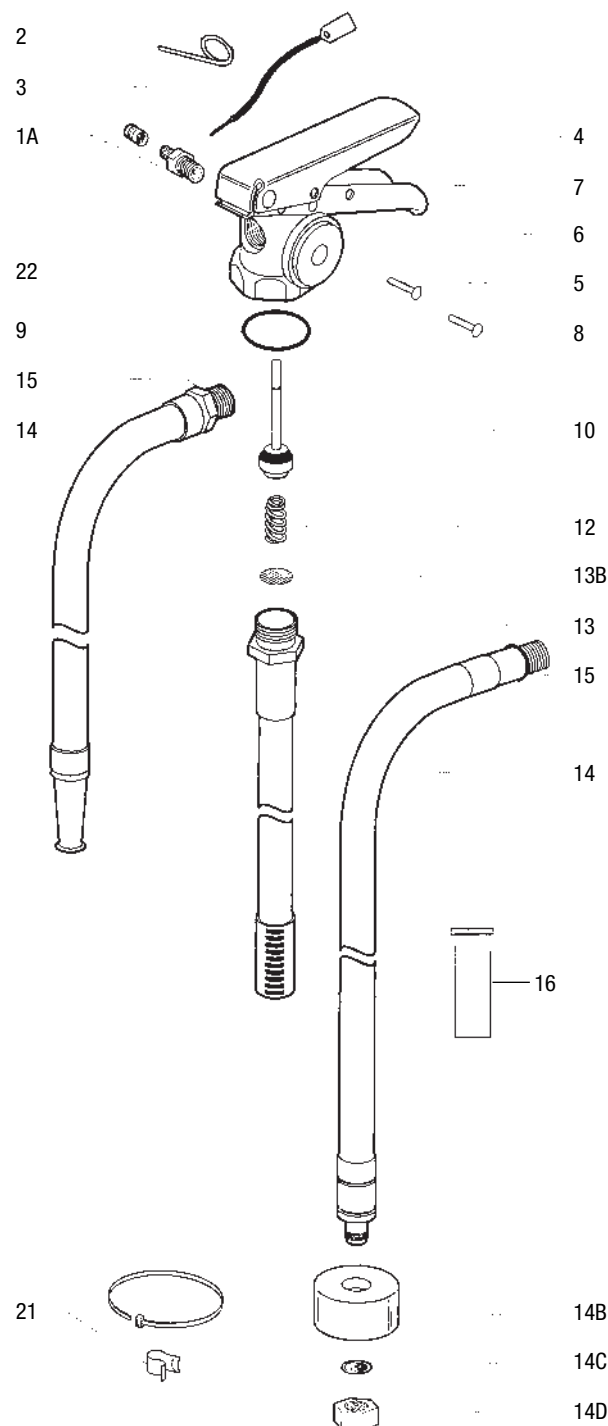
- WP61C AND KIDDE PRO-2.5 WM, 24231

WET CHEMICAL

- WC100, WC250 AND KIDDE PRO PLUS 100



FIG.	PART#	DESCRIPTION
2	SPP	Pull Pin
3	TS	Tamper Seal
4	B16438	Lever
5	B16633	Lever Rivet
6	OFG100	Gauge 100 (Oil Filled)
7	B16437	Handle
8	RV30	Handle Rivet (2 Required)
9	OR215	Collar O-Ring
10	B23795	Valve Stem Assembly
12	B7630	Spring
13	B14992	Siphon Tube Assembly, Pressure Water and WC-250
13	B21539	Siphon Tube Assembly, WC-100 and Kidde Pro Plus 100
13B	B22445	Screen Disk for Siphon Tube, WC-100C, WC-250C
14	BHA21	Hose & Nozzle Assembly, Pressure Water
14	B23161	Hose Assembly w/ Tip, (Replaces 22338), Wet Chemical
14B	B23162	Finger Guard WC-100C, WC-250C
14C	97054KR	Foil Inspection Disc, Pkg/10 WC-100, WC-250
14D	B23165	Nozzle Tip Cap, Each WC-100C, WC-250C
15	OR18	Hose O-Ring
16	B3728	Overfill Tube
21	UHS34/ UHC	Universal Hose Strap/Clip WC-100C, WC-250C, F-100C, F-250C



Discontinued

ACCESSORIES

FIG.	PART#	DESCRIPTION
N/S	B23168	Wet Chemical Recharge, 6 lit. WC-100C
1A	AVA*	Pressure Valve & Cap Assembly
N/S	RA11	Recharge Adapter, WP-61, WPA-61, WC-100, WC-250
N/S	CORE*	Pressure Valve Core, Pkg/50
N/S	AC40	Loaded Stream Anti-Freeze Charge Pressure Water
N/S	WH1	Wall Hanger
N/S	HTAA2	Hydrostatic Test Adapter

**PARTS AND PRICING FOR
PYRENE/BADGER AR-AFFF
WATER/LOADED STREAM - F100-C (6L),
F250-C (2 GAL.) AVAILABLE ON REQUEST**



DRY CHEMICAL 5-10-20-30 LB.

5HI-SA40-ABC	10HI-SB80-ABC	10T HI-SB80-ABC	20S HI-SA-ABC	30S HI-SB-ABC
5HI-SB40-ABC	10S HI-SA-ABC	10T HI-SA-STD	20S HI-SB-ABC	30S HI-SB-PK
5HI-SA-PK	10S HI-SA-STD	10T HI-SB-STD	20S HI-SA-STD	
5.5HI-SA40-STD	10S HI-SA-PK	10T HI-SA-PK	20S HI-SA-PK	
10HI-SA80-ABC	10T HI-SA80-ABC	10T HI-SB-PK	20S HI-SB-PK	

HALON 1211

5HI-SA-1211-A	9HI-SB-1211	13HI-SB-1211	20S-SA-1211
5HI-SB-1211-A	9S HI-SA-1211	13S HI-SA-1211	20S-SB-1211
9HI-SA-1211	13HI-SA-1211	17S-SA-1211	

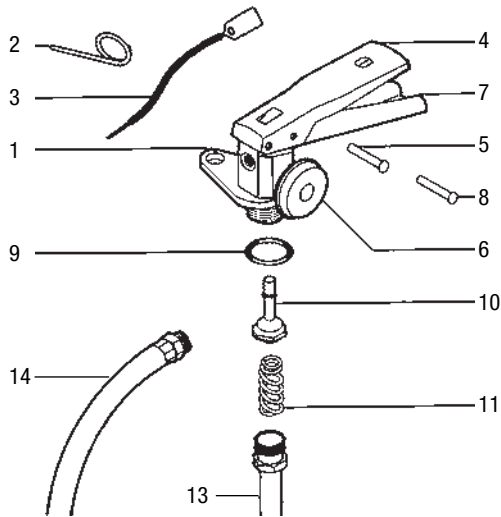


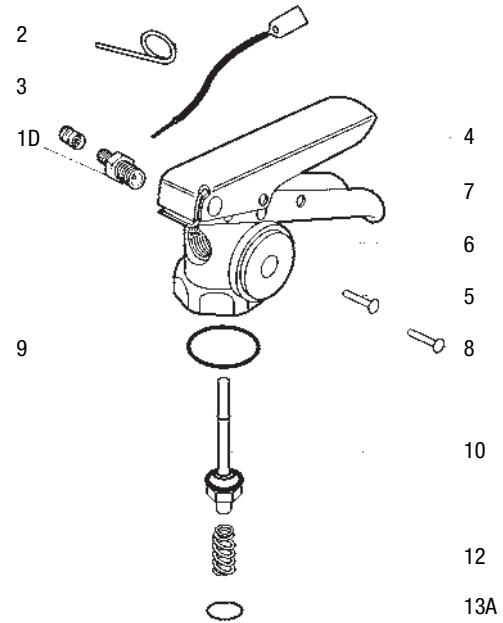
FIG.	PART#	DESCRIPTION	
1A	BU700201	Hanger Loop (SA)	
2	SPP	Pull Pin	
3	TS	Tamper Seal	
4	BU900210	Lever (SA)	
4	BU900214	Lever (SB)	
5	BU900050	Lever Rivet (SA)	
5	BU900053	Lever Rivet (SB)	
6	G195	Gauge - 195 All Dry Chemical	
6	HG100	Gauge - 100 Halon - All 5 lb	
6	G195H	Gauge - 195 Halon - All 9, 13, 17, 20 lbs	
6	G100T	Gauge - 100 Halotron 1 - All 5 & 11 lb	
6	G125T	Gauge - 125 Halotron 1 - All 12, 14 & 15 lb	
7	BU900228	Handle (SA)	
7	BU900232	Handle (SB)	
8	BU900049	Handle Rivet (SA)	
8	BU900052	Handle Rivet (SB)	
9	BU900001	Collar O-Ring	
9	OR117	Collar O-Ring - All Halon (900004)	
9	BU900010	Collar O-Ring	Discontinued
9	BU900013	Collar O-Ring All Steel Cylinder - Halotron 1	Discontinued
9	BU900014	Collar O-Ring All Aluminum Cylinder - Halotron 1	Discontinued
10	BU103215	Valve Stem - All Dry Chemical	
10	BU103214	Valve Stem - All Halon	
10	BU103216	Valve Stem - All Halotron I	
12	BU900105	Spring (replaces 900101)	
13	BU900960	Siphon Tube - All 5 HI, 5.5 HI	
13	BU900962	Siphon Tube - All 10S HI	
13	BU900963	Siphon Tube - All 10T HI	
13	BU900971	Siphon Tube - All 10 HI, 20 HI 5 HI SA 40 ABC	
14	BU113277	Hoze and Nozzle Assembly (.144) 0 HI SA80 ABC & 10T HI SA 80 ABC	
14	BU126216	Hoze and Nozzle Assembly (.180) 20S HI SA ABC	
N/S	RA20	Recharge Adapter	
N/S	HTABU1	Hydrostatic Test Adapter	

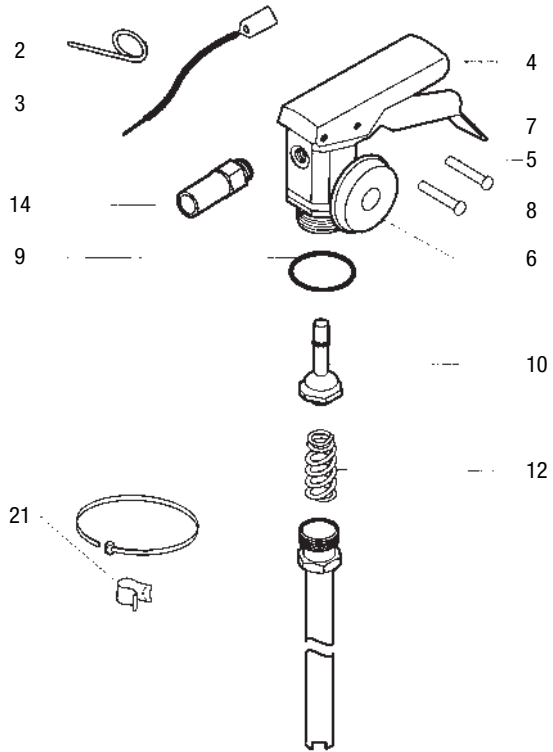


FIG.	PART#	DESCRIPTION
2	SPP	Pull Pin (Stainless Steel)
3	TS	Tamper Seal
4	BU900322	Lever
5	BU900053	Lever Rivet
6	G100K	Gauge - 100 psi
7	BU900919	Handle
8	BU900052	Handle Rivet
9	BU900916	Collar-O-Ring
10	BU900921	Valve Stem Assembly
12	BU900928	Spring
13	BU300465	SiphonTube, 6 ltr.
13	BU300464	SiphonTube, 2.5 gal.
13A	BU900930	Siphon Tube O-Ring
14	WC6LDA	Hose Wand & Assembly w/Nozzel, 6 ltr.
14	BU900637	Hose Wand & Assembly w/Nozzel, 2.5 gal.
14A	BUNOZ001WCA	Nozzle Assembly, 6 ltr.
14A	BU900936	Nozzle Assembly, 2.5 gal.
15	BU900941	Hose O-Ring
N/S	BU600872	Wet Chemical Charge, 6 ltr.

Discontinued

WET CHEMICAL - 6 LTR., 2.5 GAL.





DRY CHEMICAL

2 STD-100 2.5 STD-100 2.5 PK-100 2.5 SA ABC 2.5 SA PK
 2 PK-100 2.5 ABC-100 M-5 ABC-II-100 2.5 SA STD

HALON 1211

1-1211 2.2-1211 2.5-1211

HALOTRON 1

2.5 LB. & 3 LB. MODELS 2.5 F SA 2.5 H SA

FIG.	PART#	DESCRIPTION
2	SPP	Pull Pin
3	TS	Tamper Seal
4	BU900209	Lever (Aluminum Cylinders)
4	BU900217	Lever (Steel Cylinders)
5	BU900053	Lever Rivet
6	G100	Gauge 100 - All Dry Chemical
6	HG100	Gauge 100 (Halon) - All Halon
6	G100T	Gauge 100 (Halotron I) - All Halotron I
7	BU900218	Handle (Steel Cylinders)
8	BU900049	Handle Rivet
9	OR117	Collar O-Ring (Aluminum Cylinders) - Dry Chemical and Halon 1211(900004)
9	BU900001	Collar O-Ring (Steel Cylinders) - Dry Chemical and Halon 1211
9	BU900014	Collar O-Ring (Aluminum Cylinders) - Halotron I
9	BU900013	Collar O-Ring (Steel Cylinders) - Halotron I
10	BU103215	Valve Stem - All Dry Chemical
10	BU103214	Valve Stem - All Halon
10	BU103216	Valve Stem - All Halotron I
12	BU900105	Spring
14	BU101145	Nozzle - 2.5 ABC-100, 2.5 STD-100

Discontinued

ACCESSORIES

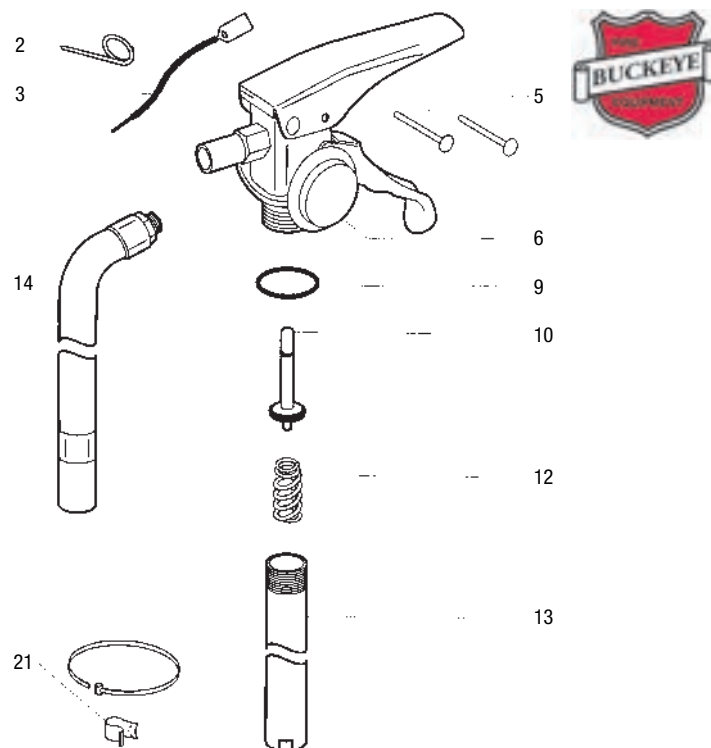
FIG.	PART#	DESCRIPTION
N/S	RA20	Recharge Adapter
N/S	HTABU1	Hydrostatic Test Adapter

**DRY CHEMICAL AND HALON 1211
OLDER MODELS (1 1/8" VALVES 1975 TO 1984 AND
1 1/4" VALVES PRIOR TO 1975)**

FIG.	PART#	DESCRIPTION
2	SPP	Pull Pin
3	TS	Tamper Seal
5	RV38	Lever Handle Rivet (900042 Obsolete)
6	G195	Gauge - 195 - Dry Chemical
6	G240	Gauge 240 - Dry Chemical
6	HG100	Gauge 100 (Halon)
9	BU900001	Collar O-Ring - Dry Chemical
9	OR117	Collar O-Ring - Halon (900004)
10	BU103214	Valve Stem - All 1 1/8" Valves (After Oct. 1975)
10	WVS13	Valve Stem (100214 Obsolete) - Dry Chemical 1 1/8" Valve (After Oct. 1975)
12	BU900105	Spring (Replaces 900101)
13	BU115240	Siphon Tube (ST18) 18 1/2"
13	BU117240	Siphon Tube (ST21) 21"
14	BU113260	

Discontinued

Discontinued



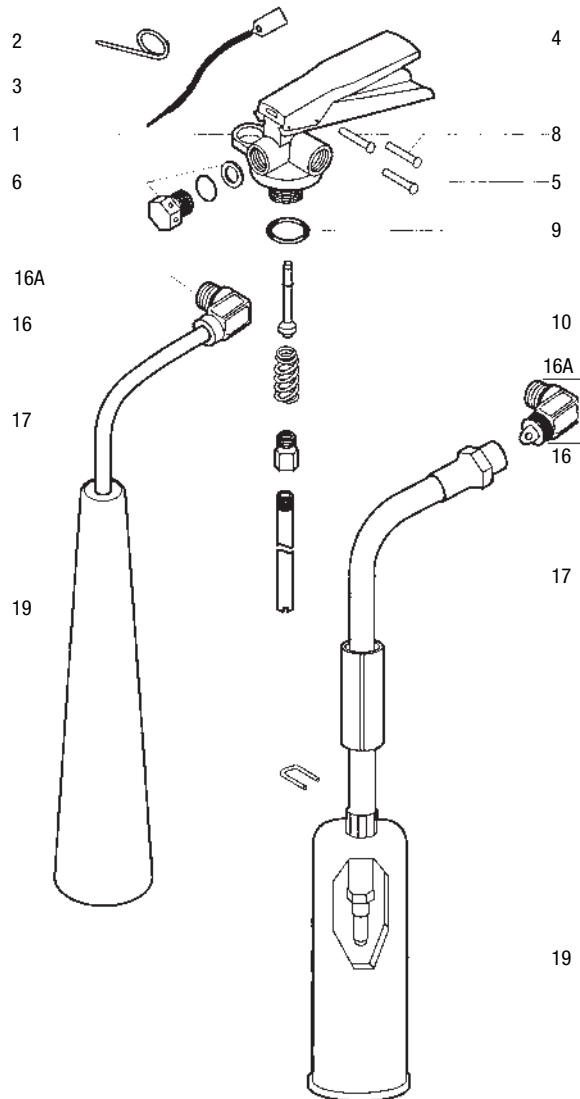
ACCESSORIES

FIG.	PART#	DESCRIPTION
N/S	RA20	Recharge Adapter
N/S	HTABU1	Hydrostatic Test Adapter

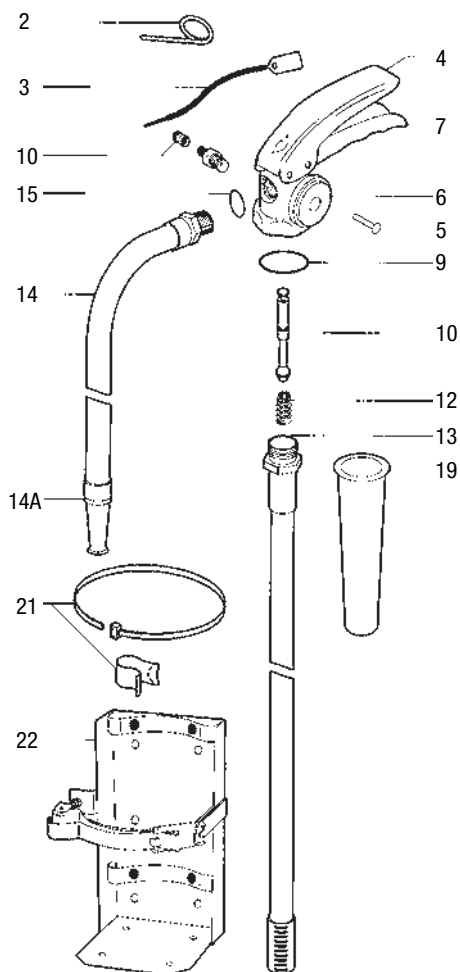
CARBON DIOXIDE BUCKEYE

451 456 461 466

FIG.	PART#	DESCRIPTION
2	SPP	Pull Pin, Stainless Steel
3	TS	Tamper Seal
4	BU900322	Lever (200083)
5	BU900053	Lever Rivet
6	BU200081	Safety Disc, Gasket & Nut Assy.
8	BU900052	Handle Rivet
9	OR216A	Collar O-Ring (900329)
10	BU900321	Valve Stem Assembly
16	BU450202	Elbow w/O-Ring - 5 lb
16A	BU900331	Elbow w/O-Ring
17	BU453231	Hose & Nose Assembly- 10, 15 & 20 lb
17	BU900310	Swivel - Discharge Tube - 5 lb
19	BU900313	Horn - 5 lb
19	BU900314	Horn w/ Handle - 10, 15, 20 lb
N/S	ARD	Hose Band - 10, 15 & 20 lb
N/S	BL209	Replacement Nameplate (non UL) 5 lb
N/S	BL210	Replacement Nameplate (non UL) 10-20 lb
N/S	WH5	Wall Hanger - 5 lb
N/S	WH10	Wall Hanger - 10, 15 lb
N/S	WH20	Wall Hanger - 20



**FLAG
FIRE**

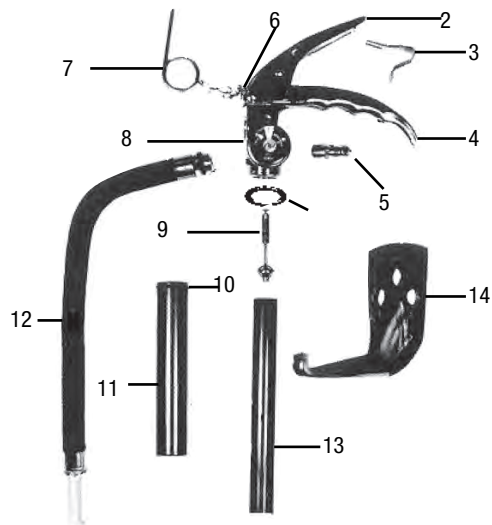


**FLAG WATER -PWS25G
WET CHEMICAL - KS6000 - OLDER MODEL**

FIG.	PART#	DESCRIPTION	
2	AS430115	Pull Pin	
3	TS	Tamper Seal	
4	AS430924	Lever	
5	AS430250	Rivet	
6	OFG100	Pressure Gauge - 100 PSI	
7	AS430273	Handle (F11329) - Steel	
9	AS56909	Collar O-Ring	
10	AS429099	Valve Stem Assembly	
12	AS430004	Spring	
13	AS439713	Pick Up Tube Assembly - KS6000	
13	AS430793	Pick Up Tube Assembly - PWS25G	
14	AS430055	Hose & Nozzle Assembly - KS6000	Discontinued
14	AS429543	Hose & Nozzle Assembly - PWS25G	
14A	AS426074	Nozzle Tip - KS6000	
15	AS429544	Hose O-Ring	
19	AS429541	Fill Tube	
N/S	F430792	Valve Assembly - PWS25G	Discontinued
N/S	F430271	Valve Assembly - KS6000	Discontinued
N/S	AS430274	Collar Nut	
N/S	AS429539	Valve Stem O'Ring	Discontinued
N/S	PC553176	6 Litres of PyroChem Wet Chemical	
N/S	PC300	3 Gal. PyroChem Wet Chemical	

ACCESSORIES

FIG.	PART#	DESCRIPTION
1D	AVA	Pressure Valve & Cap Assembly - PWS25G
N/S	CORE	Pressure Valve Core, Pkg/50
21	UHS34/UHC	Universal Hose Strap/Clip
22	VB8	Heavy-Duty Vehicle Bracket
N/S	WH1	Wall Hanger
N/S	RA11	Recharge Adapter - KS6000



**FLAG PRESSURIZED WATER - OLDER MODEL -
PWS-25-F**

FIG.	PART#	DESCRIPTION	
1	OR212	Collar O-Ring (Flag Type 10513)	
3	FL105HP	Lever (Flag Type 10515)	
3	FLS	Spring (Flag Type 10426)	
4	F429160	Handle (10444)	Discontinued
5	AVA	Air Valve Assembly	
6	RV85	Rivet (Lever) (10296) Flag Type	
7	SPP	Pull Pin	
8	OFG100	Pressure Gauge - 100 PSI	
9	FVS4	Valve Stem Plunger Assy. (10990) Flag Type	
10	OR120	O-Ring (10447) Flag Type (Over Flow Tube)	
11	AS429541	Over Flow Tube Assembly	
12	FHA01	Hose Assembly (3760) Flag Type	Discontinued
13	AS430793	Syphon Tube (F10960)	
14	F40	Wall Bracket - 20 - 30 lb (10518 Flag Type)	
N/S	AC40	Anti-Freeze Charge	
N/S	KC1	Corrosion Inhibitor	Discontinued
N/S	HTAF4	Hydrostatic Test Adapter with Fine Thread N/S	

**FLAG
FIRE**

**FLAG DRY CHEMICAL - 2½ C, 5 LBS G&I -
OLDER MODELS**

FIG.	PART#	DESCRIPTION
1	SPP	Pull Pin
2	TS	Tamper Seal
3	F552003	Lever (10785) Discontinued
4	RV86	Rivet& Handle (New Style Lever) (10964) Flag Type Discontinued
5	G175	Gauge - 175 PSI
6	F551979	Handle (10784) Discontinued
7	OR117	Collar O-Ring (Flag Type 10418)
8	FVS1	Valve Stem (Flag Type 11130)
8	F552143	Valve Stem (ABC025C, ABC050G&I) Discontinued
9	FLS	Leaf Spring (Flag Type 10426)
10	FH30	Hose & Nozzle Assembly - ABC 5 lb Discontinued
10	F0251185	Nozzle - 2½ lb Discontinued
11	F11369	Syphon Tube Discontinued

Discontinued

Discontinued

Discontinued

Discontinued

Discontinued

Discontinued

Discontinued

HALON - 3½ - 7 LBS

FIG.	PART#	DESCRIPTION
N/S	F1269	Halon Nozzle for 3½ lb Discontinued
N/S	F1271	Halon Nozzle for 7 lb. As Stock Allows Discontinued

Discontinued

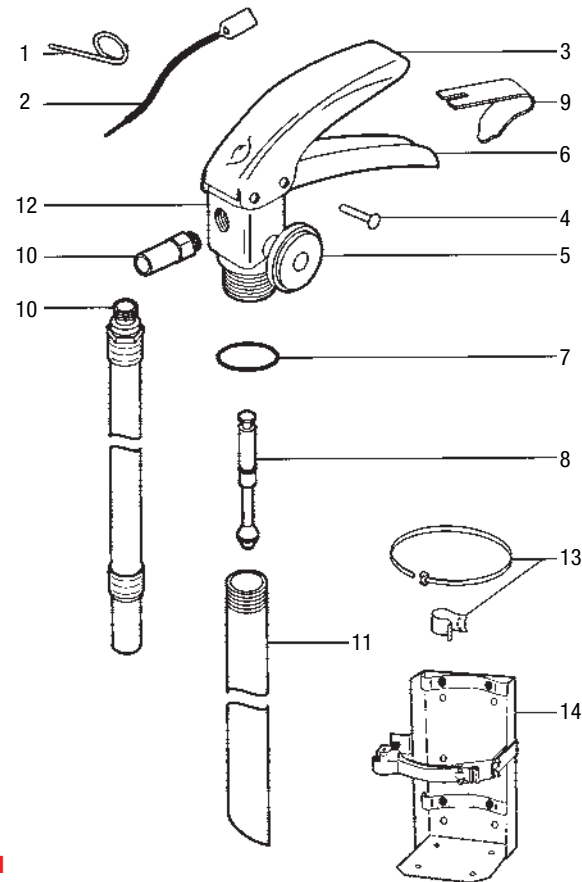
Discontinued

ACCESSORIES

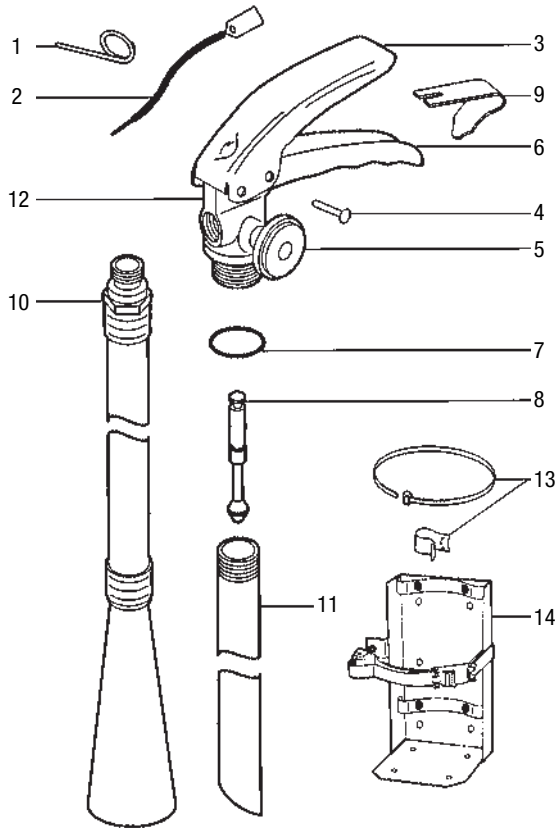
FIG.	PART#	DESCRIPTION
13	UHS34/UHC	Universal Hose Strap/Clip - 5 lb
14	VB4	Heavy Duty Vehicle Bracket - 5 lb
N/S	F11680	2½ - 3½ lb. Vehicle Bracket (Dry Chemical & Halon) Discontinued
N/S	F11690	5 - 7 lb. Vehicle Bracket (Dry Chemical & Halon) Discontinued
N/S	F10	Wall Bracket - 2½ - 7 lb (10368 Flag Type)
N/S	RA11	Recharge Adapter
N/S	HTAF1	Hydrostatic Test Adapter

Discontinued

Discontinued



**FLAG
FIRE**



**FLAG DRY CHEMICAL - 10 - 30 LBS G -
OLDER MODELS**

FIG.	PART#	DESCRIPTION	
1	SPP	Pull Pin	
2	TS	Tamper Seal	
3	FL105HP	Lever (10515) Flag Type	
4	RV85	Rivet - Lever & Handle (10296) Flag Type	
5	G175	Gauge - 175 PSI	
6	F429160	Handle (10444)	Discontinued
7	OR212	Collar O-Ring (Flag Type 10513)	
8	FVS4	Valve Stem (Flag Type 10990)	
9	FLS	Spring (Flag Type 10426)	
10	FH50	Hose & Nozzle Assembly 10 lb - ABC, BC (Flag Type 11950)	Discontinued
10	FH70	Hose & Nozzle Assembly 20 lb - ABC (Flag Type 11970)	Discontinued
10	FH660	Hose & Nozzle Assembly 30 lb - ABC (Flag Type 11660)	Discontinued
11	F11372	10 lb Syphon Tube	Discontinued
11	F11373	20 lb Syphon Tube (F11001 Valve Body Discontinued)	Discontinued

ACCESSORIES

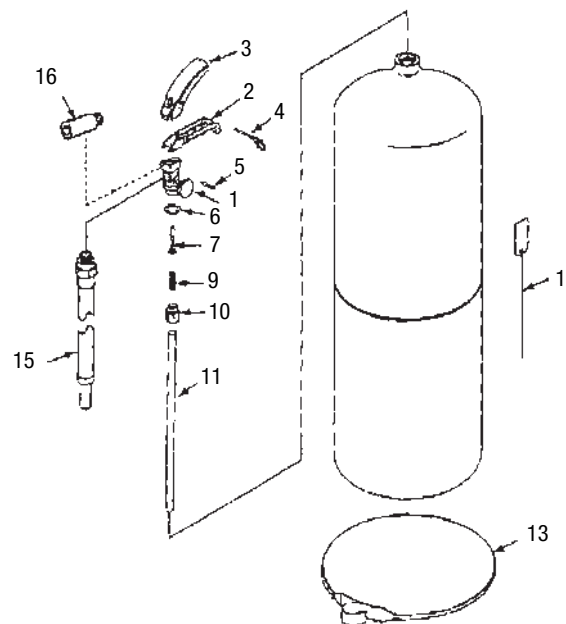
FIG.	PART#	DESCRIPTION
13	UHS34/UHC	Universal Hose Strap/Clip - 5 lb
14	VB6	Heavy Duty Vehicle Bracket - 10 lb
14	VB7	Heavy Duty Vehicle Bracket - 20-30 lb
N/S	F30	Wall Bracket - 10 lb (10519 Flag Type)
N/S	F40	Wall Bracket - 20 - 30 lb (10518 Flag Type)
N/S	RA11	Recharge Adapter
N/S	HTABU1	Hydrostatic Test Adapter
N/S	HTAF4	Hydrostatic Test Adapter with Fine Thread
N/S	HTAF5	Hydrostatic Test Adapter with Coarse Thread

**FLAG
FIRE**

FLAG
2½ – 5 LB DRY CHEMICAL – MODELS D-V, J, K
ABC-0250-D-V – 2½ LB ABC
ABC-050-J – 5 LB ABC
ABC-050-K – 5 LB ABC

FIG.	PART#	DESCRIPTION
1	F551978	Gauge – 195 PSI
2	F551979	Handle – Black
3	F552003	Lever – Black
4	SPP	Pull Pin
5	F552016	Rivet
6	OR117	O-Ring, Collar
7	F552143	Valve Stem Assembly
9	F415565	Spring
10	F431719	Pick-up Tube Adapter
11	F431730	Pick-up Tube (ABC-025-D-V, ABC-050-J)
11	F431731	Pick-up Tube (ABC-050-K)
12	TS	Tamper Seal
15	F552638	Hose Assembly (ABC-050-J)
15	F551981	Hose Assembly (ABC-050-K)
16	F552163	Nozzle

Discontinued
Discontinued
Discontinued
Discontinued
Discontinued
Discontinued
Discontinued
Discontinued
Discontinued
Discontinued
Discontinued
Discontinued



ACCESSORIES

FIG.	PART#	DESCRIPTION
13	UHS34/UHC	Universal Hose Strap/Clip
N/S	WH1	Wall Hanger
N/S	VB5	Heavy Duty Vehicle Bracket
N/S	RA16	Recharge Adaptor Hydrostatic Test Adapter

MODELS ABC025B, ABC050H, ABC10H, PDC10H,
ABC20H, ABC30H
2½ LB - 30 LB DRY CHEMICAL

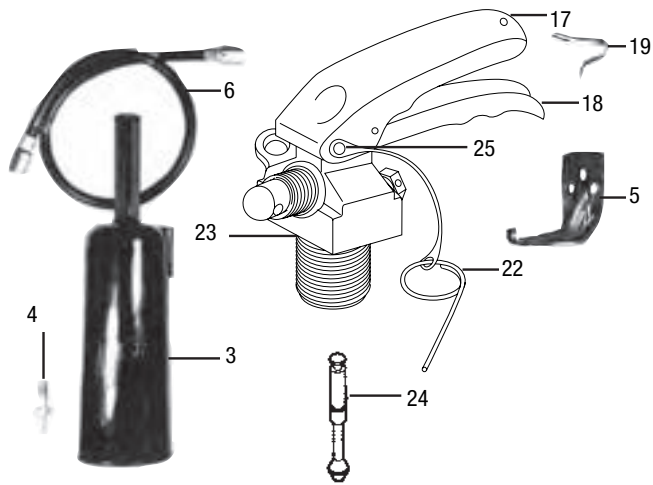
FIG.	PART#	DESCRIPTION
1	F551978	Gauge – 195 PSI
2	F551979	Handle - 2½, 5 LB.
2	F429160	Handle - 10 to 30 LB.
3	F552003	Lever - 2½, 5 LB.
3	AS429163	Lever - 10 to 30 LB.
4	F429172	Pull Pin
5	F552016	Rivet - 2½, 5 LB.
5	AS429165	Rivet - 10 to 30 LB. - Stainless Steel
6	F552007	O-Ring (Listed to -65°F)
6	F429159	O-Ring (Listed to -65°F)
7	F552143	Plunger Assembly - 2½, 5 LB.
7	F552144	Plunger Assembly - 10 to 30 LB.
9	F415565	Spring
10	F431719	Pick-up Tube Adapter - 2½, 5 LB.
11	AS431732	Pick-up Tube - 10 LB.
11	AS431733	Pick-up Tube - 20 LB.

Discontinued
Discontinued
Discontinued
Discontinued
Discontinued
Discontinued
Discontinued
Discontinued
Discontinued
Discontinued
Discontinued
Discontinued
Discontinued

FIG.	PART#	DESCRIPTION
11	AS431734	Pick-up Tube - 30 LB.
12	TS	Tamper Seal
13	F427995	Hose Clip Band
14	F551981	ABC 5 LB. Hose Assembly
14	AS551997	ABC 10 LB. Hose Assembly
14	AS552145	ABC 20 LB. Hose Assembly
14	AS552146	ABC 30 LB. Hose Assembly
14	F551983	PDC 20 LB. Hose Assembly
15	F552154	Nozzle
N/S	F552017	Wall Bracket - 2½, 5 LB.
N/S	F552018	Wall Bracket - 10 LB.
N/S	AS428224	Wall Bracket - 20, 30 LB.
N/S	RA16	Recharge Adapter - 2½, 5 LB.
N/S	F550130	Recharge Adapter - 10 to 30 LB.

Discontinued
Discontinued
Discontinued
Discontinued
Discontinued
Discontinued
Discontinued
Discontinued
Discontinued
Discontinued
Discontinued

**FLAG
FIRE**



**FLAG CARBON DIOXIDE CO2 H MODELS -
10, 15, 20 LBS - OLDER MODELS**

FIG.	PART#	DESCRIPTION
3	F1072	Horn
4	F1231	Nozzle (10)
4	F10522	Nozzle (15 & 20)
5	F40	Wall Bracket (10518) Flag Type
6	363	3/8" F x 3/8" F x 36" CO2 Hose
N/S	RS10	Band (10) OEM Part #1415
N/S	RS15	Band (15) OEM Part #1416
N/S	RS20	Band (10) OEM Part #1417
N/S	FSET	Horn Clamp Set (RH, LH, Screws & Nuts)

Discontinued

**FLAG CARBON DIOXIDE CO2 H MODELS -
5 LBS - OLDER MODELS**

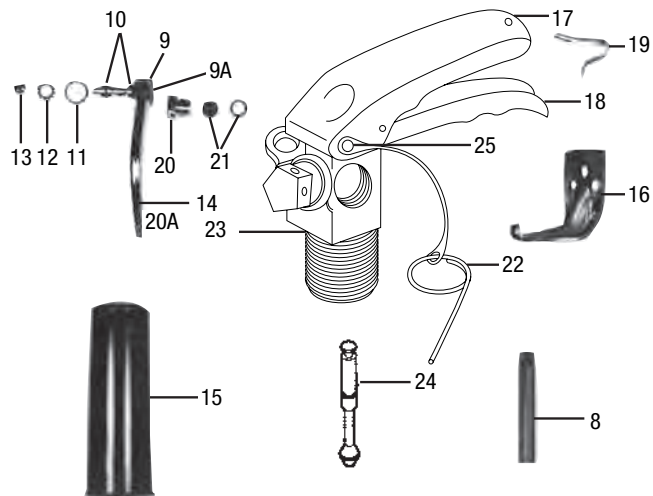


FIG.	PART#	DESCRIPTION
8	F1423	Syphon Tube
9	F1328	Swivel (10505) Old Style
9A	F100060	Swivel - New Style
10	OR012	O-Ring (10192) Flag Type (Swivel Assy.)
11	F429976	Gasket (Swivel Assy.) (10194)
12	F10193	Lock Washer (Swivel Assy.)
13	F10195	Nut (Swivel Assy.)
14	F100060	Swivel Tube Assembly
15	F429184	Horn (10204)
N/S	F429183	Washer (Horn) (10233)
N/S	F429185	Nozzle (Horn) (1062)
16	F20	Wall Bracket (10507) Flag Type

Discontinued

Discontinued

Discontinued

Discontinued

Discontinued

**CARBON DIOXIDE CO2 H MODELS - OLDER MODELS
COMMON PARTS 5, 10, 15, 20 LBS - OLDER MODELS**

FIG.	PART#	DESCRIPTION
17	FL105HP	Lever (Flag Type) 10515
18	F429160	Handle (10444)
19	FLS	Spring (Flag Type 10426)
20	F10065	Safety Disc Nut
20A	F429515	Safety Plug Assembly
21	F10066	Safety Disc & Washer
22	SPP	Pull Pin
23	OR216A	O-Ring (Flag Type 10635) (Valve Body)
24	FVS10	Flag Type Valve Stem (11720)
25	RV85	Rivet (Lever) (10296) Flag Type

Discontinued

Discontinued

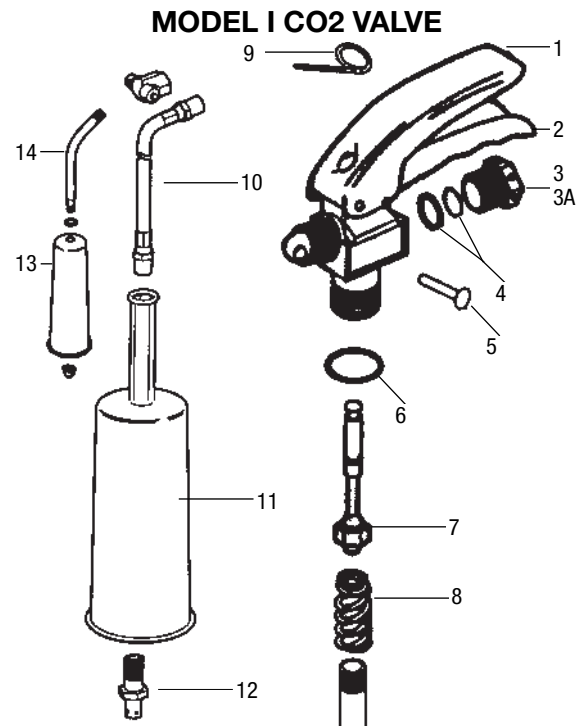
**FLAG CARBON DIOXIDE 5 - 20 LB -
MODEL I**

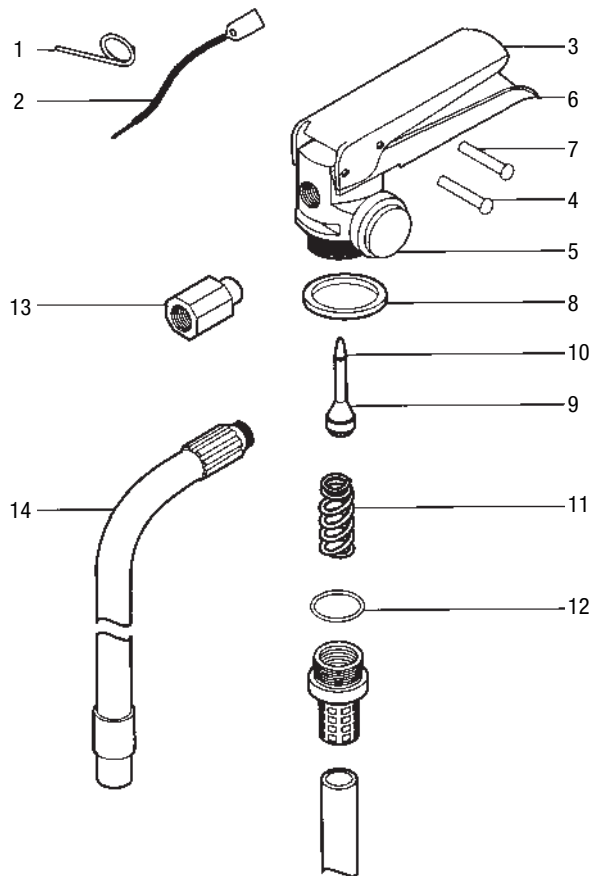
**FLAG
FIRE**

FIG.	PART#	DESCRIPTION
1	FL105HP	Lever (Flag Type) 10515
2	F429160	Handle (10444)
3	F10065	Safety Nut
3A	F429515	Safety Plug Assembly
4	F10066	Safety Disc & Washer
5	RV85	Rivet (Lever) (10296) Flag Type
6	OR216A	Collar O-Ring (Flag Type 10635) (Valve Body)
7	FVS10	Valve Stem (Flag Type 11720)
8	F415565	Spring
9	SPP	Pull Pin
10	363	3/8" F x 3/8" F x 36" CO2 Hose
11	AN429197	Horn, 10, 15 & 20, 50#
12	F1231	Nozzle 10 lb.
12	F10522	Nozzle 15 & 20 lb.
13	F429184	Horn (10204)
14	F100060	Swivel Tube Assembly

Discontinued
Discontinued

Discontinued





DRY CHEMICAL

PRO2.62TCM-5 PRO4TCM-4 PRO6RM-4 PRO10RM-5 PRO20TCM-5 PRO20PKM-3
 PRO2.75RM-5 PRO5TCM-4 PRO10TCM-5 PRO10PKM-3 PRO20RM-5

FIG.	PART#	DESCRIPTION
1	SPP	Pull Pin
2	TS	Tamper Seal
3	B18363	Lever
4	B18404	Lever Rivet
5	G100	Gauge - 100 PSI - 2.62 - 4 lbs
5	G195	Gauge - 195 PSI - 5 - 20 lbs
6	B18361	Handle
7	RV30	Handle Rivet (16517)
8	OR212	Collar O-Ring Neck Seal
9	P440068K	Valve Stem
10	K259772	Valve Stem O-Ring
11	K320732	Spring
12	P320167K	Syphon Tube O-Ring
13	P320337K	Nozzle - PRO2.62TCM-5, PRO2.5TCM-6, PRO2.5MP
14	P440089	Hose & Nozzle Assembly - PRO5TCM-4, PRO5MP
14	P440257	Hose & Nozzle Assembly - PRO10RM-5
14	P440330	Hose & Nozzle Assembly - PRO20TCM-5
N/S	RA20	Recharge Adapter
N/S	HTA45	Hydrostatic Test Adapter

Discontinued

Discontinued

DRY CHEMICAL (FROM 1991)

2 $\frac{3}{4}$ RM-2, -3, -4 4TCM-3 6RM-2, -3 10TCM-2 20TCM-2, -3
 2 $\frac{5}{8}$ TCM-2, -3, -4 5TCM-2, -3 10RM-2 20RM-2, -3

HALON (FROM 1991)

2.5HM-2, -3 5HM-2, -3 9HM-2, -3 13HM-3 17HM-2 20HM-2

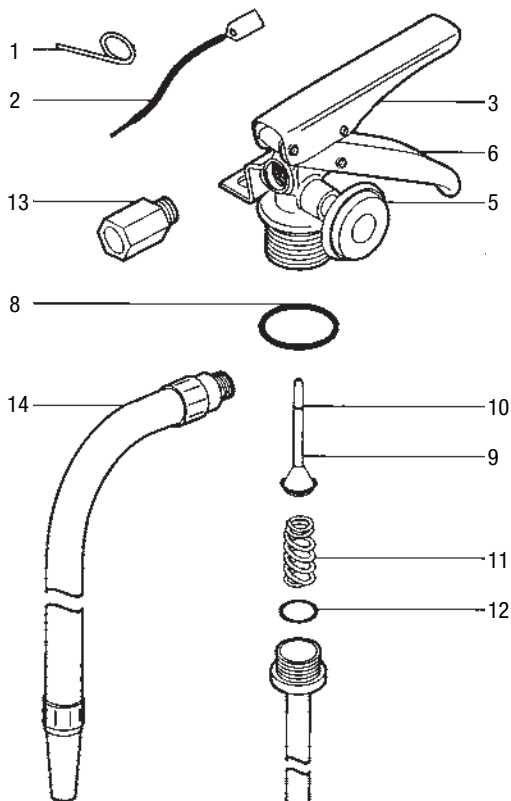


FIG.	PART#	DESCRIPTION
1	SPP	Pull Pin
2	TS	Tamper Seal
3	P300489K	Lever, Replaces 320189 - 2.62TCM-2, 2.75RM-2, 5TCM-2, All 10 - 20 lbs.
5	G100	Gauge - 100 PSI - 2L - 4lbs Dry Chemical
5	G195	Gauge - 195 PSI - 5 - 20 lbs
5	HG100	Gauge - 100 PSI - 2L - 6lbs Halon
5	G195H	Gauge - 195 PSI - 9 - 20 lbs Halon
8	B340035	Collar Seal - All Dry Chemical & Halon
9	K440020	Valve Stem - All Dry Chemical
10	K259772	Valve Stem O-Ring - All Dry Chemical
11	K320143	Spring - All Dry Chemical
12	P320167K	Syphon Tube O-Ring
13	P320337K	Nozzle - 2.62 TCM-3, 2 $\frac{5}{8}$ TCM-3, 2 $\frac{5}{8}$ TCM-4
14	P440089	Hose & Nozzle Assembly - 5TCM-2, 5TCM-3
N/S	RA20	Recharge Adapter (Large Units)
N/S	RA35	Recharge Adapter (Small Units)
N/S	HTAK8	Hydrostatic Test Adapter

Discontinued

Discontinued

Discontinued

Discontinued

DRY CHEMICAL

10TAP 10RAP XL10TCZ XL10TCZ-2 XL10RZ XL10RZ-2

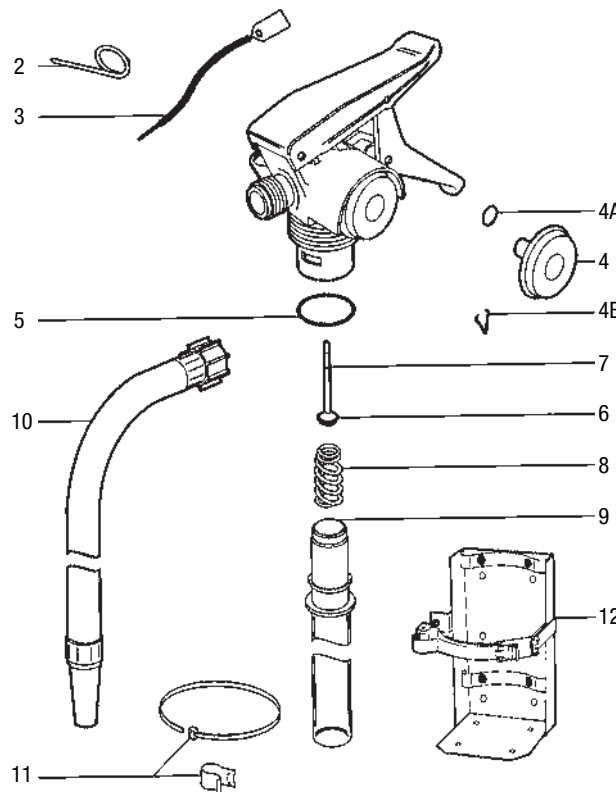


FIG.	PART#	DESCRIPTION
2	SPP	Pull Pin
3	TS	Tamper Seal
4	K293266	Gauge - 195 PSI
4A	K259535	Gauge O-Ring
5	K340037	Collar Seal - Newer with Molded Seal
6	K877546	Valve Stem
7	K259772	Valve Stem O-Ring
8	K259749	Spring
9	K420001	Syphon Tube Assembly - 10TAP, 10RAP, XL10TCZ, XL10RZ
10	K878291	Hose - 10TAP, XL10TCZ, XL10TCZ-2

Discontinued

Discontinued

Discontinued



ACCESSORIES

FIG.	PART#	DESCRIPTION
11	UHS34/UHC	Universal Hose Strap/Clip
N/S	WH10	Wall Hanger
12	VB4	Vehicle Bracket
N/S	RA22	Recharge Adapter
N/S	HTAK39	Hydrostatic Test Adapter

DRY CHEMICAL

XL5TCZ 6# TAP 2A40BC (W/HOSE) XL6RZ 6# RAP 40 BC

HALON 1211

AC-2.5

FIG.	PART#	DESCRIPTION
1	K440016	Valve, Lever & Handle Assembly
2	K259057	Pull Pin
3	K293266	Gauge - 195 PSI - Dry Chemical
3A	K259535	Gauge O-Ring - Dry Chemical
3A	K260613	Gauge O-Ring - Halon
4	B340035	Collar O-Ring - All
5	K440007	Valve Stem - Halon
5	K877546	Valve Stem - Dry Chemical
6	K259772	Valve Stem O-Ring - Dry Chemical
7	K259749	Spring - Dry Chemical
8	K420041	Syphon Tube Assembly - AC-2.5
8	K420042	Syphon Tube Assembly - #6TAP, 2A40BC (w/Hose), XL6RZ, 6#RAP, 40BC
8	K420064	Syphon Tube Assembly - XL5TCZ
9	K440002	Hose - 6#TAP, 2A40BC (w/Hose)
N/S	RA22	Recharge Adapter
N/S	HTAK8	Hydrostatic Test Adapter

Discontinued

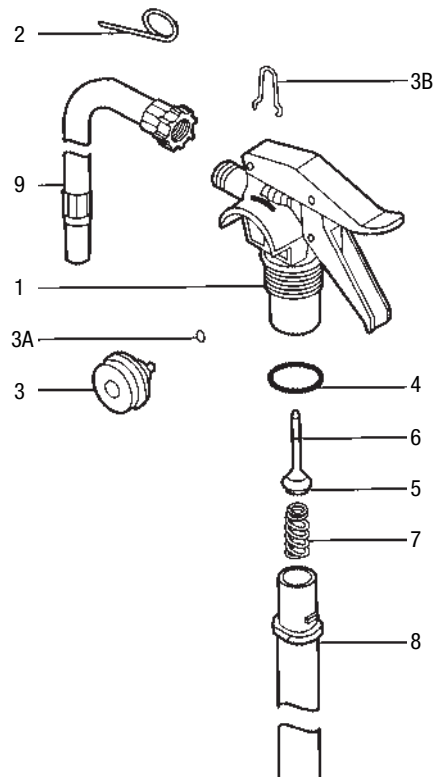
Discontinued

Discontinued

Discontinued

Discontinued

Discontinued





DRY CHEMICAL

XL2.5TCZ 1A10BC XL2.75RZ-3 EXT 2A40BC (W/NOZZLE)
 XL2.5TCZ-3 XL2.75RZ 10BC EXT 6# BC

HALON 1211

XL2.5HZ HAL2.5 12115BC XL5HZ HAL5A XL9HZ 9#HALON

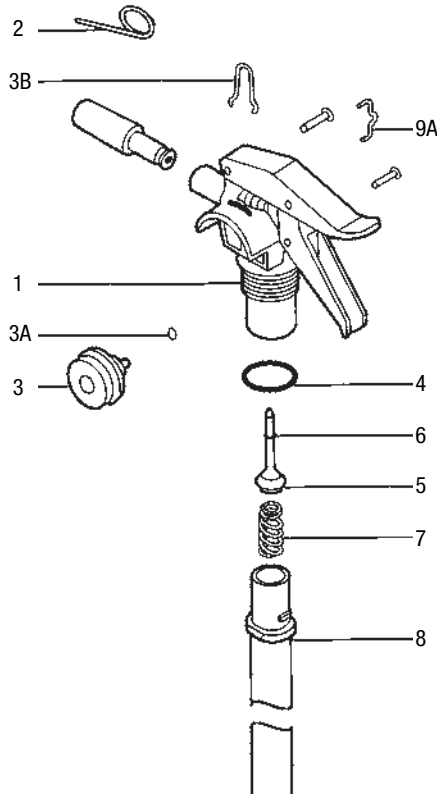
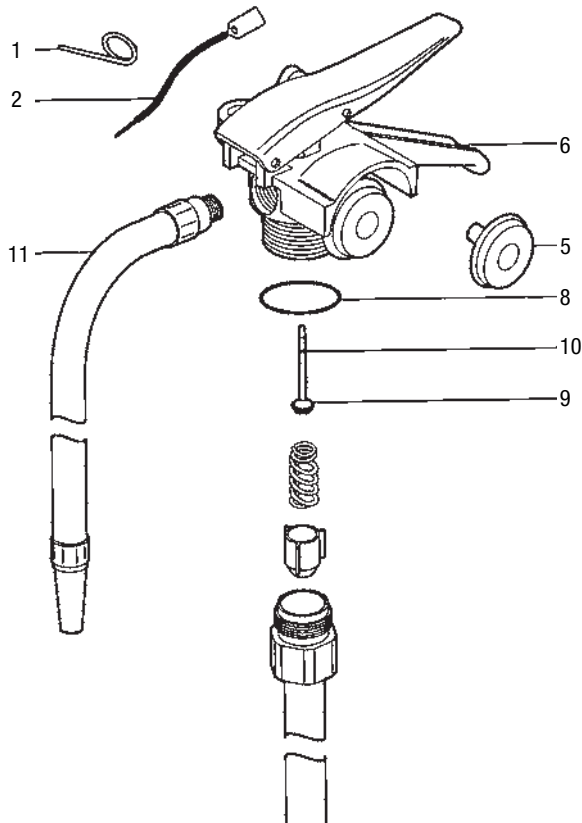


FIG.	PART#	DESCRIPTION	
1	K440015	Valve Body Assembly - All Except XL2.5TCZ-3, XL2.75RZ-3, XL9HZ, 9#HALON	Discontinued
2	K259057	Pull Pin	
3	K293266	Gauge - 195 PSI - EXT 2A40BC, EXT 6#BC	
3	K293789	Gauge - 100 PSI - Dry Chemical, Except EXT 2A40BC, EXT 6#BC	
3A	K259535	Gauge O-Ring - Dry Chemical	
3A	K260613	Gauge O-Ring - Halon	Discontinued
4	B340035	Collar O-Ring - All	
5	K440007	Valve Stem - Halon	
5	K877546	Valve Stem - Dry Chemical	
6	K259772	Valve Stem O-Ring - Dry Chemical	
7	K259749	Spring - Dry Chemical	Discontinued
8	K420041	Syphon Tube Assembly - XL2.5tcz, xl.275tcz, 1A10BC, 10BC, XL2.5HZ, HAL2.5, 1211 5BC	Discontinued
8	K420042	Syphon Tube Assembly - EXT 2A40BC, EXT 6#BC	Discontinued
9A	K259770	Nozzle Clip	
N/S	RA19	Recharge Adapter	
N/S	HTAK8	Hydrostatic Test Adapter	
N/S	K466400	Bracket 5 & 6 lbs.	
N/S	K466401	Bracket 2½ & 2⅝ lbs.	



DRY CHEMICAL

10RAS-3, -4, -5, -6 20RAS-3, -4, -5, -6, -7 30RAS-3
 10TAS-3, -4, -5, -6 20TAS-3, -4, -5, -6, -7

FIG.	PART#	DESCRIPTION	
1	SPP	Pull Pin	
2	TS	Tamper Seal	
4	K218881	Spiral Pin	Discontinued
5	G195	Gauge - 195 PSI - All 10 lbs., 20RAS-7, 20TAS-7	
5	G235	Gauge - 235 PSI - All 20 lbs., (Except 20RAS-7, 20TAS-7) 30RAS-3	
6	K292602	Handle	
8	K340037	Collar Seal - 1985 and After	
8	OR218	Collar O-Ring - 1985 and Before (64350218)	
9	K877546	Valve Stem Assembly	
10	K259772	Valve Stem O-Ring	
N/S	RA15	Recharge Adapter	
N/S	HTAK1	Hydrostatic Test Adapter	

DRY CHEMICAL (FROM 1991)

2¾ RM-2, -3, -4 4TCM-3 6RM-2, -3 10TCM-2 20TCM-2, -3
 2½ TCM-2, -3, -4 5TCM-2, -3 10RM-2 20RM-2, -3

HALON 1211 (FROM 1991)

2.5HM-2, -3 5HM-2, -3 9HM-2, -3 13HM-3 17HM-2 20HM-2

FIG.	PART#	DESCRIPTION
1	SPP	Pull Pin
2	TS	Tamper Seal
3	P300489K	Lever, Replaces 320189
5	G100	Gauge - 100 PSI - 2½ - 4lbs. Dry Chemical
5	G195	Gauge - 195 PSI - 5 - 20lbs. Dry Chemical
5	HG100	Gauge - 100 PSI - All 2½ - 6lbs. HALON
5	G195H	Gauge - 195 PSI - All 9 - 20 lbs. HALON
8	B340035	Collar Seal - All Dry Chemical & Halon
8	K340037	Collar Seal - 10 - 20 lb. RM, RM-1, TCM, TCM-1
9	K440020	Valve Stem - All Dry Chemical
10	K259772	Valve Stem O-Ring - All Dry Chemical
11	K320143	Spring - All Dry Chemical
12	P320167K	Syphon Tube O-Ring
14	P440127	Hose & Nozzle Assembly -5TCM
N/S	RA20	Recharge Adapter (Large Units)
N/S	RA35	Recharge Adapter (Small Units)
N/S	HTAK8	Hydrostatic Test Adapter

Discontinued

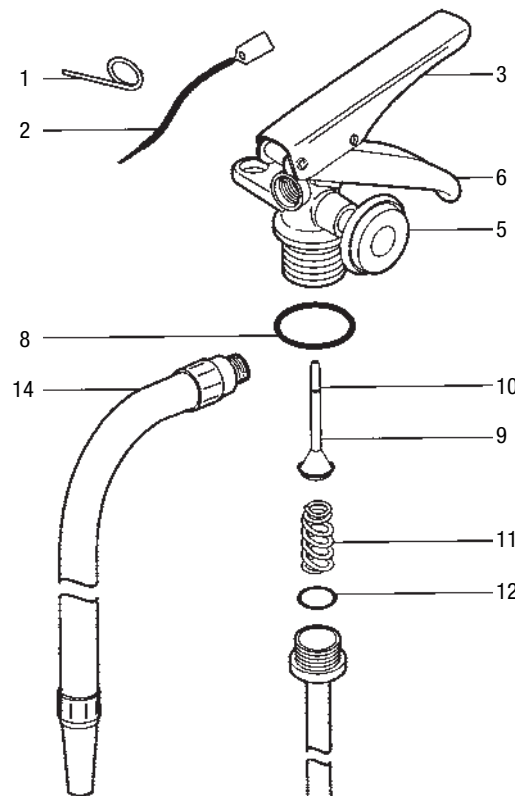
Discontinued

Discontinued

Discontinued



EXTINGUISHER PICTOGRAMS - PYRENE/KIDDE

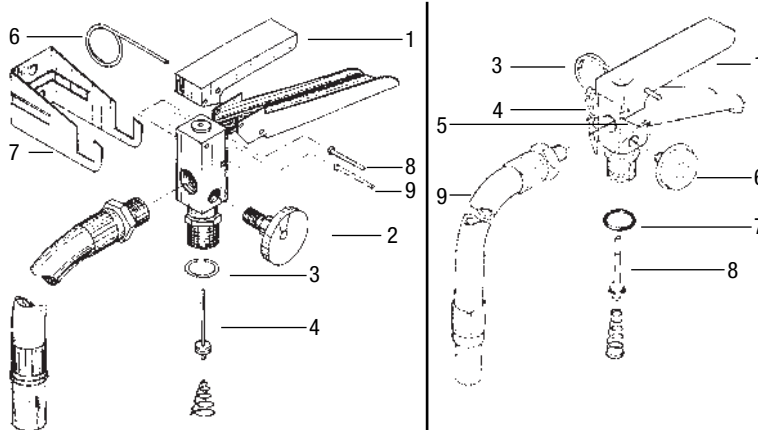


DRY CHEMICAL

ABC 20P-5 PDC 20P-4 K 20P-2 ABC 10P-5 PDC 10P-4

FIG.	PART#	DESCRIPTION
2	G195	Gauge (P13069)
3	OR115	O-Ring (12301) Pyrene Type
4	PVS2	Valve Stem c/w O-Ring (12141) Pyrene Type
6	SPP	Safety Pin (P10002)
7	P50	Wall Hook (10 lb.) (13352) Pyrene Type
7	P60	Wall Hook (20 lb.) (13358) Pyrene Type
8	RV81	Lever Rivet (13526)
N/S	RA20	Recharge Adapter

EXTINGUISHER PICTOGRAMS - PYRENE/CHUBB



DRY CHEMICAL

PDC 10 P-3 PDC 20 P-3 ABC 10 P-3 ABC 20 P-3

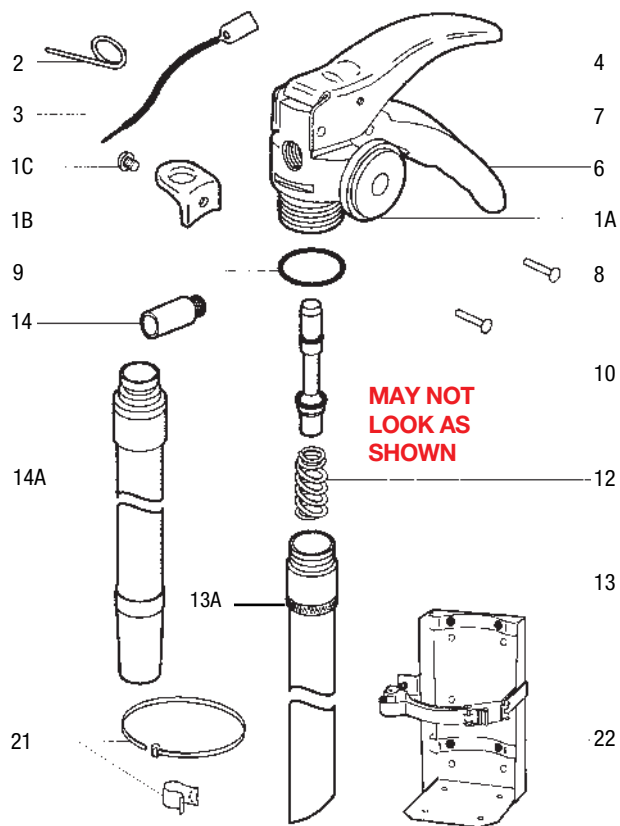
FIG.	PART#	DESCRIPTION
3	SPP	Safety Pin (P10002)
N/S	P50	Wall Hook (10 lb.) (13352) Pyrene Type
4	RV87	Lever Rivet (12158) Pyrene Type
6	G195	Gauge
7	OR115	O-Ring (12301) Pyrene Type
8	PVS2	Valve Stem c/w O-Ring (12141) Pyrene Type
9	PHA74	Hose Assembly (ABC 10 P-3) Includes Nozzel (13774) Pyrene Chubb Type

Discontinued

FIG.	PART#	DESCRIPTION
9	PHA76	Hose Assembly (PDC 10 P-3) Includes Nozzel (13076) Pyrene Chubb Type
9	PHA02	Hose Assembly (ABC 20) (20 LB. BC) Includes Nozzel (13775) Pyrene Type
N/S	RA20	Recharge Adapter

Discontinued

Discontinued



**DRY CHEMICAL - 2½ - 5 LB
ABC MODELS**

70358 70384 70385 70606 468124-002

BC MODELS

24220 74217

FIG.	PART#	DESCRIPTION
1A	P366698	Valve Body
1B	B8516	Hanger Loop
1C	B19622	Hanger Loop Screw
2	SPP	Pull Pin
3	TS	Tamper Seal
4	P300592K	Lever
6	G195	Gauge - 195 psi
7	P300558K	Handle
8	B18404	Handle Rivet
9	OR212	(Valve Body) Collar O-Ring
10	P440068K	Valve Stem - 1 3/8" Long
12	K320732	Spring
13	P322024K	Syphon Tube 5 lb (Requires Coupling Collar)
13	P320701	Syphon Tube 2 1/2 lb (Requires Coupling Collar)
13A	P342081	Coupling Collar
14	P320337K	Nozzle - 2 1/2 lb ABC
14A	P440089	Hose & Nozzle Assembly - 5 lb ABC

Discontinued

Discontinued

**DRY CHEMICAL 10 - 20 LB
ABC MODELS**

70607 70609

BC MODELS

24223 24226

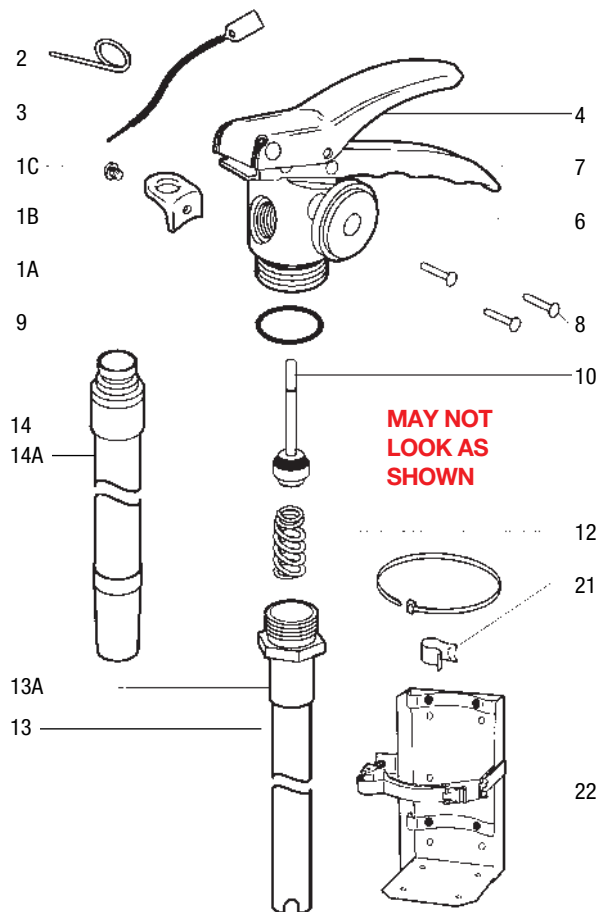


FIG.	PART#	DESCRIPTION
1A	P366698	Valve Body
1B	B8516	Hanger Loop
1C	B19622	Hanger Loop Screw
2	SPP	Pull Pin
3	TS	Tamper Seal
4	P300592K	Lever
6	G195	Gauge - 195 psi
7	P300558K	Handle
8	B18404	Handle Rivet
9	OR212	(Valve Body) Collar O-Ring
10	P440068K	Valve Stem - 1 3/8" Long
12	K320732	Spring
13	P322025	Syphon Tube - 10 lb (Requires Coupling Collar)
13	B21007864	Syphon Tube - 20 lb (Requires Coupling Collar)
13A	P342081	Coupling Collar - 10 lb
13A	B21007864	Complete Syphon Tube
14	P422000	Hose & Nozzle Assembly - 10 lb ABC
14	P440330	Hose & Nozzle Assembly - 20 lb ABC

Discontinued

Discontinued

Dry Chemical - 2½ - 5 LB Accessories

FIG.	PART#	DESCRIPTION
21	A14776	Universal Hose Strap (use part #A14776)
N/S	WH5	Wall Hanger
22	VB5	Heavy-Duty Vehicle Bracket - 5MP
N/S	RA16	Recharge Adapter
N/S	HTA45	Hydrostatic Test Adapter (12290)

Dry Chemical - 10 - 20 LB Accessories

FIG.	PART#	DESCRIPTION
21	A14776	Universal Hose Strap (use part #A14776)
N/S	WH5	Wall Hanger - 10MP
N/S	WH20	Wall Hanger - 20MP
22	VB5	Heavy-Duty Vehicle Bracket - 10MP
22	VB7	Heavy-Duty Vehicle Bracket - 20MP
N/S	RA11	Recharge Adapter
N/S	HTA44	Hydrostatic Test Adapter (9860)

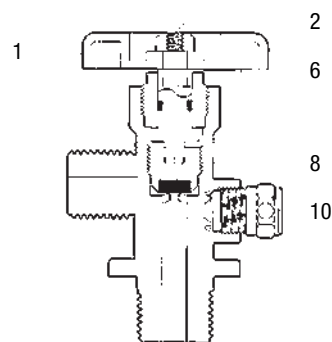
2½ - 20 LB Dry Chemical Accessories

FIG.	PART#	DESCRIPTION
21	UHS34/UHC	Universal Hose Strap/Clip
22	VB4	Heavy Duty Vehicle Bracket - 5 lb
22	VB5	Heavy Duty Vehicle Bracket - 10 lb
22	VB7	Heavy Duty Vehicle Bracket - 20 lb
N/S	WH5	Wall Hanger – Up to 5 lb
N/S	WH10	Wall Hanger – Up to 10 lb
N/S	WH20	Wall Hanger – Up to 20 lb
N/S	RA20	Recharge Adapter
N/S	HTA43	Hydrostatic Test Adapter

Sherwood Carbon Dioxide & Nitrogen Commercial Valve Accessories

FIG.	PART#	DESCRIPTION
1	A1919GV	Hand Wheel, Aluminum
1	L1919GV	Hand Wheel, Plastic
2	1251GV	Hand Wheel Nut
6	30101GV	Bonnet & Operating Stem Assembly
8	140040AGV	Lower Stem & Seat Insert Assembly, Carbon Dioxide
10	928GV	Safety Plug, Disc & Gasket Carbon Dioxide (for DOT 1800 cylinders)
10	932GV	Safety Plug, Disc & Gasket Nitrogen (for DOT 2015 cylinders)
N/S	QR39	Collar O-Ring for GV Valves with straight threads for aluminum cylinders

**SHERWOOD CARBON DIOXIDE & NITROGEN
COMMERCIAL VALVES
GV SERIES "GLOBAL" INDUSTRIAL VALVES**



"GLOBAL" SERIES



2½ - 20 LB DRY CHEMICAL

- PC2.5VBABC-1 – 2½ LB ABC PC10HABC-1 – 10 LB ABC PC20BC-1 – 20 LB BC
- PC5ABC-1 – 5 LB ABC PC10TABC-1 – 10 LB ABC PC5PK-1 – 5 LB PK
- PC5VBABC-1 – 5 LB ABC PC20ABC+1 – 20 LB ABC PC10PK-1 – 10 LB PK
- PC5ABC+1 – 5 LB ABC PC5BC-1 – 5 LB BC PC20PK-1 – 20 LB PK
- PC5VBABC+1 – 5 LB ABC PC10BC-1 – 10 LB BC

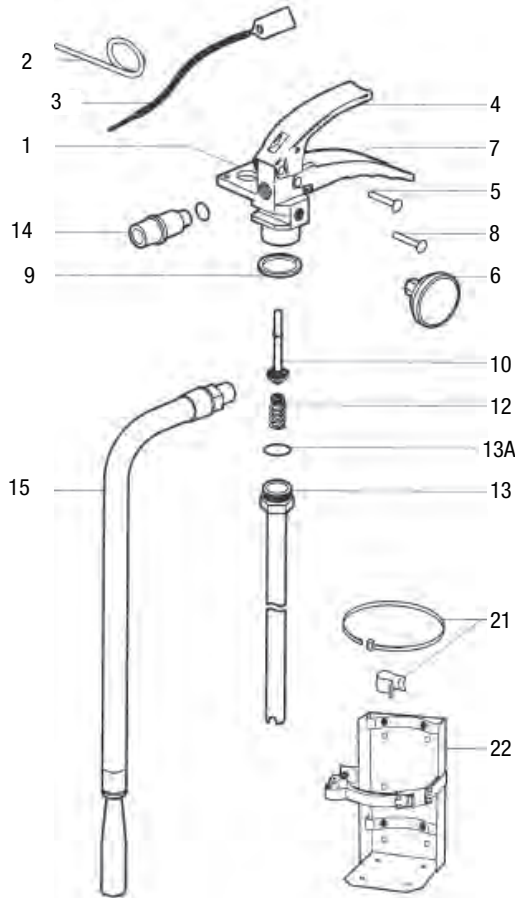
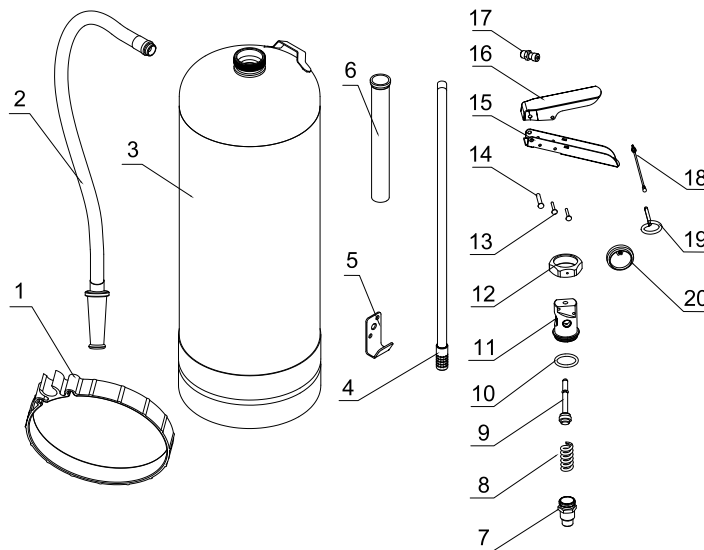


FIG.	PART#	DESCRIPTION
1	AS436890	Valve Assembly – 2½ lb PC ABC
1	AS429084	Valve Assembly – 5 LB. PC ABC, BC, PK
1	AS429086	Valve Assembly – 10 lb PC10TABC-1
1	AS429085	Valve Assembly – 10 lb PC10HABC-1, 10 lb BC & PK
1	AS429087	Valve Assembly – 20 lb, ABC, BC & PK
2	SPP	Pull Pin
3	TS	Tamper Seal
4	AS429096	Lever
5	AS428130	Lever Rivet
6	AS56776	Gauge – 195 PSI – All Dry Chemical
7	AS429097	Handle
8	AS428130	Handle Rivet
9	AS428327	Collar Quad Ring
10	AS429099	Valve Stem Assembly
12	F415565	Spring
13	AS428795	Syphon Tube – 2½ lb
13	AS428796	Syphon Tube – ALL 5 lb
13	AS428798	Syphon Tube – 10 lb - PC10TABC-1
13	AS428797	Syphon Tube – All 10 lb except PC10TABC-1
13	AS428799	Syphon Tube – ALL 20 lb
13A	AS76076	Syphon Tube O-Ring
14	AS428269	Nozzle – 2½ lb
15	AS428729	Hose and Nozzle Assembly, PCABC+1, PCVBABC-1
15	AS428730	Hose and Nozzle Assembly, 5 lb PK
15	AS428728	Hose and Nozzle Assembly, PCABC-1, PCVBABC-1
15	AS428731	Hose and Nozzle Assembly, 5 lb BC
15	AS428732	Hose and Nozzle Assembly, ABC & BC
15	AS428734	Hose and Nozzle Assembly, 10 lb PK
15	AS428736	Hose and Nozzle Assembly, 20 lb ABC
15	AS428738	Hose and Nozzle Assembly, 20 lb PK
15	AS428740	Hose and Nozzle Assembly, 20 lb BC



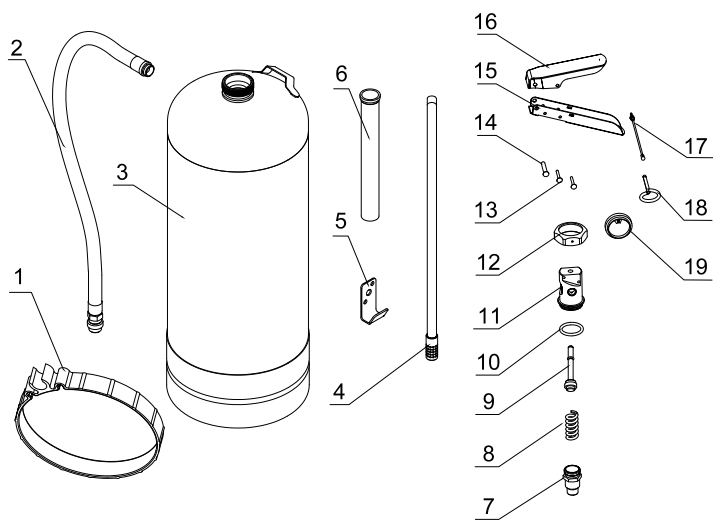
WATER 2.4 GALLON (9L)
UL/ULC RATING: 2A
MODELS: SF-PW250 (UL) & WBDL-PW250 (ULC)

FIG.	PART#	DESCRIPTION
1	C160400	Hose Band
2	W162690	Hose Assembly
4	W163700	Siphon Tube Assembly
5	W160600	Wall Hook
6	W163650	Fill Tube, White, PW
7	W163605	Brass String Retainer
8	W161630	Spring
9	C161628	Valve Stem Assembly
10	W161645	Valve Body O-ring
11	-	Valve Body
12	-	Valve Body Collar Hex Nut
13	W162603	Carry Handle Rivet (2 required)
14	W162603	Top Lever Rivet
15	W160695	Carry Handle
16	W160614	Top Lever
17	W162695	Schrader Valve
18	VBT	Pull Pin Retaining Strip
19	C951236	Large Pull Pin
20	OFG100	Wet Chem. Gauge - 100PSI



WET CHEMICAL (6L)
UL/ULC RATING: 1A : K
MODELS: SF-6LK (UL) & WBDL-6LK (ULC)

FIG.	PART#	DESCRIPTION
1	C160400	Hose Band
2	W162680	Wet Chem. Hose Assembly (Incl. Nozzle)
4	W163600	Siphon Tube Assembly
5	W160600	Wall Hook
6	W163651	Fill Tube, Black, K Class
7	W163605	Brass String Retainer
8	W161630	Spring
9	C161628	Valve Stem Assembly
10	W161645	Valve Body O-ring
11	-	Valve Body
12	-	Valve Body Collar Hex Nut
13	W162603	Carry Handle Rivet (2 required)
14	W162603	Top Lever Rivet
15	W160695	Carry Handle
16	W160614	Top Lever
17	VBT	Pull Pin Retaining Strip
18	C951236	Large Pull Pin
19	OFG100	Wet Chem. Gauge - 100PSI
20	W31161	Wet Chem Valve Assembly - Complete
21	SF6LK	Wet Chem Recharge Concentrate (3L) - Not Shown



STRIKE FIRST 5-10-15-20 LB CO₂S

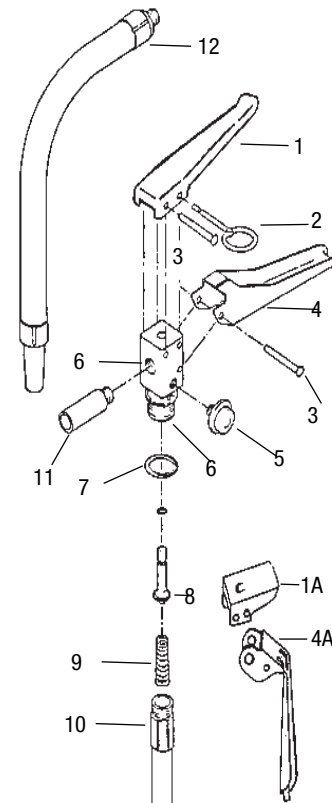
FIG.	PART#	DESCRIPTION
2	SF31132	Stem Assembly, 5-10-15-20 lb Models (Pre '05)
2	SF31133	Stem Assembly, 5-10-15-20 lb Models (Present)
3	SF31142	Spring, 5-10-15-20 lb Models
4	SF31143	Spring Retainer Nut, 5-10-15-20 lb Models
5		Washer (Included with SF31143)
6	SF31145	Safety Cap Assembly, 5-10-15-20 lb Models
7		Washer (Included with SF31145)
8		Disk (Included with SF31145)
9	SF31138	Top Lever Rivet (Stainless Steel) All Models
10	SF31152	Top Lever (Stainless Steel) All Models
11	SF31153	Pull Pin (Stainless Steel) All Models
12	SF31135	Chain (Stainless Steel) All Models
13	SF31148	Carry Handle (Stainless Steel) All Models
14	SF31148A	Carry Handle Nut & Bolt (Stainless Steel) All Models
N/S	SF31146	Elbow, 10-15-20 lb Models
18	SF20217	O-Ring - Valve Body, All Models
16	SF31131	Swivel Tube Assembly, 5 lb Model
17	SF11309	Horn, 5 lb CO ₂
17	SF21251	Horn, 10 lb CO ₂
17	SF21271	Horn, 15 lb & 20 lb CO ₂
N/S	SF21273	Horn Diffuser Lock Nut
N/S	10SYP	Siphon Tube - 10 lb Model
N/S	15SYP	Siphon Tube - 15 & 20 lb Models
N/S	361	Hose 3/4" F x 1/4" M
N/S	RH6	Rubber Grip
N/S	ESN7	CO ₂ Horn 6" Discharge Pipe Nipple
N/S	CH10	Horn, 10 lb Model
N/S	CH15	Horn, 15 & 20 lb Models

**STRIKE FIRST DRY CHEMICAL
5-30 lb DRY CHEMICAL LARGE VALVE 1.125"**

5 lb 310ABC / 10 BC 5 lb 340 ABC 10 lb ABC / BC
20 lb ABC / BC 30 lb ABC



FIG.	PART#	DESCRIPTION
1	C160413	Top Lever (Strike First) 5, 10 lb (Alum.)
1	C160414	Top Lever (All Diamond, 20 lb Strike First) (Black Steel)
NEW 1	SF160417	Top Lever - All (Stainless Steel)
2	DSP	Pull Pin (Steel) (951236) - All
2	SF755651	Pull Pin (Plastic) - All
3	RV80	Rivet (162803) - All
4	C160394	Carry Handle (Strike First) 5, 10 lb (Alum.)
4	C160395	Carry Handle (Diamond), 5 - 30 lb (Black Steel)
NEW 4	C160398	Carry Handle - All (Stainless Steel)
5	G195	Pressure Gauge - 195 PSI - 5, 30 lb (Diamond 5, 10 LB SF)
5	G235	Pressure Gauge - 235 PSI - 5, 30 lb (Diamond 10, 20 lb D/C)
6	C160688	Valve Body - All
7	OR118	O-Ring (Valve Body) 117 All (161345) Strike & Diamond Type
8	C161428	Valve Stem Assy. New Models-All (Post 87)
9	C161230	Spring - All
10	C163517	Syphon Tube 5 lb (Strike First)
10	C163518	Syphon Tube - Models 310LV, SB5 (Plastic)
10	C163518S	Syphon Tube 5 lb BC, 310LV, ABC (Steel)
10	C163519	Syphon Tube - Models 340LV, 5 lb Diamond (Plastic)
10	C163519S	Syphon Tube 340LV, ABC (Steel)
10	C163531	Syphon Tube 10 lb (Strike First)
10	C163532	Syphon Tube 10 lb (Diamond) (Plastic)
10	C163532S	Syphon Tube 10 lb ABC, BC (Steel)
10	C163549	Syphon Tube 20 lb (Diamond) (Plastic)
10	C163549S	Syphon Tube 20 lb ABC, BC (Steel)
NEW 10	C163550S	Syphon Tube 30 lb ABC (Steel)
11	C160716	Fixed Nozzle - Model SB5, Diamond 5 lb BC
12	C161605	Hose Assembly - Models 310LV (5 lb Diamond) (Strike First)
12	C161606	Hose Assembly - Models 340LV (5 lb Diamond)
12	C162269	Hose Assembly - (Diamond ABC 20 lb)
12	C162270	Hose Assembly - (Diamond ABC 30 lb)
12	C162276	Hose Assembly - (Diamond, SF ABC & BC 10 lb) (BC 20 lb)

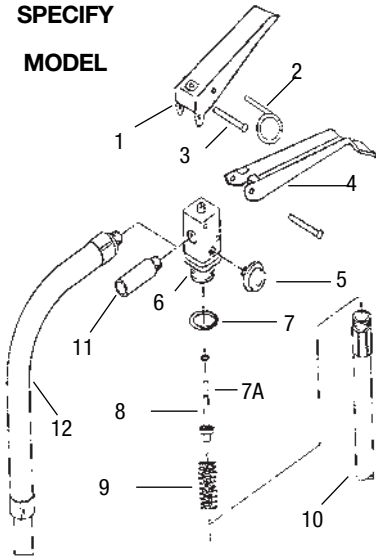


ACCESSORIES

FIG.	PART#	DESCRIPTION
N/S	RA11	Recharge Adapter
N/S	HTABU1	Hydrostatic Test Adapter (5 lb Large Valve, 10-30 lb)
13	C160400	Hose Band - All
N/S	C160738	Diamond Wall Bracket - 5 lb (Diamond & Strike First)
N/S	C160752	Diamond Wall Bracket - 10 lb (Diamond & Strike First)
N/S	C160791	Diamond Wall Bracket - 20 lb (Diamond)
N/S	C160792	Diamond Wall Bracket - 30 lb



**SPECIFY
MODEL**



DIAMOND AND STRIKE FIRST DRY CHEMICAL

2-5 LB SMALL VALVE OR 7/8" OR 1"

2 lb ABC 2.5 lb ABC 2.75 lb BC

4 lb ABC 5 lb 310P / 340P

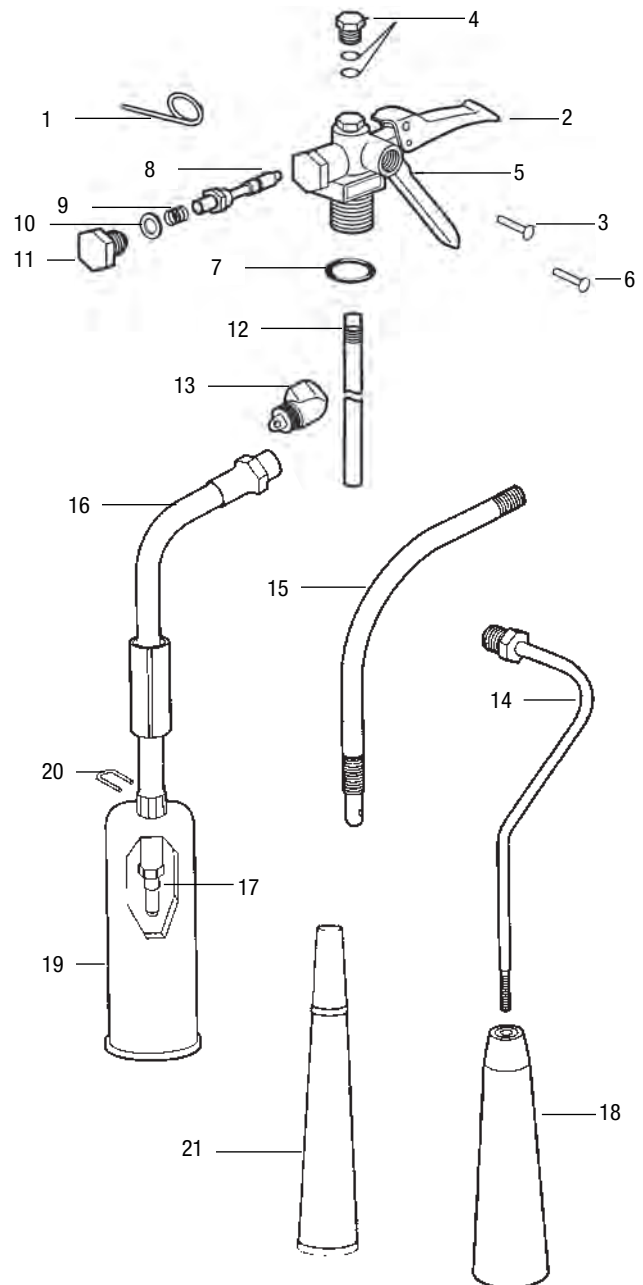
FIG.	PART#	DESCRIPTION
1	C110414	Top Lever (Model 110P, SB2.5)
1	C310415	Top Lever (Model 310P, 340P)
2	DSP	Pull Pin - All
3	C110803	Handle Rivet - All (Pkg of 10)
4	C110396	Handle (Models - All)
5	G150	Pressure Gauge - 150 PSI (110P, SB2.5)
5	G195	Pressure Gauge - 195 PSI - (310P, 340P)
6	C110688	Valve Body - All
7	C110345	O-Ring (Valve Body) .115 - All
7A	OR9025	O-Ring (Valve Stem) 902-.5 - All
8	C110427	Valve Stem Assembly - All
9	C110230	Spring - All
10	C110947	Syphon Tube Assembly (Model 110P, SB2.5)
10	C163497	Syphon Tube 2½ lb (Old Style)
10	C110948A	Syphon Tube - ABC110, SB275, WBDL275 (Steel)
10	C310517	Syphon Tube Assembly (Model 310P)
10	C340518	Syphon Tube Assembly (Model 340P)
11	C110999	Fixed Nozzle (Model 110P, SB2.5)
12	C310605	Hose Assembly (Model 310P)
12	C340605	Hose Assembly (Model 340P)

ACCESSORIES

FIG.	PART#	DESCRIPTION
N/S	P90	Wall Brackets (Models 310P, 340P)
N/S	C160700	Wall Brackets (Models 110P, SB2.5P)
N/S	HTASF2	Hydrostatic Test Adapter (2-4 lb, 5 lb Small Valve)

CARBON DIOXIDE FIRE EXTINGUISHER VALVES
DIAMOND, ANSUL, RS MODELS WITH RS VALVE
(PSH 5 - 20 LB)

FIG.	PART#	DESCRIPTION
1	SPP	Pull Pin, Stainless Steel - RS, Superior Fyr-Fyter, Diamond
2	RS0102	Lever (P5970-8S) - RS, Superior, Fyr-Fyter, Diamond
3	RV63	Lever Rivet - RS, Superior, Fyr-Fyter, Diamond
4	RS5	Safety Disc, Washer & Nut Assembly RS, Fyr-Fyter, Diamond
5	RS0104	Handle (P6037-12SS) RS, Superior, Fyr-Fyter, Diamond
6	RV81	Handle Rivet (P6037-4SPS) - RS, Superior, Fyr-Fyter, Diamond
7	OR216A	Collar O-Ring - RS PSH-A & PSH-5AL
N/S	RS0108	Valve Stem (P5970-21SB) RS, Superior, Fyr-Fyter, Diamond
8	FVS17	Valve Stem (60456) Fyr-Fyter
9	RS0109	Spring
10	RS0110	Copper Seal, Lead Coated - RS
11	RS0111	Nut Plug
12	5SYP	12 $\frac{5}{8}$ " Syphon Tube - 2H - 5 lbs
12	10SYP	14 $\frac{1}{2}$ " Syphon Tube - 10 lbs
12	15SYP	21 $\frac{1}{8}$ " Syphon Tube - 15 - 20 lbs
13	ELB25	$\frac{1}{4}$ " Elbow & Diffuser - All 10 - 20 lbs
13	ELB37	$\frac{3}{8}$ " Elbow & Diffuser - All 10 - 20 lbs.
14	SW50	Swivel Discharge Assembly - RS, Superior, Diamond - 5 lbs
15	SWT2	Discharge Tube
16	361	Hose for 10 - 15 - 20 lb CO2 ($\frac{1}{4}$ " F x $\frac{1}{4}$ " F)
16	362	36" Hose for 10 - 15 - 20 lb CO2 ($\frac{1}{4}$ " F x $\frac{3}{8}$ " F)
17	RDD	Nozzle Diffuser All 10 - 15 - 20 lb
18	CH5D	Horn - 5 lb. w/Diffuser in Discharge Tube
19	RDH10	Horn with Handle - 10 lb
19	RDH15	Horn with Handle - 15 - 20 lb
20	RDC	U-Pin 10 - 15 lb
21	CH10	Horn Conical
21	CH15	Horn Conical



Discontinued

NEW PRODUCT LISTING TO HELP GROW YOUR BUSINESS

Fireboy NOVEC 1230 (pg 7)

FireTech FES3 Portable Fire Extinguisher Stand (Pg 41)

12-Gauge Steel Heavy Duty Fire Safety Plan Box (Pg 50)

Sprinkler Gauge Installation Labels (Pg 66)

Mircom FA-100 Series 3 and 6 Zone Conventional Panels (Pg 88)

Kidde FX Series 5 and 10 Zone Conventional Panels English and French (Pg 88, 89)

MIR-65 Series Smoke Detector Kits (Pg 90)

Mircom FX-350 Series Intelligent Panels (Pg 90)

Kidde FX Series Intelligent Panels (Pg 91)

Booster Power Supply (Pg 92)

FX-350, FA-1000 Graphic Annunciation Modules (Pg 93)

RA-200 Mircom Annunciators (Pg 94)

Kidde FX Conventional Series Annunciators (Pg 94,95)

Mircom Manual Pull Stations Series MS-400 / 700 / 700U (Pg 96)

Mircom SD Series Smoke and Heat Combo Detectors (Pg 97)

InnovairFlex Duct Detection (Pg 98)

SuperDuct Duct Detection (Pg 98)

Mircom MIX-3000 Series Intelligent Smoke and Heat Detectors (Pg 99)

Kidde KIR Series Intelligent Smoke and Heat Detectors (Pg 99)

Intelligent Duct Detectors (Pg 100)

Intelligent Input/Output Modules (Pg 100, 101)

Intelligent Pull Stations, Mircom, Kidde, EST (Pg 101)

New Mircom 400 Series Horns, Strobes and Horn Strobes (Pg 102)

New Edwards MB Series Bells (Pg 103)

Replacement Mother Boards (Pg 104)

Smoke Alarms - New 10 Year, Battery Operated, Hardwired, Wireless (Pg 108-110)

Carbon Monoxide Alarms - New Battery Operated, Plug-In AC (Pg 110-111)

Smoke/CO Combination Alarms - New 10 Year, Battery Operated, Hardwired, Wireless (Pg 112-114)

Alarm Relay Modules & Alarm Adaptors (Pg 115)

Blowout 10 oz Detector Duster (Pg 121)

SOLO808 12ft Smoke and CO Test Starter Kit (Pg 123)

AIMP4000 Series Running Man Photoluminescent Signs (Pg 129, 154)

EBN Deluge Series Wet Location Battery Unit (Pg 132)

RMN Deluge Series Wet Location Remote Heads (Pg 133)

CRPN Deluge Series Wet Location Combo Unit (Pg 135)

RPN Deluge Series Wet Location EXIT Sign (Pg 136)

Flame Series Dated Tamper Seals (Pg 165)

Digital 99 lbs. x 10 oz. Hanging Scale (Pg 168)

Magnetic Hose Retainer (Pg 193)

Stainless Steel "Hair Pin" Clip for "VB" Heavy Duty Brackets (Pg 195)

One-Piece Safety Disc, Washer and Nut Assmely for N100 and N200QR Valves (Pg 190)

2" Tube and 1/8" Tube/Wire Compression Seal (Pg 268)

Quick Patch for Corner Pulleys (Pg 269)

Blind Compression and Quick Seal (Pg 269)

7' (84") #304 Stainless Steel Pipe (Pg 270)

7' (84") Black Pipe (Pg 271)

- **RESTAURANT SYSTEM PARTS**



GAS VALVES AND ACCESSORIES

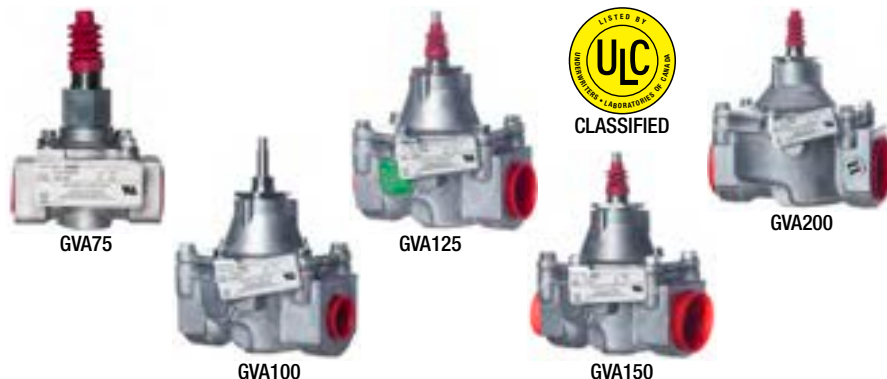
ASCO Gas Valves

ASCO MECHANICAL GAS VALVES are U.L.C. Classified for use in RANGE GUARD, PYROCHEM and KIDDE fire systems per NFPA 17 & 17A. The largest size available is 3".

Note: For Kidde also use KCB, see page 259.

PART#	DESCRIPTION
GVA75	¾" Mechanical Gas Valve
GVA100	1" Mechanical Gas Valve
GVA125	1¼" Mechanical Gas Valve
GVA150	1½" Mechanical Gas Valve
GVA200	2" Mechanical Gas Valve
GVA250*	2½" Mechanical Gas Valve
GVA300*	3" Mechanical Gas Valve

*Special Order



ASCO ELECTRICAL GAS VALVES are U.L.C. CLASSIFIED & CSA APPROVED for use in all systems. Note: All valves (except GVS75) must be mounted with the solenoid vertical and upright. The largest size available is 3".

PART#	DESCRIPTION
GVS75	¾" 110 VAC Electric Gas Valve
GVS100	1" 110 VAC Electric Gas Valve
GVS125	1¼" 110 VAC Electric Gas Valve
GVS150	1½" 110 VAC Electric Gas Valve
GVS200	2" 110 VAC Electric Gas Valve
GVS250*	2½" 110 VAC Electric Gas Valve
GVS300*	3" 110 VAC Electric Gas Valve

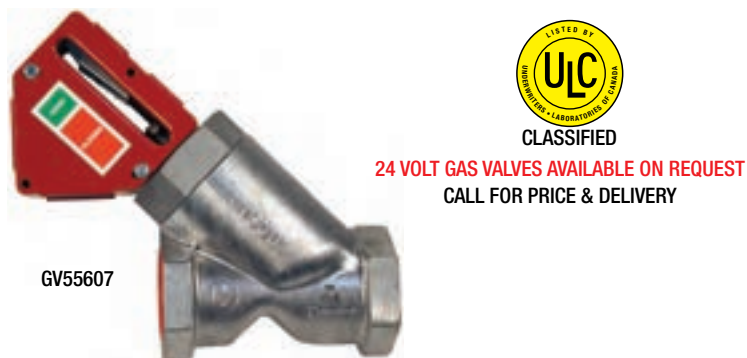
*Special Order



Ansul Gas Valves

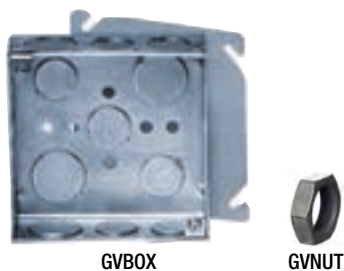
ANSUL MECHANICAL GAS VALVES are U.L.C. listed for use in ANSUL SYSTEMS per NFPA 17 & 17A. The largest size available is 3". **Complete with Piston Kit Assembly.**

PART#	DESCRIPTION
GVB55598	Gas Valve, Mechanical, ¾" ANSUL
GVB55601	Gas Valve, Mechanical, 1" ANSUL
GVB55604	Gas Valve, Mechanical, 1¼" ANSUL
GVB55607	Gas Valve, Mechanical, 1½" ANSUL
GVB55610	Gas Valve, Mechanical, 2" ANSUL
GVB25937	Gas Valve, Mechanical, 2½" ANSUL
GVB25938	Gas Valve, Mechanical, 3" ANSUL
15733AS	Air Cylinder and Tubing (for mechanical gas valves)
416018AS	Cocking Lever, Mechanical Gas Valve



BOX FOR GVA gas valve.

PART#	DESCRIPTION
GVBOX	Box and Cover for GVA Valve
GVNUT	Special Nut for fastening GVBOX to GVA Valve



UNIVERSAL GAS VALVE KIT fits all GVA gas valves, with release-to-close and trip-to-close options.

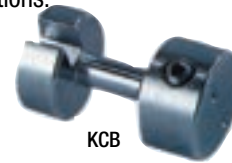
PART#	DESCRIPTION
GVK	Box and Cover for GVA Valve



GVK

KIDDE GAS VALVE CABLE BLOCK to be used with GVA valve on kidde systems. Complete with instructions.

PART#	DESCRIPTION
KCB	Kidde Cable Block for use with GVA Valve



KCB

ANSUL GENERIC PNEUMATIC PISTON for actuation of a mechanical gas valve. This item U.L. Classified to be used in ANSUL systems per NFPA 17 & 17A and the manufacturers installation instructions.

PART#	DESCRIPTION
PKA	Ansul GENERIC Style Pneumatic Piston Kit
PKAKIT	Replacement PKA Hardware Only



PKA

CHANNELLOCK® LOCKNUT PLIERS are designed for quick, easy adjustment of electrical locknuts. Fits locknut sizes: 1/2", 3/4", 1", 1 1/4", and 1 1/2". The thin profile is ideal for use in tight/wire-confined electrical boxes. Spring-loaded handles lock for easy storage and the handle shape allows for both right- and left-handed use.

PART#	DESCRIPTION
TL960	Locknut Pliers



TL960

MANUAL PULL STATION GUARDS

Compatible with **Ansul®** or older **Kidde** remotes, this **SURFACE-MOUNT ROUND REMOTE PULL GUARD** reduces false discharges of fire systems from accidental snagging of manual remote pulls on clothing, food carts, etc. Measures 2 3/4" D x 4 5/8" Dia.

PART#	DESCRIPTION
PG1	4 5/8" dia. Surface-Mount Remote Pull Guard



PG1

Compatible with **Ansul®** remotes, this **RECESSED ROUND REMOTE PULL GUARD** reduces false discharges of fire systems from accidental snagging of manual remote pulls on clothing, food carts, etc. Measures 1 1/2" D x 4 1/4" Dia.

PART#	DESCRIPTION
PG2	4 1/4" dia. Recessed Remote Pull Guard



PG2

This **SURFACE-MOUNT REMOTE PULL GUARD** works with **Pyro-Chem®**, **Range Guard®**, **Kidde**, **Amerex®**, or **Buckeye** remotes, reducing false discharges of fire systems from accidental snagging of manual remote pulls on clothing, food carts, etc. Measures 5 5/16" H x 4 5/16" W x 3" D.

PART#	DESCRIPTION
PG3	4 5/16" dia. Surface-Mount Remote Pull Guard



PG3

This **SURFACE-MOUNT ROUND REMOTE PULL GUARD** is compatible with **Amerex®** or **Ansul®** remotes and reduces false discharges of fire systems from accidental snagging of manual remote pulls on clothing, food carts, etc. Measures 2 5/8" D x 6" Dia. CO2

PART#	DESCRIPTION
PG4	6" dia. Surface-Mount Round Remote Pull Guard

MICROSWITCHES

U.L.C. LISTED **ANSUL MICROSWITCHES** complete with wiring harness and hardware.

PART#	DESCRIPTION
423878AS	SPDT Microswitch, Ansul
423879AS	DPDT Microswitch, Ansul
423880AS	3PDT Microswitch, Ansul
423881AS	4PDT Microswitch, Ansul
428311AS	Alarm Initiating Microswitch, SPDT, Ansul



U.L. Classified **ANSUL STYLE MICROSWITCHES** complete with wiring harness and hardware.

PART#	DESCRIPTION
MIC1	SPDT Microswitch, Generic, UL Classified
MIC2	DPDT Microswitch, Generic, UL Classified



U.L. Classified **RANGE GUARD STYLE MICROSWITCHES** for the mechanical control head complete with wiring harness and hardware.

PART#	DESCRIPTION
MIC4	Range-Guard Style SPDT Microswitch
MIC5	Range-Guard Style DPDT Microswitch



U.L. Classified **RANGE GUARD STYLE MICROSWITCHES** for the "A+" **SERIES** mechanical control head complete with wiring harness and hardware.

PART#	DESCRIPTION
MIC6	Range Guard® & Kidde-Style SPDT "A+", KRS-50, Series Microswitch
MIC7	Range Guard® & Kidde-Style DPDT "A+", KRS-50, Series Microswitch



RESET RELAYS AND CONTACTORS

Our **RESET RELAY** is CSA approved and U.L. Listed and required when using an electrical gas valve. Wiring diagrams, permanently attached to the inside cover, offer easy reference. Complete wiring and installation instructions are also included. Must be installed in accordance with system manufacturer's instructions (not included). Contacts are rated at 10 A.

PART#	DESCRIPTION
SRR	Reset Relay (110 VAC)
SRR24D	Reset Relay (24 VDC)



ELECTRICAL CONTACTORS manufactured by FURNAS ULC & CSA Recognized Component.

2 POLE CONTACTORS		
PART#	DESCRIPTION	MFG PART#
C2P30	30 AMP 110 Volt Coil	41NB20AF
C2P40	40 AMP 110 Volt Coil	42BF15AF106
C2P50	50 AMP 110 Volt Coil	42CF15AF106
C2P63	63 AMP 110 Volt Coil	42DF15AF106
C2P75	75 AMP 110 Volt Coil	42EF15AF106
C2P120	120 AMP 110 Volt Coil	42HF15AF
C2P150	150 AMP 110 Volt Coil	42IF15AF

3 POLE CONTACTORS		
PART#	DESCRIPTION	MFG PART#
C3P30	30 AMP 110 Volt Coil	41NB30AF
C3P40	40 AMP 110 Volt Coil	42BF35AF
C3P50	50 AMP 110 Volt Coil	42CF35AF
C3P63	63 AMP 110 Volt Coil	42DF35AF
C3P75	75 AMP 110 Volt Coil	42EF35AF
C3P120	120 AMP 110 Volt Coil	42HF35AF
C3P150	150 AMP 110 Volt Coil	42IF35AF

CONTACTOR ENCLOSURES		
PART#	DESCRIPTION	SIZE
CHK0664	30 / 60 AMP	6 $\frac{5}{8}$ " x W 6 $\frac{3}{8}$ " x D 4"
CHK0884	75 / 90 AMP	H 8 $\frac{1}{2}$ " x W 8" x D 4"



FURNAS ELECTRICAL CONTACTORS

STAINLESS STEEL CABLE, CRIMPS AND S-HOOKS

STAINLESS STEEL CABLE for automatic suppression systems. Aircraft Type 7" x 7" cable with a minimum break strength of 480 lbs. Stranded the same as Mil-W-83420.

PART#	DESCRIPTION
1000C16	1000 ft. of 1/16" Stainless Steel Cable
500C16	500 ft. of 1/16" Stainless Steel Cable
250C16	250 ft. of 1/16" Stainless Steel Cable
250C64	250 ft. of 3/64" Stainless Steel Cable



500C16

S-HOOKS and **CRIMPS** for automatic suppression systems.

PART#	DESCRIPTION	QTY.
SHK	1" S-Hooks	100
OS1	3/64" Oval Zinc Plated Copper Crimp	100
OS2	1/16" Oval Zinc Plated Copper Crimp	100
OS3	1/16" Copper Stop Crimp	100
OS4	1/16" Kidde Style Copper Crimp	100
BHN	Brass Hex Nut	



SHK

OS3

OS1, OS2

OS4

BHN

We are in the business of growing your business

TOOLS

THIS CABLE CUTTER produces clean square cuts on stainless steel cable. Cadmium plated to assure maximum rust prevention. Heat treated alloy for long life of cutting edge.

DO NOT USE ON S-HOOKS OR LINKS

PART#	DESCRIPTION
CC093	6" Cable Cutter



CC093

These **CRIMPING TOOLS** have thick comfortable "T" shaped vinyl handles and are made of aircraft quality alloy steel.

PART#	DESCRIPTION
ST116	8" Crimping Tool for 1/16" Copper Oval & Stop Sleeves
ST364	8" Crimping Tool for 3/64" Copper Oval & Stop Sleeves



ST364, ST116

HEAVY DUTY TUBING CUTTER comes with a hardened steel reamer, spare cutter wheel and a lifetime warranty.

PART#	DESCRIPTION
1000TC	Tubing Cutter
*TCB	Extra Cutting Blade for Tubing Cutter (PKG OF 2)



1000TC

COBALT DRILL BITS are made of 8% Cobalt HSS and designed for heavy duty drilling in stainless steel.

PART#	DESCRIPTION
40324DB	3/8" Cobalt Drill Bit
41327DB	Cobalt Drill Bit for #10 Sheet Metal Screw



COBALT DRILL BITS

25" TELESCOPIC MATCH EXTENDER LIGHTS those hard to reach pilot lights with ease. Compresses to pen size and comes with a pocket pen clip. A must for every system service person.

PART#	DESCRIPTION
ME25	25" Telescopic Match Extender



ME25

WD-40

- Stops Squeaks
- Frees Sticky Mechanisms
- Loosens Rusted Parts
- Protects Metal

PART#	DESCRIPTION
WD1011	WD-40 - 11 oz. Aerosol Can
WD10	WD-40 - 3.785 Litre Can



WD1011



WD10

HANDCARE CLEANER is specifically formulated to gently remove a variety of soils and effectively cleanse hands. Hand cleaner is dermatologist-tested.

PART#	DESCRIPTION
G0955	1/2 gal. Orange Pumice Hand Cleaner with Pump Dispenser Medium Soils - Disposable

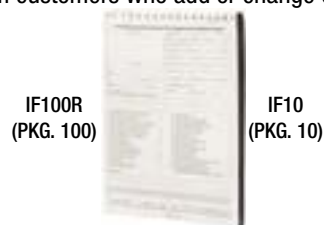


G0955

INSPECTION AND INSTALLATION FORMS

RANGE HOOD INSPECTION 3 part carbonless form. Protect your company from customers who add or change equipment after your service. This form shows the service performed and on what equipment it was performed on.

PART#	DESCRIPTION
IF10	Inspection Form - Package of 10
IF100R	Inspection Form - Package of 100



Look professional. Present your customer with a Certificate of inspection. This elegant certificate measures 8½" x 11" and comes 10 each per package.

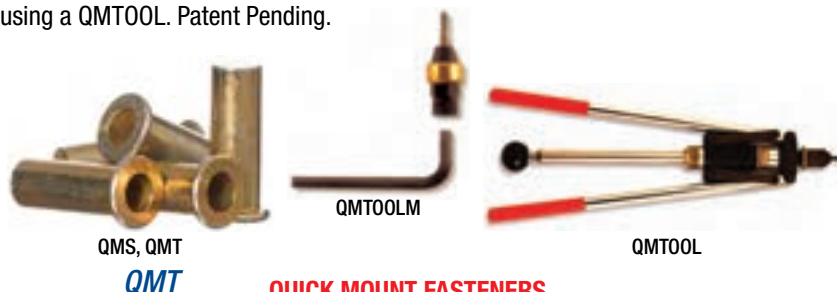
PART#	DESCRIPTION
R510	Certificate of Inspection - Package of 10
100X	Certificate of Inspection - Package of 100



HOOD AND DUCT MOUNT FASTENERS AND TOOLS

BROOKS' QUICK MOUNT FASTENERS for hood penetration requirements. NFPA 96 requires any penetration in the hood exterior to be sealed with a listed device or by a liquid-tight, continuous external weld. The QMT is the **only** UL listed product for mounting hardware in the hood or duct. By using the QUICK MOUNT FASTENERS and SEAL FAST ADAPTERS, you can meet code without the use of welding equipment. Simple three step installation. Drill hole with a QDRILL, insert QMT through the hole, and clinch using a QMTOOL. Patent Pending.

PART#	DESCRIPTION	PKG/QTY
QMT	Quick Mount® Fastener	Pkg. of 10
QMS	¼" - 20 Screw for QMT	Pkg. of 100
QMTOOLM	Wrench Type Installation Tool	
QDRILL*	Quick Mount Drill Bit ⅜"	
QMTOOL	Lever Type Installation Tool	



QUICK MOUNT FASTENERS
THE ONLY LIQUID TIGHT UL LISTED FASTENER

* Not shown

The **EVERGREEN QUIK-FASTENER** (patent pending) gives installers a UL/ULC listed method of fastening items to hoods and plenums in a kitchen ventilation system. The Quik-Fastener combines the thread producing features with a high temperature thread jamming coating. The friction from installing the screw activates the thread jammer to assure the grease tight seal. The package **includes a Double Ended ⅛" Pilot Drill Bit** with a 135 degree split point design for drilling through stainless steel. The **10mm Magnetic Power Driver** is used with most drill motors to drive in the screw into the ⅛" pilot hole.

PART#	DESCRIPTION
1404	Grease-Tite Seal Fasteners, Pkg/24
TL1395	100 mm Magnetic Power Driver For Grease-Tite Fasteners
1399DB	Double Ended 1/8" Pilot Drill Bit



FUSIBLE LINKS

Replacement period as per NFPA 80 Standard for Fire Doors and other Opening Protective, 1 Year after installation.
Every 6 years after for hospitals. Every 4 years after for all other applicants.

GLOBE JS LINKS are specifically designed to standard-type fire dampers and have load range of 3 lbs - 10 lbs. UL listed and are easy to install. Specify length when ordering 2.75", 3.16" and 3.75" by choosing appropriate part number.

2.75" P/N	3.16" P/N	3.75" P/N	DESCRIPTION
321165	320165	321166	165° F Model JS (74° C)
321222	320212	321212	212° F Model JS (100° C)
321281	320280	321280	280° F Model JS (138° C)



GLOBE GS LINKS are designed for the fire damper industry and have load range of 3 lbs - 45 lbs. Variable length with addition of clover hooks. Specify length when ordering 2.75", 3.16" and 3.75" by choosing appropriate part number.

2.75" P/N	3.16" P/N	3.75" P/N	DESCRIPTION
341165	340165	342165	165° F Model JS (74° C)
341212	340212	342212	212° F Model JS (100° C)
341280	340280	342280	280° F Model JS (138° C)
341350	340350	342350	350° F Model JS (177° C)



GLOBE J LINKS are heat activated and made with brass components to resist corrosion. They have a high-strength symmetrical shape with a load range of 3 lbs. - 10 lbs. UL listed.

PART#	DESCRIPTION
G165J	Globe 165° F J Fusible Link



Mechanical heat activated device with a load range of 5 lbs. - 25 lbs with 0.45" mounting holes. Available in 135°, 155°, 165° and 212°.

PART#	DESCRIPTION
G165EA	Globe 165° EA Fusible Link
G212EA	Globe 212° EA Fusible Link NOT FOR SYSTEM USE.



Use **LINKAGE PLIERS** for those systems with linkage-type fusible link bracket assemblies. Makes changing links fast and easy. Simply place the specially curved steel jaws in the bracket holes and squeeze for fast, effortless link replacement. A must for Ansul and Amerex system maintenance personnel.

PART#	DESCRIPTION
TL915	System Linkage Pliers, Locking
TL910	System Linkage Pliers, Non-Locking



GLOBE model D FUSIBLE LINK is U.L. Listed and rated for 1 - 8 lb. load. NOT FOR SYSTEM USE. Special Order.

PART#	DESCRIPTION
FLG165D*	Globe 165° D Fusible Link

*Special Order



GLOBE TEST LINK used for testing out a system without destroying a more expensive fusible link. Sold in packages of 10 each. Same size as the Globe model ML link.

PART#	DESCRIPTION
TLINK	Test Link - Package of 10



TLINK

ELSIE model A FUSIBLE LINK is U.L. Listed and rated for 1 -30 lbs. load. NOT FOR SYSTEM USE.

PART#	DESCRIPTION
E165A	Elsie 165° Fusible Link



E165A

GLOBE ML® FUSIBLE LINKS are U.L. Listed and U.L. Classified for use with extinguishing systems as specified in the installation instructions. Good for 10 - 40 lbs. load. Add 2 Digit date code when ordering. Example FLG360ML-19.

PART#	DESCRIPTION
FLG135ML	Globe 135° ML Fusible Link
FLG165ML	Globe 165° ML Fusible Link
FLG212ML	Globe 212° ML Fusible Link
FLG280ML	Globe 280° ML Fusible Link
FLG360ML	Globe 360° ML Fusible Link
FLG450ML	Globe 450° ML Fusible Link
FLG500ML	Globe 500° ML Fusible Link



ML® FUSIBLE LINK
10 - 40 LB. Load
For: Ansul, Kidde
Pyro Chem

GLOBE A FUSIBLE LINKS are U.L. Listed and U.L. Classified for use with extinguishing systems as specified in the installation instructions. Good for 3 - 45 lbs. load. Add 2 Digit date code when ordering. Example FLG360A-19.

PART#	DESCRIPTION
FLG165A	Globe 165° A Fusible Link
FLG212A	Globe 212° A Fusible Link
FLG280A	Globe 280° A Fusible Link
FLG360A	Globe 360° A Fusible Link
FLG450A	Globe 450° A Fusible Link



GLOBE A LINK
3 - 45 LB. Load
For: Range Guard
(FLG360A Only)

GLOBE B FUSIBLE LINKS are U.L. Listed and FM approved for use with extinguishing systems as specified in the installation instructions. Good for 3 - 20 lbs. load. Add 2 Digit date code when ordering. Example FLG360B-19.

PART#	DESCRIPTION
FLG135B	Globe 135° B Fusible Link
FLG165B	Globe 165° B Fusible Link
FLG212B*	Globe 212° B Fusible Link
FLG280B	Globe 280° B Fusible Link
FLG360B	Globe 360° B Fusible Link



GLOBE B LINK
3 - 20 LB. Load

*Special Order

Fusible links used in cooking operations should be replaced during semi-annual maintenance, unless conditions require more frequent replacement. To verify proper maintenance has been performed, write date of insallation and the date of the fusible link on the inspection tag.

GLOBE K® FUSIBLE LINKS are U.L. Listed and U.L. Classified for use with extinguishing systems as specified in the installation instructions. Good for 3 - 50 lbs. load. Add 2 Digit date code when ordering. Example FLG360K-19.

PART#	DESCRIPTION
FLG165K	Globe 165° K Fusible Link
FLG212K	Globe 212° K Fusible Link
FLG280K	Globe 280° K Fusible Link
FLG360K	Globe 360° K Fusible Link
FLG450K	Globe 450° K Fusible Link



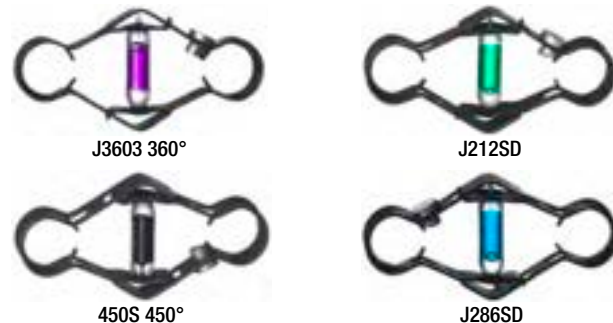
RANGE GUARD FUSIBLE LINKS. Manufactured by Globe for Range Guard. For use in Range Guard Systems Stamped with “RG”.

PART#	DESCRIPTION
9100006	Fusible Link Assembly 360° w/ 2 “S” Hook
9197276	Fusible Link 360° only



The **JOB®** standard response **THERMO BULB LINK** is the latest technology for temperature release in extinguishing systems. Links are colour coded to reduce chance of wrong release temperature link being installed. U.L. Listed for kitchen hoods, fire dampers and smoke vents. COMES PACKAGED AND PRICED 5 PER HANDY DISPENSER. Load range 0 - 55 lbs.

PART#	DESCRIPTION
J165SD	BTBS Std Res Link, 165°F (74°C), Red, Pkg/5
J212SD	BTBS Std Res Link, 212°F (100°C), Green, Pkg/5
J286SD	BTBS Std Res Link, 286°F (141°C), Blue, Pkg/5
J3603	BTBS Std Res Link, 360°F (182°C), Mauve, Pkg/5
450S	BTBS Std Res Link, 450°F (232°C), Black, Pkg/5
J500S	BTBS Std Res Link, 500°F (260°C), Black, Pkg/5



PHL LINKS™ MCCABE® RESETTABLE BI-METAL FIRE LINK is a UL 33 permanent replacement for fusible links and can provide heat detection signaling and operations. Utilizing a corrosion resistant, bi-metal configuration, the McCabe Link is always resettable and reusable after repeated testing – including routine system cycles or NFPA required periodic testing for safe functioning operating tests during inspection. Built-in delay reduces nuisance tripping is reduced (15-45 seconds vs. UL standard of 1 minute). Can be operated (repeatedly) three ways: Heat, Manually or Electrically.

PART#	DESCRIPTION
E5720H16524	McCabe 165°F, Thermal Electric Bi-Metal Link, 24V w/ 55 Watt Electric Heater
E5720H165120	McCabe 165°F, Thermal Electric Bi-Metal Link, 120V w/ 55 Watt Electric Heater
E5730H21224	McCabe 212°F, Thermal Electric Bi-Metal Link, 24V w/ 55 Watt Electric Heater
E5730H212120	McCabe 212°F, Thermal Electric Bi-Metal Link, 120V w/ 55 Watt Electric Heater
E5762H165120	McCabe 165°F, Thermal Electric, 120V w/55 Watt Electric Heater Pad On Bi-Metal Link
5720165	McCabe 165°F, Thermal Resettable Bi-Metal Link, Universal Link Base



SR ELECTRO THERMAL LINK (ETL®) is a UL listed, dual-responsive fusible link and release device designed to substantially improve life safety and minimize property damage. It creates an instantaneous fusible link response and separation in the event of fire. The etl has a protruding cylinder to house the heating element and attachment wires, and to provides a means to attach a standard EMT conduit connector adapter. Load range 2 lbs. - 40 lbs. Manufactured by Globe.

PART#	DESCRIPTION
121165	ETL 165°F Fusible Link/Release Device



LINK BRACKETS AND ADAPTER KIT

This **10" FUSIBLE LINK BRACKET** is UL classified for use in Pyro-Chem® and Range Guard® systems, per NFPA 17 and 17A.

PART#	DESCRIPTION
LBK1	10" Fusible Link Bracket, ULC Classified



8" FUSIBLE LINK BRACKET is U.L. Classified for use in KIDDE systems per NFPA 17 & 17A.

PART#	DESCRIPTION
LBK2	8" Fusible Link Bracket, ULC Classified



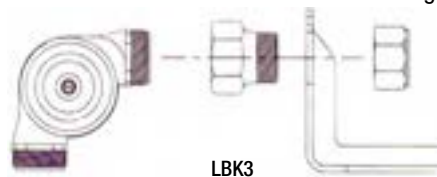
Offering better air flow around fusible links, this **10" HIGH STAND OFF FUSIBLE LINK BRACKET** is UL classified for use in Pyro-Chem® and Range Guard® systems, per NFPA 17 and 17A. And it will match up to a CP5 when coming through the top of a hood with a QSA12.

PART#	DESCRIPTION
LBK3	10" High Stand-off Fusible Link Bracket, ULC Classified, 1 1/8" to Centre of Hole



Facilitating the attachment of an Ansul® or Pyro-Chem® large-threaded corner pulley to an LBK3 fusible link bracket, this Link HOUSING ADAPTER KIT reduces the larger threads of the corner pulley to fit the smaller-diameter link bracket hole. No conduit or conduit fittings are required either. Kit comes with one reducing adaptor and one steel nut.

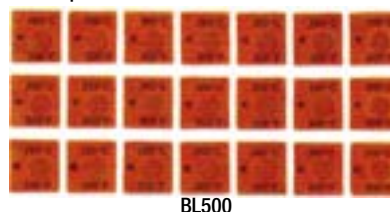
PART#	DESCRIPTION
LHAK	Link Housing Adaptor Kit



TEMPERATURE LABELS

Install **TEMPERATURE LABELS** on link brackets and take the guesswork out of fusible link installation. Dot turns black if temperature is reached, demonstrating that the link reacts to temperature as designed. Measures 1/2" square with 1/4" dot in the center. Twenty-one labels per card.

PART#	DESCRIPTION
BL500	500°F Temperature Labels



EMT FITTINGS

EMT CONDUIT FITTINGS

PART#	DESCRIPTION
1210	1/2" EMT Set Screw Connector - Each
1220	1/2" EMT Set Screw Coupling - Each
2105	1/2" EMT Compression Connector - Each
2205	1/2" EMT Compression Coupling - Each
2232	Steel 1/2" EMT Fitting for Hood Seals - Each
1505	1/2" EMT and 3/8" Pipe Hole Strap (PACKAGE OF 100)
7800	Standoff Clamp with Nut and Bolt - Each for 1/2" EMT, 1/2" & 3/8" Pipe (3 1/2" Long)



GREASE-TITE ADAPTERS AND PATCH SEALS

“SEAL-FAST” HOOD ADAPTERS

THREADED “SEAL-FAST” HOOD ADAPTERS are U.L. Listed and conform to NFPA 96 requirements and are made of chrome plated steel.

PART#	DESCRIPTION	H SIZE	P SIZE
QSA1	Pipe Adapter	7/8"	3/8"
QSA38	Pipe Adapter	1 1/8"	3/8"
QSA2	Pipe & Conduit Adapter	1 1/8"	1/2"
QSA3	Pipe Adapter	1 3/8"	3/4"
QSA4	Pipe Adapter	1 5/8"	1"
*QSA5	Pipe Adapter	7/8"	1/4"

*Special Order

THREADED SEAL-FAST HOOD ADAPTERS



QSA1 / QSA38 / QSA2 / QSA3 / QSA4 / QSA5



QSA2 w/conduit fittings

COMPRESSION “SEAL-FAST” ADAPTERS allow sealing without cutting and threading.

PART#	DESCRIPTION	H SIZE	P SIZE
QSA8	5/8" Tube & 3/8" Pipe Compression Seal	1 1/8"	3/8"
QSA9	1/2" EMT Conduit Compression Seal	1 1/8"	1/2"
QSA10	1/2" Pipe Compression Seal	1 1/8"	1/2"
QSA11	3/4" Pipe Compression Seal	1 3/8"	3/4"
QSA1129	2" Tube Compression Seal	2 1/4"	
QSA1418	1/8" Tube/Wire Compression Seal	3/4"	

NEW
NEW

NEW

COMPRESSION SEAL



QSA8 / QSA9 / QSA10 / QSA11



QSA1129



QSA1418

CORNER PULLEY “SEAL-FAST” ADAPTERS allow for screwing the corner pulley directly into the adapter for a quick 90° turn when coming thru the top of the hood. **NOTE:** Old style KIDDE and Range Guard corner pulleys will not fit.

CORNER PULLEY SEAL FAST ADAPTER

PART#	DESCRIPTION	H SIZE
QSA12	Corner Pulley Adapter	1 1/8"
*QSA13	New Style Ansul Corner Pulley Adapter	1 1/8"

*Not Shown



QSA12

QSA13

PATCH SEALS for patching those unwanted holes.

PART#	DESCRIPTION	H SIZE
QP1	“Seal-Fast” Patch	1 1/8" - 1 3/8"
QP2	“Seal-Fast” Patch	7/8" - 1 1/8"
QP3	“Seal-Fast” Patch	1 5/8"

PATCH SEAL



QP1

QP2

QP3

This **EMT FITTING** is custom made to fit all threaded hood seal adapters quickly and easily without force. Since zinc die cast fittings can melt when there's a fire, these fittings are made of zinc-plated steel. **NOTE:** The use of steel EMT Fittings inside a hood canopy guards against failure due to high heat and helps ensure proper fire suppression system operation.

PART#	DESCRIPTION
2232	Steel 1/2" EMT Fitting for Hood Seals/Link Brackets Will Screw into QSA2



2232

CUSTOM MADE TO FIT!

Quick-Patch for Corner Pulley

Modifying the kitchen fire suppression system often requires removing the corner pulley adaptors from the hood. With our new UL listed Evergreen **QUICK PATCH FOR CORNER PULLEY**, you simply install the new patch in the existing hood seal once the corner pulley is removed.

PART#	DESCRIPTION
QP1476	Quick Patch for 7/8" threaded Corner Pully Used on BECO, Buckeye & Range Guard Corner Pulleys
QP1478	Quick Patch for 15/16" threaded Corner Pully Used on Ansul, Pyrochem Corner Pulleys



Blind Seals

The patented Evergreen Blind Seals are a unique solution allows installation of seals from one side of the penetration when access to the backside is not convenient or possible. The UL Listed Evergreen **BLIND SEAL** allows installation by a single installer from one side of the hood.

PART#	DESCRIPTION
BS1287	3/4" Pipe Blind Compression Seal
BS1232	1/4" Pipe Blind Quick-Seal
BS1272	3/4" Pipe Blind Quick Seal



CORNER PULLEYS

BROOKS' high temperature, ball bearing **COMPRESSION CORNER PULLEY** is UL listed with the **Amerex** sytem and UL classified for **Ansul, Kidde, PyroChem** and **Range Guard** systems per NFPA 17 amd 17A. Steel compression nuts eliminate stripping. Our pulleys have more threads per inch than most making it easier to install with no snap rings. They are pressed into place to stay when you remove the cover too.

PART#	DESCRIPTION
CP5	Compression Corner Pulley

INSTALLS WITHOUT SMP RINGS



High temperature **SET SCREW CORNER PULLEY** comes with ball bearing roller.

PART#	DESCRIPTION
CP8	Set Screw Corner Pulley



ANSUL COMPRESSION TYPE and high temp **SET SCREW CORNER PULLEYS**.

PART#	DESCRIPTION
423250AS	Ansul Corner Pulley, Compression Type
415670AS	Set Screw Corner Pulley



ANSUL-style, low temperature Corner pulley.

PART#	DESCRIPTION
CP6	Ansul-Style Conduit Corner Pulley
CP7	Ansul-Style Threaded Corner Pulley



BROOKS' low temperature **SWING COVER CORNER PULLEYS**.

PART#	DESCRIPTION
CP2	Swing Cover Corner Pulley



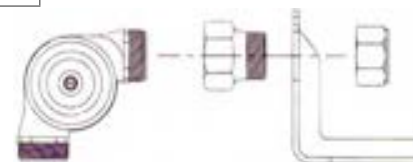
BROOKS' **3-WAY CORNER PULLEY** comes with dual rollers.

PART#	DESCRIPTION
CP3	3-Way Corner Pulley



LINK HOUSING ADAPTER KIT allows attachment of the **Ansul 423250AS** and **Brooks CP5** corner pulley to the **LBK3** hole link bracket. This kit reduces the larger threads of the corner pulley to fit the smaller diameter link bracket hole. No conduit or conduit fittings are required. Kit includes one reducing adapter and one steel nut.

PART#	DESCRIPTION
LHAK	Link Housing Adapter Kit



PIPE FITTINGS AND NIPPLES

#304 STAINLESS STEEL FITTINGS AND PIPE NIPPLES



Specifications:

- #304 Stainless Steel
- Nickel Plated for an attractive finish
- ASTM Schedule 40

90° ELBOWS

PART#	DESCRIPTION
SS02	Stainless Steel 3/8" 90° Elbow
SS03	Stainless Steel 1/2" 90° Elbow



TEES

PART#	DESCRIPTION
SS12	Stainless Steel 3/8" Tee
SS13	Stainless Steel 1/2" Tee



COUPLINGS

PART#	DESCRIPTION
SS17	Stainless Steel 3/8" Coupling
SS18	Stainless Steel 1/2" Coupling



REDUCING COUPLING

PART#	DESCRIPTION
SS28	Stainless Steel 1/2" x 3/8" Reducing Coupling



UNIONS

PART#	DESCRIPTION
SS22	Stainless Steel 3/8" Union
SS23	Stainless Steel 1/2" Union



PIPE NIPPLES are threaded on both ends.

PART#	DESCRIPTION
SS3800	Stainless Steel 3/8" Close Nipple
SS3820	Stainless Steel 3/8" x 2" Pipe Nipple
SS3830	Stainless Steel 3/8" x 3" Pipe Nipple
SS3840	Stainless Steel 3/8" x 4" Pipe Nipple
SS3850	Stainless Steel 3/8" x 5" Pipe Nipple
SS3855	Stainless Steel 3/8" x 5 1/2" Pipe Nipple
SS3860	Stainless Steel 3/8" x 6" Pipe Nipple
SS5000	Stainless Steel 1/2" Closed Nipple
SS5020	Stainless Steel 1/2" x 2" Pipe Nipple
SS5030	Stainless Steel 1/2" x 3" Pipe Nipple



STAINLESS STEEL PIPE SLEEVES are threaded on both ends.

PART#	DESCRIPTION
SS3884	Stainless Steel 3/8" x 7' (84")
SS50120	Stainless Steel 1/2" x 10'



BLACK PIPE FITTINGS AND PIPE NIPPLES

Specifications:

- ASTM Schedule 40

ELBOWS

PART#	DESCRIPTION
BP1	Black 1/4" 90° Elbow
BP2	Black 3/8" 90° Elbow
BP3	Black 1/2" 90° Elbow
BP4	Black 3/4" 90° Elbow
BP7	Black 3/8" 45° Elbow
BP8	Black 1/2" 45° Elbow



90° ELBOW



45° ELBOW

REDUCING ELBOWS

PART#	DESCRIPTION
BP36	Black 1/2" x 3/8" 90° Reducing Elbow
BP37	Black 1/2" x 3/4" 90° Reducing Elbow



90° REDUCING ELBOW

REDUCING TEE

PART#	DESCRIPTION
BP45	Black 1/2" x 1/2" x 3/8" Bull Reducing Tee



BULL REDUCING TEE

TEES

PART#	DESCRIPTION
BP11	Black 1/4" Tee
BP12	Black 3/8" Tee
BP13	Black 1/2" Tee
BP14	Black 3/4" Tee



TEE

COUPLINGS

PART#	DESCRIPTION
BP16	Black 1/4" Coupling
BP17	Black 3/8" Coupling
BP18	Black 1/2" Coupling



COUPLING

REDUCING COUPLINGS

PART#	DESCRIPTION
BP26	Black 3/8" x 1/4" Reducing Coupling
BP28	Black 1/2" x 3/8" Reducing Coupling
BP29	Black 3/4" x 1/2" Reducing Coupling



REDUCING COUPLING



PIPE NIPPLES

UNIONS

PART#	DESCRIPTION
BP21	Black 1/4" Union
BP22	Black 3/8" Union
BP23	Black 1/2" Union
BP24	Black 3/4" Union



UNION

BUSHINGS

PART#	DESCRIPTION
BP38	Black 3/8" x 1/4" Bushing
BP39	Black 3/4" x 1/2" Bushing
BP44	Black 1/2" x 3/8" Bushing
BP46	Black 3/4" x 3/8" Bushing



BUSHING

LOCKNUTS

PART#	DESCRIPTION
BP41	Black 3/8" Locknut
BP42	Black 1/2" Locknut
BP43	Black 3/4" Locknut



LOCKNUT

PLUGS

PART#	DESCRIPTION
BP50	Black 3/8" Plug
BP55	Black 1/2" Plug



PLUG

3/8" BLACK PIPE NIPPLES are threaded on both ends.

PART#	DESCRIPTION
N3800	3/8" Close Black Pipe Nipple
N3815	3/8" x 1 1/2" Black Pipe Nipple
N3820	3/8" x 2" Black Pipe Nipple
N3825	3/8" x 2 1/2" Black Pipe Nipple
N3830	3/8" x 3" Black Pipe Nipple
N3835	3/8" x 3 1/2" Black Pipe Nipple
N3840	3/8" x 4" Black Pipe Nipple
N3845	3/8" x 4 1/2" Black Pipe Nipple
N3850	3/8" x 5" Black Pipe Nipple
N3855	3/8" x 5 1/2" Black Pipe Nipple
N3860	3/8" x 6" Black Pipe Nipple
N3812	3/8" x 12" Black Pipe Nipple
N3818	3/8" x 18" Black Pipe Nipple
N3824	3/8" x 24" Black Pipe Nipple
N3836	3/8" x 36" Black Pipe Nipple
N3884	3/8" x 7" (84") Black Pipe Nipple
N38120	3/8" x 10' Black Pipe Nipple



CLOSE NIPPLE

1/2" BLACK PIPE NIPPLES are threaded on both ends.

PART#	DESCRIPTION
N5000	1/2" Close Black Pipe Nipple
N5015	1/2" x 1 1/2" Black Pipe Nipple
N5020	1/2" x 2" Black Pipe Nipple
N5030	1/2" x 3" Black Pipe Nipple
N5040	1/2" x 4" Black Pipe Nipple
N5050	1/2" x 5" Black Pipe Nipple
N5060	1/2" x 6" Black Pipe Nipple
N5012	1/2" x 12" Black Pipe Nipple
N5018	1/2" x 18" Black Pipe Nipple
N5024	1/2" x 24" Black Pipe Nipple
N5036	1/2" x 36" Black Pipe Nipple
N5084	1/2" x 7' Black Pipe Nipple



CLOSE NIPPLE



PIPE NIPPLE

REDUCING COUPLING

PART#	DESCRIPTION
CR28	Chrome 1/2" x 3/8" Reducing Coupling



REDUCING COUPLING

UNIONS

PART#	DESCRIPTION
CR22	Chrome 3/8" Union
CR23	Chrome 1/2" Union
CR24	Chrome 3/4" Union



UNION



BUSHING

BUSHING

PART#	DESCRIPTION
CR44	Chrome 1/2" x 3/8" Bushing

CHROMED PIPE FITTINGS AND PIPE NIPPLES

Specifications:

- ASTM Schedule 40

ELBOWS

PART#	DESCRIPTION
CR1	Chrome 1/4" 90° Elbow
CR2	Chrome 3/8" 90° Elbow
CR3	Chrome 1/2" 90° Elbow
CR4	Chrome 3/4" 90° Elbow
CR7	Chrome 3/8" 45° Elbow



90° ELBOW



45° ELBOW



90° REDUCING ELBOW



TEE

REDUCING ELBOW

PART#	DESCRIPTION
CR36	Chrome 1/2" x 3/8" 90° Reducing Elbow

TEES

PART#	DESCRIPTION
CR12	Chrome 3/8" Tee
CR13	Chrome 1/2" Tee

REDUCING TEE

PART#	DESCRIPTION
CR45	Chrome 1/2" x 1/2" x 3/8" Bull Reducing Tee



REDUCING TEE



COUPLING

COUPLINGS

PART#	DESCRIPTION
CR17	Chrome 3/8" Coupling
CR18	Chrome 1/2" Coupling

3/8" CHROME PIPE NIPPLES - polished

PART#	DESCRIPTION
CRN3800	3/8" Close Nipple
CRN3815	3/8" x 1 1/2" Chrome Pipe Nipple
CRN3820	3/8" x 2" Chrome Pipe Nipple
CRN3825	3/8" x 2 1/2" Chrome Pipe Nipple
CRN3830	3/8" x 3" Chrome Pipe Nipple
CRN3835	3/8" x 3 1/2" Chrome Pipe Nipple
CRN3840	3/8" x 4" Chrome Pipe Nipple
CRN3845	3/8" x 4 1/2" Chrome Pipe Nipple
CRN3850	3/8" x 5" Chrome Pipe Nipple
CRN3855	3/8" x 5 1/2" Chrome Pipe Nipple
CRN3860	3/8" x 6" Chrome Pipe Nipple
CRN3880	3/8" x 8" Chrome Pipe Nipple
CRN3810	3/8" x 10" Chrome Pipe Nipple
CRN3812	3/8" x 12" Chrome Pipe Nipple
CRN3818	3/8" x 18" Chrome Pipe Nipple
CRN3824	3/8" x 24" Chrome Pipe Nipple
CRN3836	3/8" x 36" Chrome Pipe Nipple



CRN3800



POLISHED 3/8" CHROME PIPE



CHROME NIPPLES

CHROME SLEEVING

High lustre Chrome Sleaving made of 22 gauge minimum thickness steel. The best quality in the industry! Our CS25 is actual chrome conduit size, so there is no need for sleaving.

PART#	DESCRIPTION
CS25	6' Chrome 1/2" Conduit
CS38	6' Chrome Sleaving for 3/8" Pipe
CS50	6' Chrome Sleaving for 1/2" Pipe
CS75	6' Chrome Sleaving for 3/4" Pipe
CS100	6' Chrome Sleaving for 1" Pipe



CHROME SLEAVING

PIPE STAND-OFF BRACKETS

STAND OFF BRACKETS FOR HOOD AND DUCT RESTAURANT SYSTEMS

MADE IN CANADA 🇨🇦

FOR 1/2" EMT CONDUIT, 3/8" AND 1/2" PIPE FOR MOST MANUFACTURERS

- Ansul • Amerex • Buckeye • LBK3 • Pyrochem • Range Guard • Kidde

Designed to line up with fusible link bracket hole for quick and easy installation

FOR ANSUL • AMEREX • BUCKEYE • LBK3 • PYROCHEM
1/2" E.M.T. CONDUIT

PART#	DESCRIPTION
SBC05	1/2" E.M.T. Conduit Stand Off Bracket, 2 5/8" O.H. x 1 7/8" to centre of link hole Zinc plated 16 Gauge Steel • No Sharp Corners

3/8" PIPE

PART#	DESCRIPTION
SBP10	3/8" Pipe Stand Off Bracket, 2 1/4" O.H. x 1 1/2" to centre of standoff bracket hole Zinc plated 16 Gauge Steel • No Sharp Corners

1/2" PIPE

PART#	DESCRIPTION
SBP15	1/2" Pipe Stand Off Bracket, 2 5/8" O.H. x 1 7/8" to centre of link hole Zinc plated 16 Gauge Steel • No Sharp Corners

Note: O.H. is overall height of the bracket.

FOR RANGE GUARD • KIDDE

1/2" E.M.T. CONDUIT

PART#	DESCRIPTION
SBC20RG	1/2" E.M.T. Conduit Stand Off Bracket, 3 1/4" O.H. x 2 1/2" to centre of link hole Zinc plated 16 Gauge Steel • No Sharp Corners

3/8" PIPE

PART#	DESCRIPTION
SBP38RG	3/8" Pipe Stand Off Bracket, 3 1/4" O.H. x 2 1/2" to centre of link hole Zinc plated 16 Gauge Steel • No Sharp Corners

1/2" PIPE

PART#	DESCRIPTION
SBP250RG	1/2" Pipe Stand Off Bracket, 3 1/4" O.H. x 2 1/2" to centre of link hole Zinc plated 16 Gauge Steel • No Sharp Corners



HOOD AND DUCT MOUNT FASTENERS AND TOOLS

See page 263 for more information.

PART#	DESCRIPTION	PKG/QTY
QDRILL*	Quick Mount Drill Bit 3/8"	
QMT00LM	Wrench Type Installation Tool	
QMT	Quick Mount® Fastener	Pkg. of 100
QMS	1/4" - 20 Screw for QMT	Pkg. of 100
QMT00L	Lever Type Installation Tool	
1404	Grease-Tite Seal Fasteners, Pkg/24	
TL1395	100 mm Magnetic Power Driver For Grease-Tite Fasteners	
1399DB	Double Ended 1/8" Pilot Drill Bit	

*Not Shown



QMS, QMT



CLASSIFIED



QMT00LM



1404



QMT00L



TL1395



1399DB

HOOD GREASE FILTERS AND ACCESSORIES

HOOD FILTERS

Aluminum hood **GREASE FILTERS** are lightweight for easy handling. Replaces mesh filters that are no longer acceptable per NFPA 96. Each filter includes handles.

NOTE: Actual height and width measure 7/16" less than nominal sizes. All filters measure 1/4" thick.

ALUMINUM	
PART#	DESCRIPTION
AF1016	10"H x 16"W Aluminum Hood Filter
AF1020	10"H x 20"W Aluminum Hood Filter
AF1216	12"H x 16"W Aluminum Hood Filter
AF1220	12"H x 20"W Aluminum Hood Filter
AF1616	16"H x 16"W Aluminum Hood Filter
AF1620	16"H x 20"W Aluminum Hood Filter
AF1625	16"H x 25"W Aluminum Hood Filter
AF2016	20"H x 16"W Aluminum Hood Filter
AF2020	20"H x 20"W Aluminum Hood Filter
AF2025	20"H x 25"W Aluminum Hood Filter
AF2516	25"H x 16"W Aluminum Hood Filter
AF2520	25"H x 20"W Aluminum Hood Filter



AF1016



AF1625



AF2016

CUSTOM FILTERS OF ALL SIZES ARE NOW AVAILABLE



AF2020



AF2025



SSF2020



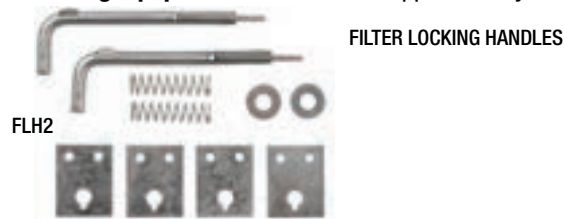
GVF2020

STAINLESS STEEL	
PART#	DESCRIPTION
SSF1620	16"H x 20"W Stainless Steel Hood Filter
SSF2020	20"H x 20"W Stainless Steel Hood Filter

GALVANIZED	
PART#	DESCRIPTION
GVF2020	20"H x 20"W Galvanized Hood Filter

POSI-SET BRACKETS are designed to **precisely locate mobile cooking equipment** below the fire suppression system, in accordance with NFPA 96 and NFPA 17A requirements. Includes hardware.

PART#	DESCRIPTION
FLH2	Filter Locking Handle (Pair)
PS2	POSI-SET Brackets



HOOD GREASE SCRAPER with 4" heavy-duty blade and a 6" handle. Designed for maximum hood cleaning efficiency.

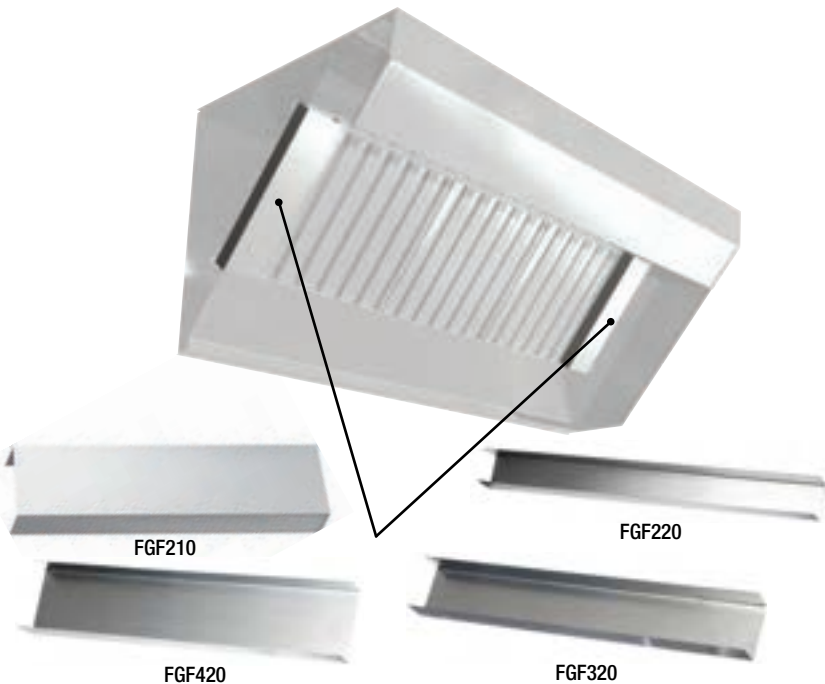
PART#	DESCRIPTION
HS690	Hood Grease Scraper
SB698	Replacement Blades for HS690, Pkg. of 10



FILTER SPACERS

HOOD FILTER SPACERS allow you to fill in those few inches of plenum space not covered by standard size filters. Use them to fill that space that is not critical to the air flow and system detection. This will force the air flow through the filters as intended. **DO NOT** place fusible links directly above a spacer as there is limited air flow in this area. Hint: seal spacers together to cover those larger spaces with our HS1 Hood Caulk. Spacers are made of 20 gauge, 430 Stainless Steel with a brushed finish.

PART#	DESCRIPTION	W X L
FGF210	Filter Spacer	2" x 10"
FGF310	Filter Spacer	3" x 10"
FGF410	Filter Spacer	4" x 10"
FGF212	Filter Spacer	2" x 12"
FGF312	Filter Spacer	3" x 12"
FGF412	Filter Spacer	4" x 12"
FGF216	Filter Spacer	2" x 16"
FGF316	Filter Spacer	3" x 16"
FGF416	Filter Spacer	4" x 16"
FGF220	Filter Spacer	2" x 20"
FGF320	Filter Spacer	3" x 20"
FGF420	Filter Spacer	4" x 20"
FGF225	Filter Spacer	2" x 25"
FGF325	Filter Spacer	3" x 25"
FGF425	Filter Spacer	4" x 25"



NOTE: Actual height and width measure 7/16" less than nominal sizes. All filters measure 1/4" thick.

HOOD LIGHT FIXTURES

Complete **HOOD LIGHT FIXTURE** made of cast aluminum. Comes prewired with 6" leads and a frosted plastic coated heat tempered globe that won't discolour when exposed to heat.

PART#	DESCRIPTION
HLF	Hood Light Fixture with Coated Globe
PCG	Replacement Globe for Hood Light (HLF)
HLWG	Wire Guard for Hood Light



DUCTMATE RECTANGULAR HI TEMP ACCESS DOORS

DUCTMATE® **DUCT ACCESS DOORS** provide easy access to grease ducts or high-temperature duct systems. They are simple to install and provide a leak-resistant seal. Just cut the hole and install. It's that easy! No measuring is required because a stick-on template is provided. And when an inspection is necessary, just unscrew the wing nuts to inspect - no special tools are required. Doors are rated up to 2300°F and meet NFPA 96 requirements.

PART#	DESCRIPTION
D106F2GA	Duct Access Door 10" x 6"
D128F2GA	Duct Access Door 12" x 8"
D1814F2GA	Duct Access Door 18" x 14"
D2418F2GA	Duct Access Door 24" x 18"



DUCT ACCESS DOOR

MORE SIZES AVAILABLE - CALL FOR PRICING

FRYER PANELS

FRYER PANELS are made from stainless steel with deburred edges and have a large radius corner for protection. Two sizes available and fits most fryers. Meets NFPA 96 requirement, section 12.1.2.5, which requires that a plate be installed when a fryer is closer than 16" to surface flames on an adjacent appliance.

PART#	DESCRIPTION
FP1230	Fryer Panel, Stainless Steel 12" H x 30" (GSHLD)
FP1830	Fryer Panel, Stainless Steel 18" H x 30"



FRYER PANEL

STAINLESS STEEL CLEANER/POLISHER

SHEILA SHINE

STAINLESS STEEL CLEANER/POLISHER made by Sheila Shine will remove grease film, finger marks, cover scratches and leaves a protective coating that preserves the surface looking like new.

PART#	DESCRIPTION
SSCP	Stainless Steel Cleaner/Polish (10.5 oz can)
SSCPQ	Stainless Steel Cleaner/Polish (1 quart)
SSCPG	Stainless Steel Cleaner/Polish (1 gallon)



SSCP



SSCPQ



SSCPG

GREASE COMB

The new 6" **FIRETECH™ GREASE COMB** is a must have for all hood system service techs, because it accurately measures the amount of grease buildup present on hoods, fans, ducts, and other surfaces. Now you can demonstrate to your customer when combustible contaminants are at dangerous levels. White plastic comb features depth gauge teeth clearly printed in microns for easy grease depth assessment.

PART#	DESCRIPTION	L X H X W
FTGC	Grease Comb	6" x 2 ⁵ / ₁₆ " x 7/ ₈ "



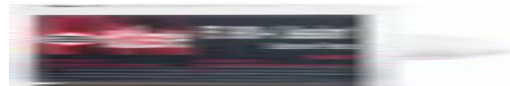
FTGC

FIRESTOP AND HOOD CAULK

FLAMESAFE FIRESTOP CAULK is for sealing penetrations in fire walls. UL Classified under "Fill or Cavity Materials". Produces a sandable, paintable surface with up to a 3-hour fire rating. Water based (no solvents or silicones).

NOT FOR HOOD USE!

PART#	DESCRIPTION
FS900	Flamesafe Caulk (10.3 oz. tube)



FS900

100% silicone **HOOD CAULK** (aluminum in colour) can be applied overhead up to 450°F. Meets FDA and USDA requirements. Does not meet NFPA requirement for sealing hood penetrations.

PART#	DESCRIPTION
HS1	Hood Caulk (10.3 oz. tube)



HS1

PROTECTIVE CLOTHING

TYVEK® **PROTECTIVE COVERALLS** with serged seams, front zipper and collar. The most popular disposable protective clothing available.

PART#	DESCRIPTION	SIZE
555L	Tyvek® Coverall	Large
555XXL	Tyvek® Coverall	XX-Large
TYBC	Boot/Shoe Cover	One Size Fits All



TYBC

FOR THOSE REAL DIRTY JOBS



TYVEK® COVERALLS

SMOKE CARTRIDGES

Regin **SMOKE CARTRIDGES** are easy to handle and nonexplosive. Great way to study make up and exhaust air, smoke stacks, etc., or to leak test duct work, pipelines, tanks, etc.

PART#	DESCRIPTION	WEIGHT	SMOKE VOL. CUBIC FEET	BURN TIME	PKG QTY
S102	Fumax	¼ oz.	150	45 seconds	10
S103	Fumax	⅓ oz.	600	1½ minute	10
S105	Brandax	2 oz.	2,500	3-4 minutes	5
S107	Brandax KS	1 lb.	18,000	5-6 minutes	1



SMOKE CARTRIDGES

TEST BALLOONS

SYSTEM TEST BALLOONS are tested by our customers and proven effective. Use to show the AHJ that the lines are open! Balloons come 25 to a pack. **DO NOT USE FOR CHEMICAL DISCHARGE!**

PART#	DESCRIPTION
STB25	System Test Balloons, Package of 25



STB25

CODES AND REGULATIONS

For nearly a century, people have relied on **N.F.P.A.® PUBLICATIONS**...your blueprints to safety!

PART#	DESCRIPTION
NFPA1018	NFPA 10: Standard for Portable Fire Extinguishers, 2018 ed.
NFPA9617	NFPA 96: Standard for Ventilation Control and Fire Protection of Commercial Cooking Operations 2017 ed.
NFPA17A17	NFPA 17A: Standard for Wet Chemical Extinguisher Systems, 2017 ed.



FOR ADDITIONAL COPIES SEE PAGE 71

SYSTEM SIGNS

Rigid Plastic

Rigid, tough plastic (1/32" thick) mounts easily to the wall with predrilled mounting holes. Screen printed with UV inks.

PART#	DESCRIPTION	W	H
RP189	K-Class "Fire Extinguisher" Arrow, Bilingual	8"	12"



RP189

Aluminum, Adhesive Backed

PART#	DESCRIPTION	W	H
A106	"Caution..." for System Hood	5"	2"
A272	Remote Pull Station	5"	3"
A273	Fire System	5"	3"
A276	Fryer	4"	2"
A277	Griddle	4"	2"
A278	Broiler	4"	2"
A281	Hood #1	4"	2"
A282	Hood #2	4"	2"
A283	Hood #3	4"	2"
A284	Hood #4	4"	2"



ANSUL R-102 AND PIRANHA WET CHEMICAL SYSTEMS

CARTRIDGES AND CAPS

PART#	DESCRIPTION
423439AS	Cartridge, Carbon Dioxide, 101-10 (TC)
423441AS	Cartridge, Carbon Dioxide, 101-20 (DOT/TC)
423443AS	Cartridge, Carbon Dioxide, 101-30 (DOT/TC)
423429AS	Cartridge, Nitrogen, LT-20-R (RHT) (DOT/TC)
423435AS	Cartridge, Nitrogen, LT-30-R (RHT) (DOT/TC)
423493AS	Cartridge, Nitrogen, R-102 Double Tank (DOT/TC)
423491AS	Cartridge, Nitrogen, LT-A-101-30 (DOT/TC)
AN77251	Cap, Cart. Shipping, RH Thread (Red Line HP, PS-30, LT, R-101 Cart.)
RHSC	RH Thread Cartridge Shipping Cap
LHSC	LH Thread Cartridge Shipping Cap



OEM LIQUID CHEMICAL

R-102 Kitchen System

PART#	DESCRIPTION
79372AS	Ansulex 3 Gal Wet Chemical For R-102 & K-Guard K01-2, K01-3
79656AS	Flushing Concentrate, 32 oz.



79372AS

Piranha Kitchen System

PART#	DESCRIPTION
423320AS	5 Gal PRX Wet Chemical For PIRANHA & K-Guard K01, K01-1
430182AS	6L PRX Wet Chemical For PIRANHA & K-Guard K01, K01-1
79656AS	Flushing Concentrate, 32 oz.



423320AS



430182AS

MICROSWITCHES

PART#	DESCRIPTION
423878AS	SPDT Microswitch, ANSUL
423879AS	DPDT Microswitch, ANSUL
423880AS	3PDT Microswitch, ANSUL
423881AS	4PDT Microswitch, ANSUL
428311AS	Alarm Initiating Microswitch, SPDT, ANSUL
MIC1	SPDT Microswitch, Generic, UL Classified
MIC2	DPDT Microswitch, Generic, UL Classified



423878AS



423879AS



MIC1



428311AS



423880AS



MIC2

NOZZLES

New **Streamlined** with **metal blow-off caps** are designed to mitigate potential grease buildup. Laser etching on three sides for improved nozzle identification. Metal blow-off caps included. Note: Will not use previous metal or rubber blow-off caps.

R-102 Kitchen System

PART#	DESCRIPTION
443319AS	1F Nozzle, R-102
443321AS	½ N Nozzle, R-102
443317AS	1N Nozzle, R-102
443323AS	1W Nozzle, R-102
443325AS	2W Nozzle, R-102
443327AS	3N Nozzle, R-102
443329AS	230 Nozzle, R-102
443331AS	245 Nozzle, R-102
443333AS	260 Nozzle, R-102
443335AS	290 Nozzle, R-102
443337AS	2120 Nozzle, R-102



443321AS



443323AS



443329AS



443333AS



443317AS



443327AS



443331AS



443335AS

Piranha Kitchen System

PART#	DESCRIPTION
443339AS	AP, Appliance/Plenum Nozzle, Piranha (44006)
443341AS	DL, Duct/Low Proximity Nozzle, Piranha (44009, 44334)

NOZZLE BLOW-OFF CAPS, ADAPTORS AND AIMING DEVICES

Streamlined nozzles with metal blow-off caps are direct replacements for the older rubber blow-off cap nozzles.

NOTE: Rubber blow-off caps are to be replaced annually. Do not use on the new streamlined nozzles. When rubber blow-off caps are no longer available, you must use the Streamlined Nozzles.

PART#	DESCRIPTION
418569AS	Nozzle Swivel Adaptor
439876AS	New Aiming Device Adaptor
439877AS	Nozzle Aiming Device with New Adaptor
PC551265	Nozzle Aiming Device (No Adaptor)
77695AS	Rubber Blow-Off Caps, Pkg/50 (For Older Nozzles) (Replace Annually)
439848AS	R-102 Nozzle O'Ring, Pkg/25 (For New Streamlined Nozzle)
439861AS	Metal Blow-Off Caps for Streamlined Nozzle, Pkg/10
433208AS	CB Metal Blow-Off Cap, Pkg/10



Dow Corning® **SILICONE GREASE NO. 111** is recommended by Ansul for use with rubber and metal blow-off caps on discharge nozzles, protecting both caps and nozzle orifices. Re-application required at each semi-annual maintenance examination.

PART#	DESCRIPTION
A78112	Nozzle Lubricant, Dow Corning Silicone Grease No. 111



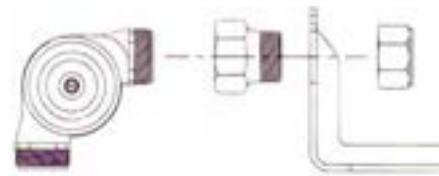
DETECTORS AND PARTS

PART#	DESCRIPTION
435547AS	Series "Scissor"-Style Detector Kit
435546AS	Terminal "Scissor"-Style Detector Kit
435545AS	Replacement Linkage Scissors, Stainless Steel



Facilitating the attachment of an Ansul® or Pyro-Chem® large-threaded corner pulley to an LBK3 fusible link bracket, this Link HOUSING ADAPTER KIT reduces the larger threads of the corner pulley to fit the smaller-diameter link bracket hole. No conduit or conduit fittings are required either. Kit comes with one reducing adapter and one steel nut.

PART#	DESCRIPTION
LHAK	Link Housing Adapter Kit



CORNER PULLEYS

PART#	DESCRIPTION
423250AS	Ansul Corner Pulley, Compression Type
415670AS	Ansul Set Screw Corner Pulley
CP5	ULC Classified Compression Corner Pulley, ½" EMT
CP3	3-Way Corner Pulley



GAS VALVES AND ACCESSORIES

ANSUL Mechanical Gas Valves are ULC listed for use in ANSUL SYSTEMS per NFPA 17 & 17A. The largest available is 3". Complete with Piston Kit Assembly. Ansul Valves include the actuator cylinder, order 15733AS separately for the ASCO valves.

PART#	DESCRIPTION
GVB55598	Gas Valve, Mechanical, 3/4" ANSUL
GVB55601	Gas Valve, Mechanical, 1" ANSUL
GVB55604	Gas Valve, Mechanical, 1 1/4" ANSUL
GVB55607	Gas Valve, Mechanical, 1 1/2" ANSUL
GVB55610	Gas Valve, Mechanical, 2" ANSUL
GVB25937	Gas Valve, Mechanical, 2 1/2" ANSUL
GVB25938	Gas Valve, Mechanical, 3" ANSUL
15733AS	Pneumatic Piston Kit (Ansul)
416018AS	Cocking Lever, Mechanical Gas Valve



GVB55607

ANSUL GENERIC Pneumatic piston for actuation of a mechanical gas valve. This item U.L. Classified to be used in ANSUL systems per NFPA 17 & 17A and the manufacturers installation instructions.

PART#	DESCRIPTION
PKA	Ansul GENERIC Style Pneumatic Piston Kit
PKAKIT	Replacement PKA Hardware Only



PKA

REMOTE PULL STATIONS AND ACCESSORIES

PART#	DESCRIPTION
434618AS	Mechanical Pull Station w/o Cable
435960AS	Mechanical Pull Station with 50 ft Cable
435726AS	Replacement "Pull" Tabs, Pkg/10
ASRP	Ansul Generic Remote Pull
RPTI	Stainless Steel Trim
RPBOX	Non-Chrome Remote Pull Junction Box
ARBOX	Chrome Remote Pull Junction Box
ASBR	Ansul Style Remote Break Rods, 10/Pkg



ASRP



ARBOX



ASBR

FLEXIBLE CONDUIT AND ACCESSORIES

PART#	DESCRIPTION
434525AS	Flexible Conduit, 500'
435959AS	Flexible Conduit w/ Wire Rope, 500'
435979AS	Flexible Conduit Strain Relief, Pkg/50
434347AS	Flexible Conduit Inserts, Pkg/50
436150AS	P-Clips, Pkg/50
436063AS	Conduit Offsets, Pkg/6

ANSUL SYSTEM ACCESSORIES

PART#	DESCRIPTION
79318AS	Regulator, 100 PSI, Mini-Bulk, Actuation Pressure
417911AS	Bursting Disc, (R-102) Pkg/10
416970AS	Bursting Disc Union Assembly
AS56909	Collar O-Ring, System Tank
68800AS	Vent Plug
418511AS	Hose/Grommet Package



417911AS



416970AS

R-102 BURSTING DISCS are installed to prevent extinguishing agents from entering the pipe during extreme temperature variations. Pkg/10.

NOTE: R102BDA (compares to Ansul) is for R-102 wet chemical systems only. Disc Burst Pressure 20-45 PSI.

PART#	DESCRIPTION
R102BDA	R-102 Bursting Disc, Generic Ansul-Type, Pkg/10

U.L. Classified ANSUL Generic aluminum bursting disc with soft vinyl washer. **For Dry Systems Only.** Disc Burst Pressure 75-105 PSI.

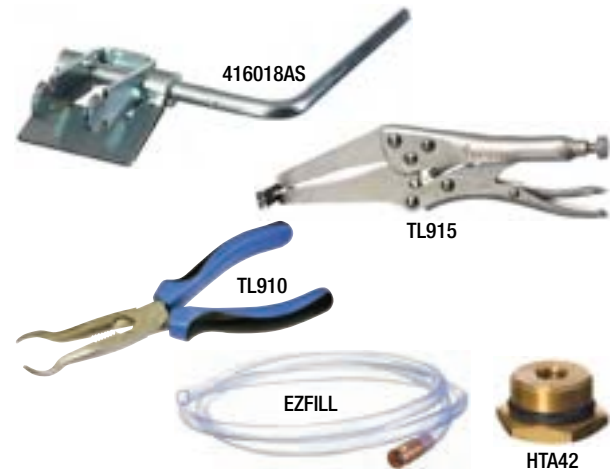
PART#	DESCRIPTION
BDA	Generic Ansul Aluminum Burst Disc for Dry Chemical Systems Only



BDA

SERVICE TOOLS

PART#	DESCRIPTION
441041AS	Ansul Cocking Lever with Lock Bar
441042AS	Ansul Short Cocking Lever and Bar
14985AS	Ansul Lock Bar (only)
438031AS	Ansul Locking Pin
416018AS	Cocking Lever, Mechanical Gas Valve
TL915	System Linkage Pliers (Locking)
TL910	System Linkage Pliers (Non-Locking)
EZFILL	Liquid EZ-Fill Siphon Tube
HTA42	Hydro Adaptor, R-102 w/Internal Threads, UL300 Stainless Steel Cylinder



Regulator Test kit for testing the ANSUL Automan regulator as required every 12 years per the ANSUL maintenance manual.

PART#	DESCRIPTION
RTK	R-102 Regulator Test Kit



RTK

SERVICE MANUALS

PART#	DESCRIPTION
418087AS	R-102 UL300 Wet System Manual, Electronic Copy

KIDDE AND BADGER RANGE GUARD WET CHEMICAL AND INDUSTRY GUARD DRY CHEMICAL SYSTEMS

CYLINDER INSTALLATION

PART#	DESCRIPTION
844908KR	Discharge Adapter Kit (one required for each cylinder)
120042KR	System Valve Actuator (SVA) (one required for each cylinder)
131024KR	Gauge Shield
96984KR	Vent Plug (WET CHEM ONLY, one required in each piping system)



844908KR



96984KR

Kidde and Badger Range Guard Wet Chemical

PART#	DESCRIPTION
9197430KR	Wall Bracket, 1.3 Gallon Cylinder
9197263KR	Wall Bracket, 2.6 Gallon Cylinder
9197415KR	Wall Bracket, 4 Gallon Short Cylinder
9197414	Wall Bracket, 4 Gallon Medium Cylinder
100013KR	Shelf Bracket, 6 Gallon & 4 Gallon Medium Cylinder (Requires 87-10010-001 for Floor Mount)
100010KR	Floor Mounting Kit for 6 Gallon & 4 Gallon Medium Cylinders (REQUIRES 87-100013-001 Shelf Bracket)
WK255700	Replacement Bracket Strap, 1.3 & 2.6 Gallon Wet Chemical Cylinders, 21/25/45/50 lb Dry Chemical Cylinders
117989KR	Replacement Bracket Strap, 4 & 6 Gallon Wet Chemical Cylinders, 70/75 lb Dry Chemical Cylinders

Industry Guard Dry Chemical

PART#	DESCRIPTION
B486487	Wall Bracket, 21lb ABC & 25lb BC Cylinder
B486488	Wall Bracket, 45lb ABC & 50lb BC Cylinder
B100009	Wall/Floor Bracket, 70lb ABC & 75lb BC Cylinder (Requires 87-100010-001 for Floor Mount)
100010KR	Floor Mounting Kit for 70lb ABC & 75lb BC Cylinder (Requires 87-100009-001 Shelf Bracket)
WK255700	Replacement Bracket Strap, 1.3 & 2.6 Gallon Wet Chemical Cylinders, 21/25/45/50 lb Dry Chemical Cylinders
117989KR	Replacement Bracket Strap, 4 & 6 Gallon Wet Chemical Cylinders, 70/75 lb Dry Chemical Cylinders

NOZZLES AND ACCESSORIES

Kidde and Badger Range Guard Wet Chemical

PART#	DESCRIPTION
120016KR	ADP nozzle
120017KR	F nozzle
120018KR	GRW nozzle
120019KR	R nozzle
120020KR	DM nozzle
120023KR	LPF nozzle
120025KR	LPR nozzle
120021KR	Swivel Adapter, 3/8"
97054KR	Replacement Nozzle Seals (pack of 10)
9196976KR	Replacement Nozzle Disc Cap - NOT for LPR Nozzle
120026KR	Replacement LPR Nozzle Disc Cap - LPR Nozzle ONLY



120016KR

120017KR

120018KR

120019KR

120023KR

120020KR

97054KR

120021KR

120025KR

9196976KR

We are in the business of growing your business

NOZZLES AND ACCESSORIES CONTINUED

Industry Guard Dry Chemical

PART#	DESCRIPTION
B100005	Total Flooding (TF) Nozzle
B100006	Duct/Plenum (DP) Nozzle
B100037	Three-Way Nozzle (Pit / Tunnel or Plenum / Stack Interface)
B844258	Low Overhead Nozzle
B259270	High Overhead Nozzle
B259072	Tankside Nozzle
B100050	Flow Restrictor, 3/4" NPT, for 2-nozzle in-line vehicle booth systems
B100051	Flow Restrictor, 1" NPT, for 4-nozzle in-line vehicle booth systems
B06-250099-067	Replacement Cap for Total Flooding & Three-Way Nozzles
B264742	Replacement Cap for Duct/Plenum Nozzle
B06-235348-001	Replacement Cap for Tankside Nozzle

CONTROL EQUIPMENT

UCH UNIVERSAL CONTROL HEAD FOR WET & DRY CHEMICAL SYSTEMS

PART#	DESCRIPTION
120099RG	Range Guard UCH Control System, includes: (1) 120042KR SVA, (1) 120043KR System Cartridge, (1) 120044KR Test Cartridge, (1) 120058KR EMT Connector Kit, (1) 120039KR SPDT Microswitch Kit, (1) 120039501KR SPDT Microswitch Kit
120045KR	High Pressure Hose, 7.5" Length (Required for cylinder mounted control head)
120045002KR	High Pressure Hose, 24" Length
120045003KR	High Pressure Hose, 60" Length
100034KR	Solenoid Kit (Electric Actuator), 24 VDC, UCH, XV Control
120039KR	Microswitch Kit, SPDT, solid color pigtails, UCH, XV Control
120039501KR	Microswitch Kit, SPDT, striped color pigtails, UCH, XV Control
120047KR	Microswitch Kit, SPDT, Terminal Type, Alarm / Release, XV, UCH Control
120058KR	EMT Connector Kit (EMT Connector & O-Ring, 3 sets) (must be used with Dry Chemical System)
B100035	Actuation Delay for Dry Chem Systems Only (required for Vehicle Paint Booth Systems) Includes (1) 120045KR 7.5" High Pressure Hose
B100038	Rebuild Kit for Actuation Delay
97108KR	Keeper Pin (UCH and A+)
120071KR	Flat Gasket for UCH Valve Body, Pkg/25
1419239KR	O-Ring for UCH or A+ Piercing Pin
120070KR	Piercing Pin w/O-Ring for UCH Valve Body, Pkg/10
120046KR	UCH, XV Valve Body Rebuild Kit, Includes: (1) Flat Gasket, (1) UCH Piercing Pin with O-Ring, (1) Retaining Ring, (1) Pin/Gasket Service Label
87120072KR	UCH Valve Body Update Kit, Includes: (1) Cam, (1) Flat Gasket, (1) UCH Piercing Pin with O-Ring, (1) Retaining Ring, (1) Upgrade Label
60120048RG	UCH Replacement Cover & Handle Assembly



120099RG

CONTROL EQUIPMENT CONTINUED

A+ CONTROL BOX FOR WET CHEMICAL SYSTEMS ONLY

PART#	DESCRIPTION
60-120010-001	Range Guard A+ Control Box Assembly, includes: (1) 120042KR SVA, (2) 06-235557-001 CO2 Cartridges, (2) Set screws, (1) Grommet, (1) Cover Label, (1) 60-9197142-000 Exhaust Fan Caution Label
97227KR	Microswitch, SPDT, A+, KRS-50
97228KR	Microswitch, DPDT, A+, KRS-50
97108KR	Keeper Pin (UCH and A+)
197214KR	Flat Gasket for A+ Valve Body, Pkg 25
1419239KR	O-Ring for UCH or A+ Piercing Pin
197215KR	Piercing Pin w/O-Ring for A+ Valve Body, Pkg/10
9197210KR	Valve Body Sub-assembly (A+), Includes (assembled): (1) Lever, (1) Valve Body, (1) Flat Gasket, (1) Piercing Pin, (1) O-Ring
9197202KR	Spring (A+)
97220KR	Cable Tension Block Assembly (A+)



97220KR

ACTUATION CARTRIDGES

System and Test cartridges for Kidde and Range Guard®. Actuator cartridges and o-rings must be periodically replaced in accordance with the Kidde or Range Guard® manual. Refer to manual for replacement intervals and installation instructions. TIP: Make sure to weigh cartridge before installation.

PART#	DESCRIPTION
120043KR	Nitrogen System Cartridge (UCH, XV), 236.8 grams
120044KR	Nitrogen Test Cartridge (UCH, XV) (not for use with Actuation Delay, Full Discharge or Puff tests)
PCC02	12 gm CO2 System/Test Cartridge (A+, KRS-50), Pkg/3



120043KR 120044KR PCC02

PRESSURE SWITCHES

PART#	DESCRIPTION
9197023KR	Pressure Switch, SPDT (Fire Department Tie-In)
486536KR	Pressure Switch, 3PDT

MECHANICAL ACTUATION COMPONENTS

PART#	DESCRIPTION
120064KR	Universal Link Detector Housing Kit (UCH or A+), includes: (1) Bracket, (2) Cable Crimp Sleeves, (2) S Hooks
804548KR	Low Profile Link Detector Housing Kit (UCH only), includes: (1) Bracket, (2) ½" EMT Connectors, (4) Cable Crimp Sleeves, (1) S-Hook
120110KR	Remote Manual Release, Combination Pull-to-Trip/Release-to-Trip (UCH or A+)
CP5	ULC Classified Compression Corner Pulley, ½" EMT
844648KR	Corner Pulley, ½" EMT
83-843792-000	Double Tee Pulley, for cabling 2 RMRs or 2 Mech Gas Valves (UCH only)
CP3	3-Way Pulley
9197602	In-Line Tee Pulley, for In-Line Remote
60-120100-001	Corner Pulley / Quik-Seal Adapter combination
WK-843837-000	Adapter, ½" EMT (F) x ¾" Pipe (M)
89412RG	Pneumatic Release (WET CHEMICAL ONLY)
874290	Pressure Operated Release (DRY CHEMICAL ONLY)



120110KR



CP5

844648KR



CP3

CONTROL EQUIPMENT CONTINUED

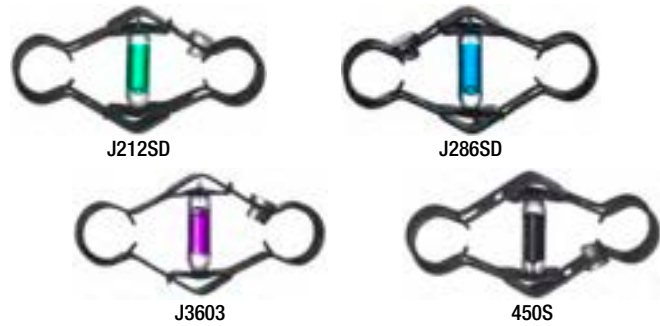
PART#	DESCRIPTION
LBK1	10" Fusible Link Bracket
LBK3	10" High Stand Off Bracket



MECHANICAL DETECTION LINKS

BTBS SERIES THERMO BULB LINKS, STANDARD RESPONSE

PART#	DESCRIPTION
J165SD	BTBS Std Res Link, 165°F (74°C), Red, Pkg/5
J212SD	BTBS Std Res Link, 212°F (100°C), Green, Pkg/5
J286SD	BTBS Std Res Link, 286°F (141°C), Blue, Pkg/5
J3603	BTBS Std Res Link, 360°F (182°C), Mauve, Pkg/5
450S	BTBS Std Res Link, 450°F (232°C), Black, Pkg/5
J500S	BTBS Std Res Link, 500°F (260°C), Black, Pkg/5



BTBR SERIES THERMO BULB LINKS, RAPID RESPONSE

PART#	DESCRIPTION
J165QR	BTBR Rapid Res Link, 165°F (74°C), Red, Pkg/5
J212QR	BTBR Rapid Res Link, 212°F (100°C), Green, Pkg/5
J286QR	BTBR Rapid Res Link, 286°F (141°C), Blue, Pkg/5
J3603QR	BTBR Rapid Res Link, 360°F (182°C), Mauve, Pkg/5
J450QR	BTBR Rapid Res Link, 450°F (232°C), Black, Pkg/5
J500QR	BTBR Rapid Res Link, 500°F (260°C), Black, Pkg/5

MODEL A FUSIBLE LINK

PART#	DESCRIPTION
9197276	RGA-360 A Link, 360°F (182°C)
FLG360A	Globe Model A Link, 360°F (182°C)



MODEL ML FUSIBLE LINK

PART#	DESCRIPTION
FLG165ML	Globe Model ML Link, 165°F (74°C)
FLG212ML	Globe Model ML Link, 212°F (100°C)
FLG360ML	Globe Model ML Link, 360°F (182°C)
FLG500ML	Globe Model ML Link, 500°F (260°C)



MODEL ML FUSIBLE LINK

DRY CHEMICAL RESERVE SYSTEM HARDWARE

PART#	DESCRIPTION
896516	Two-Way Transfer Tee, 1" NPT
802398	Main/Reserve Electric Transfer Switch
310330	Nameplate, "Main"
310340	Nameplate, "Reserve"

SYSTEM MAINTENANCE & RECHARGE

Kidde and Badger Range Guard Wet Chemical

PART#	DESCRIPTION
120067KR	Rebuild Kit - Wet & Dry Chemical Cylinder Valves, includes: (1) Valve Stem (877343) with O-Ring (6435006), (1) Valve Spring (217768KR), (1) Valve Spring Retainer (253299KR), (1) Retaining Ring Check (18490004), (1) O-Ring, Valve to Cylinder (56610327) (Only the valve spring and spring retainer are available separately)
255096KR	Valve Protection Plate (for Valve Actuation Port)
255681KR	Anti-Recoil Plate (for Valve Outlet)
WK108019	O-Ring for Discharge Adapter Kit
120009RG	Complete Valve Assembly for Range Guard Cylinders
GPC175	175 PSI Wet Chemical Gauge
118031G	175 PSI Replacement Pressure Gauge for Range Cylinder Valve
120068KR	Solid Plug, Replaces Fusible Plug on all Wet Chemical Valves ONLY
235542KR	Siphon Tube for 1.3 Gallon Cylinder
235543KR	Siphon Tube for 2.6 Gallon Cylinder
235544KR	Siphon Tube for 4 Gallon Short Cylinder
236273KR	Siphon Tube for 4 Gallon Medium Cylinder
235546KR	Siphon Tube for 6 Gallon Cylinder



Industry Guard Dry Chemical

PART#	DESCRIPTION
120067KR	Rebuild Kit - Wet & Dry Chemical Cylinder Valves, includes: (1) Valve Stem (877343) with O-Ring (6435006), (1) Valve Spring (217768KR), (1) Valve Spring Retainer (253299KR), (1) Retaining Ring Check (18490004), (1) O-Ring, Valve to Cylinder (56610327) (Only the valve spring and spring retainer are available separately)
255096KR	Valve Protection Plate (for Valve Actuation Port)
255681KR	Anti-Recoil Plate (for Valve Outlet)
WK108019	O-Ring for Discharge Adapter Kit
B878767	Complete Valve Assembly for Industry Guard Cylinders
B283951	Replacement Pressure Gauge for Industry Guard Cylinder Valve
237437KR	Brass Fusible Plug, 212°F (100°C), for IG Dry Chem Valves ONLY
WK265018	Siphon Tube for 21lb ABC & 25lb BC Cylinders
WK265019	Siphon Tube for 45lb ABC & 50lb BC Cylinders
235504IG	Siphon Tube for 70lb ABC & 75lb BC Cylinders



OEM LIQUID CHEMICAL

PART#	DESCRIPTION
120032KR	4 Gal APC Wet Chemical For Badger Range Guard and Kidde WHDR Systems
120033KR	6 Gal APC Wet Chemical For Badger Range Guard and Kidde WHDR Systems



SERVICE TOOLS

PART#	DESCRIPTION
844908KR	Discharge Adapter Kit (one required for each cylinder)
255096KR	Valve Protection Plate (for Valve Actuation Port)
255681KR	Anti-Recoil Plate (for Valve Outlet)
279262KR	Recharge Adapter
HTA24	Hydrostatic Test Adapter, Range Guard, Kidde WHDR Wet Chemical Systems
HTAFF2	Hydrostatic Test Adapter, Old Range Guard Systems
97108KR	Keeper Pin (UCH and A+)
9197090KR	3/8" Outlet Flushing Adapter



SERVICE MANUALS

PART#	DESCRIPTION
127100RG	Range Guard System Manual, UL300

SERIES 3300 MANUAL STATIONS

SPECIAL ORDER

PART#	DESCRIPTION	LEAD TIME
K84-330001-001	Kidde 3300 Conventional Dual Action Pull Station w/ toggle activated SPST Switch. Includes Label options (Kidde-Fire Alarm / Fire System Release / HALON 1301 Release / FM-200 Release / FE-13 Release / CO2 Release / Novec 1230 Release), Mounting Hardware	10 Days
K84-330001-002	Kidde 3300 Conventional Dual Action Pull Station w/ toggle activated DPST Switch. Includes Label options (Kidde-Fire Alarm / Fire System Release / HALON 1301 Release / FM-200 Release / FE-13 Release / CO2 Release / Novec 1230 Release), Mounting Hardware	10 Days
K84-100008-002	Kidde 3300 Break Rod, Package of 12	10 Days
K84-100009-001	Kidde 3300 SGB-32S Indoor Surface Back Box, Red	10 Days
K84-100009-002	Kidde 3300 SGB-32C Outdoor Weatherproof Surface Back Box, Red	10 Days
K06-231866-930	Spare Label Set for Pull Station Series 3300	10 Days
K06-118013-001	Spare Key	10 Days

DETECT-A-FIRE® (DAF) HEAT DETECTORS

Vertical DAF Units, Brass Head, Normally Open Contacts

SPECIAL ORDER

PART#	DESCRIPTION	LEAD TIME
12-E27121-000-02-0T	Model 27121-0, Vertical Mount, Brass Hex Head, 140° F (91172)	5 Days
12-E27121-000-03-0T	Model 27121-0, Vertical Mount, Brass Hex Head, 160° F (91179)	5 Days
12-E27121-000-04-0T	Model 27121-0, Vertical Mount, Brass Hex Head, 190° F (91173)	5 Days
12-E27121-000-06-0T	Model 27121-0, Vertical Mount, Brass Hex Head, 210° F	5 Days
12-E27121-000-05-0T	Model 27121-0, Vertical Mount, Brass Hex Head, 225° F (91174)	5 Days
12-F27121-000-10-0T	Model 27121-0, Vertical Mount, Brass Hex Head, 275° F (91177)	5 Days
12-F27121-000-06-0T	Model 27121-0, Vertical Mount, Brass Hex Head, 325° F (91171)	5 Days
12-F27121-000-07-0T	Model 27121-0, Vertical Mount, Brass Hex Head, 360° F	5 Days
12-G27121-000-07-0T	Model 27121-0, Vertical Mount, Brass Hex Head, 450° F (91175)	5 Days
12-G27121-000-08-0T	Model 27121-0, Vertical Mount, Brass Hex Head, 500° F	5 Days
12-H27121-000-08-0T	Model 27121-0, Vertical Mount, Brass Hex Head, 600° F (91176)	5 Days
12-H27121-000-09-0T	Model 27121-0, Vertical Mount, Brass Hex Head, 725° F	5 Days

Steel Fire 800.387.9555

DETECT-A-FIRE® (DAF) HEAT DETECTORS CONTINUED

Vertical DAF Units, Brass Hex Head, Normally Closed Contacts

SPECIAL ORDER

PART#	DESCRIPTION	LEAD TIME
12-E27120-000-02-0T	Model 27120-0, Vertical Mount, Brass Hex Head, 140° F (NORMALLY CLOSED) (91178)	5 Days
12-E27120-000-03-0T	Model 27120-0, Vertical Mount, Brass Hex Head, 160° F (NORMALLY CLOSED, CCT.)	5 Days
12-E27120-000-04-0T	Model 27120-0, Vertical Mount, Brass Hex Head, 190° F (NORMALLY CLOSED, CCT.)	5 Days
12-E27120-000-0T-210F	Model 27120-0, Vertical Mount, Brass Hex Head, 210° F (NORMALLY CLOSED, CCT.)	10 Days
12-E27120-000-05-0T	Model 27120-0, Vertical Mount, Brass Hex Head, 225° F (NORMALLY CLOSED, CCT.)	5 Days
12-F27120-000-0T-275F	Model 27120-0, Vertical Mount, Brass Hex Head, 275° F (NORMALLY CLOSED, CCT.)	10 Days
12-F27120-000-06-0T	Model 27120-0, Vertical Mount, Brass Hex Head, 325° F (NORMALLY CLOSED, CCT.)	5 Days
12-F27120-000-0T-360F	Model 27120-0, Vertical Mount, Brass Hex Head, 360° F (NORMALLY CLOSED, CCT.)	10 Days
12-G27120-000-0T-450F	Model 27120-0, Vertical Mount, Brass Hex Head, 450° F (NORMALLY CLOSED, CCT.)	10 Days

OLDER RANGE GUARD PARTS

UL classified Range Guard®-style **MICROSWITCHES** (for older control heads) come complete with wiring harnesses and hardware.

PART#	DESCRIPTION
MIC4	Range-Guard Style SPDT Microswitch
MIC5	Range-Guard Style DPDT Microswitch
MIC6	Range Guard® & Kidde-Style SPDT "A+", KRS-50, Series Microswitch
MIC7	Range Guard® & Kidde-Style DPDT "A+", KRS-50, Series Microswitch

PART#	DESCRIPTION
VSRG	Range Guard® Valve Stem (For Old RG Cylinder)
OR45	O-Ring, Ring Nut (00061)



BRASS FLARE FITTINGS

BRASS FLARE FITTINGS are for system installations and meet SAE J513, as specified in the manufacturer's manual.

NOTE: Tees and connectors do not include flare nuts.

PART#	DESCRIPTION
FC25	¼", 45° Flare x ¼" NPT Male Connector
FN25	¼", 45° Flare Nut
FT25	¼", 45° Flare Tee



PYRO-CHEM KITCHEN KNIGHT SYSTEM PARTS

ACTUATION CARTRIDGES

CO2 ACTUATOR CARTRIDGES are UL classified for Pyro-Chem and, along with O-rings, must be periodically replaced in accordance with the Pyro-Chem® manual. Refer to manual for replacement intervals and installation instructions. TIP: Make sure to check cartridge weight before installation.

PART#	DESCRIPTION
LGPC	16 gram Actuator Cartridge, Pkg/3
PC55531	O-Ring, Actuator Cartridge



LGPC

OEM LIQUID CHEMICAL

PART#	DESCRIPTION
PC300	Pyrochem 3 Gal Wet Chemical
PC553176	Pyrochem 6 L (1.6 Gal) Wet Chemical
79656AS	Flushing Concentrate, 32 oz.



PC300



PC553176

MICROSWITCHES

PART#	DESCRIPTION
PC550227	SPDT Microswitch, Old Style
PC550237	DPDT Microswitch, Old Style
PC551154	SPDT Microswitch
PC551155	DPDT Microswitch
PC551156	3PDT Microswitch
PC551157	4PDT Microswitch
PC550077	Alarm Initiating Microswitch, SPDT

You can stack (2) MIC1's to make a DPDT. For more than two switches, use OEM models. MIC1 is for Pyro-Chem MCH3 head.

PART#	DESCRIPTION
MIC1	SPDT Microswitch, Generic, UL Classified



MIC1

NOZZLES

PART#	DESCRIPTION
418569AS	Swivel Adaptor (423572)
PC551026	1L Nozzle w/ Cap
PC551027	2L Nozzle w/ Cap
PC551028	2H Nozzle w/ Cap
PC551029	1H Nozzle w/ Cap
PC551038	2D Nozzle w/ Cap



PC551026



PC551027



PC551028



PC551029



PC551038

NOZZLE BLOW-OFF CAPS, ADAPTORS AND AIMING DEVICES

PART#	DESCRIPTION
PC623	NL Series Nozzle Cap
PC550016	Rubber Nozzle Cap, Pkg/12 (Replace Annually)
PC551530	Nozzle O-Ring, (PC625), Pkg/10
PC551265	Nozzle Aiming Device (No Adaptor)
PC550926	KITCHEN KNIGHT II Aiming Device Adaptor (use with nozzle aiming device)
439876AS	New Aiming Device Adaptor



PC623



PC550016

DETECTORS AND PARTS

PART#	DESCRIPTION
PCFLH	Fusible Link Hanger
PC550131	FLK-1 Link Bracket Kit, 10"
PC550132	FLK-1A Link Bracket Kit, 8"



PCFLH

This 10" **FUSIBLE LINK BRACKET** is UL classified for use in Pyro-Chem® and Range Guard® systems, per NFPA 17 and 17A.

PART#	DESCRIPTION
LBK1	10" Fusible Link Bracket, ULC Classified



LBK1



Offering better air flow around fusible links, this 10" **HIGH STAND OFF FUSIBLE LINK BRACKET** is UL classified for use in Pyro-Chem® and Range Guard® systems, per NFPA 17 and 17A. And it will match up to a CP5 when coming through the top of a hood with a QSA12.

PART#	DESCRIPTION
LBK3	10" High Stand-off Fusible Link Bracket, ULC Classified, 1 1/8" to Centre of Hole

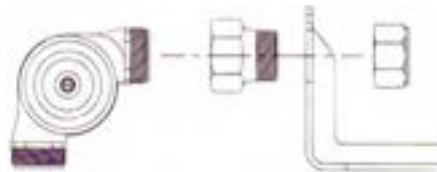


LBK3



Facilitating the attachment of an Ansul® or Pyro-Chem® large-threaded corner pulley to an LBK3 fusible link bracket, this **Link HOUSING ADAPTER KIT** reduces the larger threads of the corner pulley to fit the smaller-diameter link bracket hole. No conduit or conduit fittings are required either. Kit comes with one reducing adapter and one steel nut.

PART#	DESCRIPTION
LHAK	Link Housing Adapter Kit



CORNER PULLEYS

PART#	DESCRIPTION
423250AS	Ansul Corner Pulley, Compression Type
415670AS	Ansul Set Screw Corner Pulley
CP5	ULC Classified Compression Corner Pulley, 1/2" EMT
CP3	3-Way Corner Pulley



CP5



CP3

REMOTE PULL STATIONS AND ACCESSORIES

PART#	DESCRIPTION
PC551074	Remote Pull (RPSM)
ASBR	Ansul Style Remote Break Rods, 10/Pkg



ASBR

We are in the business of growing your business

FLEXIBLE CONDUIT AND ACCESSORIES

PART#	DESCRIPTION
434525AS	Flexible Conduit, 500'
435959AS	Flexible Conduit w/ Wire Rope, 500'
435979AS	Flexible Conduit Strain Relief, Pkg/50
434347AS	Flexible Conduit Inserts, Pkg/50
436150AS	P-Clips, Pkg/50
436063AS	Conduit Offsets, Pkg/6

PYRO-CHEM SYSTEM ACCESSORIES

PART#	DESCRIPTION
PC550698	Pyro-Chem® Wet Valve Rebuild Kit
PC551061	Pyro-Chem® Regulator Rebuild Kit
GPC225	Wet Chemical Gauge, 225 pis
PC550716	Pyro-Chem® O-Ring – For Wet Valve Neck (420716)
OR6	O-Ring, Upper Valve Stem (420716)



GPC225

SERVICE TOOLS

PART#	DESCRIPTION
PC550788	Wet Valve Tool
PC551240	Recharge Adaptor for Kitchen Knight II
HTA41	Hydro Adaptor, UL300 Pyro-Chem System
EZFILL	Liquid EZ-Fill Siphon Tube



HTA41



EZFILL

SERVICE MANUALS

PART#	DESCRIPTION
PC551274	Kitchen Knight Technical Manual, Electronic Copy

BRASS FLARE FITTINGS

BRASS FLARE FITTINGS are for system installations and meet SAE J513, as specified in the manufacturer's manual.

NOTE: Tees and connectors do not include flare nuts.

PART#	DESCRIPTION
FC25	¼", 45° Flare x ¼" NPT Male Connector
FN25	¼", 45° Flare Nut
FT25	¼", 45° Flare Tee



FC25



FN25



FT25

COPPER TUBING

Copper Tubing for Pyro-Chem system installations.

PART#	DESCRIPTION
CT50	¼" x 50ft Copper Tubing (½" Wall)



CT50

- **SHOP EQUIPMENT**





DRY CHEMICAL FILLING SYSTEMS



3G58836



3G59613



3G58616



3G59614



3G0050

ITEM#	3G58836	3G59613	3G58616	3G59614	3G0050
DESCRIPTION	50 lb. VacuFill Hopper System, SV1 50	50 lb. VacuFill Optimum Performance System	100 lb. VacuFill Hopper System, SV1 100	100 lb. VacuFill Optimum Performance System	100 lb. Dry Chemical Filling System
SPECS	<ul style="list-style-type: none"> • 1-50 lb Capacity hopper • 1-Single valve control console • 1-Filling line • 1-Discharge assembly • 1-Discharge screen • 1-Powder recovery lid • Operates on 60-80 PSI, 1-2 CFM 	<ul style="list-style-type: none"> • 50 LB Capacity hopper • Single valve control console • Filling line • Discharge assembly • Discharge screen • Slip on hopper filter • Clog resistant venturi • Smooth bore hopper outlet • Less maintenance and down time • Extinguishers fill up to 2X faster • Operates on 50-80 PSI, 2CFM 	<ul style="list-style-type: none"> • 1-100 lb Capacity hopper • 1-Single valve control console • 1-Filling line • 1-Discharge assembly • 1-Discharge screen • 1-Powder recovery lid • Operates on 60-80 PSI, 1-2 CFM 	<ul style="list-style-type: none"> • 100 lb Capacity hopper • Single valve control console • Filling line • Discharge assembly • Discharge screen • Powder recovery lid • Slip on hopper filter • Clog resistant venturi • Smooth bore hopper outlet • Less maintenance and down time • Extinguishers fill faster • Operates on 50-80 PSI, 2CFM 	<ul style="list-style-type: none"> • 100 lb (45 kg) Capacity • High Density Polyethylene (plastic) Hopper & Stand • No Rust • Translucent - See Chemical Level • Easy On/Off Switch on Console • Pneumatic Toggle Switch on Console has over 24 million cycles tested by manufacturer • Air Injection to "fluff" Chemical • Easy On/Off Lid & Filter • Inside Lip to Hold 45-50 lb Chemical Pail (20-22 kg) • 31 inches High (78.74 cm) • Same Console and Red Stand as 150 lb Hopper
RELATED ITEMS	3G58901 Maintenance Kit 3G59635 Optimum Perf Retrofit Kit	3G59637 Maintenance Kit	3G58900 Maintenance Kit 3G59635 Optimum Perf Retrofit Kit	3G58900 Maintenance Kit	3G0089 Maintenance Kit



3G0031



3G0086



3G0032



3G0116



3G0066



3G0061

ITEM#	3G0031	3G0086	3G0032	3G0116	3G0066	3G0061
DESCRIPTION	150 lb. ABC Dry Chemical Filling System	150 lb. ABC Dry Chemical Filling System, Industrial	150 lb. BC Dry Chemical Filling System	450 lb. ABC Dry Chemical Filling System, Portables Only	450 lb. ABC Dry Chemical Filling System, Portables Only	450 lb. ABC Dry Chemical Filling System, Wheeled Units & Portables
SPECS	<ul style="list-style-type: none"> • 150 lb (68 kg) Capacity • High Density Polyethylene (plastic) Hopper & Stand • No Rust • Translucent - See Chemical Level • Yellow Colored Hoppers for ABC Dry Chemical • Easy On/Off Switch on Console • Pneumatic Toggle Switch on Console has over 24 million cycles tested by manufacturer • Air Injection to "fluff" Chemical • Easy On/Off Lid & Filter • Inside Lip to Hold 45-50 lb (20-22 kg) Chemical Pail • 36.5 inches High (92.71 cm) 	<p>Same features as the standard 150 lb ABC system 3G0031 plus:</p> <ul style="list-style-type: none"> • 150 lb (68 kg) Capacity • These fill systems have safety components that are not present on our regular portables fill systems, including a reinforced discharge hose and a pressure relief device. • From 20 lb (9 kg) cylinders on an off-road vehicle system to 100 lb (45 kg) cylinders on a paint booth suppression system, this is a great tool for safely servicing industrial accounts on-site at the customer's location. • Ship Weight 90 lbs • THIS IS NOT DESIGNED FOR WHEELED UNITS 	<ul style="list-style-type: none"> • 150 lb (68 kg) Capacity • High Density Polyethylene (plastic) Hopper & Stand • No Rust • Translucent - See Chemical Level • White Colored Hoppers for BC Dry Chemical • Easy On/Off Switch on Console • Pneumatic Toggle Switch on Console has over 24 million cycles tested by manufacturer • Air Injection to "fluff" Chemical • Easy On/Off Lid & Filter • Inside Lip to Hold 45-50 lb Chemical Pail (20-22 kg) • Ship Weight 90 lbs 	<ul style="list-style-type: none"> • 450 lb (204 kg) Capacity - Yellow Hopper • THIS OPTION IS FOR PORTABLES ONLY • COMES WITH PORTABLES DISCHARGE HOSE AND ONE CONSOLE • Discharge one extinguisher at a time • High Density Polyethylene (plastic) Hopper & Stand • No Rust • Translucent - See Chemical Level • Easy On/Off Switch on Console • Pneumatic Toggle Switch on Console has over 24 million cycles tested by manufacturer • Air Injection to "fluff" Chemical • Easy On/Off Lid & Filter • Casters sold separately (3G0064) • Ship Weight 180 lbs 	<ul style="list-style-type: none"> • 450 lb (204 kg) Capacity - Yellow for ABC Chemical • THIS OPTION IS FOR PORTABLES ONLY • Discharge 2 extinguishers at one time • Fill 2 extinguishers at one time • High Density Polyethylene (plastic) Hopper & Stand • No Rust Translucent - See Chemical Level • Yellow Colored Hoppers for ABC Dry Chemical • Easy On/Off Switch on Console • Pneumatic Toggle Switch on Console has over 24 million cycles tested by manufacturer • Air Injection to "fluff" Chemical • Easy On/Off Lid & Filter • Caster sold separately (3G0064) • For White Hopper (BC) use part number 3G0065 • Ship Weight 180 lbs 	<ul style="list-style-type: none"> • 450 lb (204 kg) Capacity - Yellow Hopper ABC • THIS OPTION IS FOR PORTABLES & WHEELED UNITS • COMES WITH WHEELED UNIT DISCHARGE HOSE AND TWO CONSOLES • High Density Polyethylene (plastic) Hopper & Stand • No Rust • Translucent - See Chemical Level • Easy On/Off Switch on Console • Pneumatic Toggle Switch on Console has over 24 million cycles tested by manufacturer • Air Injection to "fluff" Chemical • Easy On/Off Lid & Filter • Caster sold separately (3G0064) • For White Hopper (BC) use part number 3G0063 • Ship Weight 180 lbs
RELATED ITEMS	3G0089 Maintenance Kit	3G0089 Maintenance Kit	3G0089 Maintenance Kit	1G0250 Replacement Filter 3G0124 Maintenance Kit	3G0121 Maintenance Kit	3G0122 Maintenance Kit



4G0083



3G59338



3G59748



3G59635

ITEM#	4G0083	3G59338	3G59748	3G59635
DESCRIPTION	Auto-Fill Station	Total Wheeled Unit Fill System	Universal Wheeled Fire Extinguisher Service Kit	Optimum Retrofit Kit for SV1 Console
SPECS	<ul style="list-style-type: none"> Auto-Fill Station comes with scale platform, fill cone hold down device, scale indicator, and auto-fill console. Can be used with existing VacuFill systems Increase productivity and improve fill weight accuracy Comes standard to automatically fill 5, 10, and 20 lb extinguishers. Other sizes can be filled by turning the switch to Manual. (2 kg, 4 kg, and 9 kg extinguishers) 	<ul style="list-style-type: none"> Fast Empties A 50# Container Of Chemical In Less Than 30 Seconds Mobile Or Shop Use Operates Via Gravity Quick/Clean Fill Process BUCKET NOT INCLUDED 	<ul style="list-style-type: none"> Necessary Fittings Adapters and Components Fits Most Models and Sizes of Wheeled Units Checks Regulators for Proper Dead Set Checks Regulators for Minimum Flow Clears Siphon Tubes and Agent Hose Assemblies Properly Verifies Nitrogen Cylinder Pressure Performs Operational Checks on Hose Assemblies, Gas Tubes, Nozzle Valves, Safety Relief's and Nitrogen Cylinders Pneumatic Tire Inflation Agent Hose Assembly Operational Integrity Agent Hose Assembly Clearing Nozzle Valve Operational Integrity Nozzle Valve Leakage Gas Tube Assembly Integrity Agent Cylinder Safety Relief Integrity 	<ul style="list-style-type: none"> Converts Your Standard Single Control Console to an Optimum to fill Extinguishers fill up to 2X faster Kit Fits SV1 50 Console (9G58836) Kit Fits SV1 100 Console (9G58616) Kit Fits SV1 150 Console (9G58619) Includes All the Parts Required to Change the Inside of the Console
RELATED ITEMS				

RECHARGE EQUIPMENT



3WV/4HN In Use

ITEM#	3WV
DESCRIPTION	3-Way 1/4" Valve
SPECS	This 3-WAY VALVE provides an easy and safe method of venting pressure when charging dry chemical and other low-pressure fire extinguishers. After reaching the correct extinguisher pressure and installing the extinguisher's pull pin, a half turn of the 3-way valve handle instantly bleeds off the pressure between the 3WV and the extinguisher (with minimal loss of nitrogen) for safe removal of the quick disconnect (QDC). Use the 4HN nipple to attach the quick disconnect. Maximum pressure is 500 psi.

GETZ SYSTEM MAINTENANCE KITS



3G58901



3G59637



3G58900

NEW



3G59634

NEW



3G58891

ITEM#	3G58901	3G59637	3G58900	3G59634 NEW	3G58891 NEW
DESCRIPTION	Maintenance Kit 58836 50# SV1 Steel Fill System	Maintenance Kit 59613 50# Optimum SV1 Steel Fill System	Maintenance Kit 58616/58619, 100/150# SV1 Steel Fill System	Maintenance Kit 59614/59615, 100/150# Optimum SV1 Steel Fill System	Maintenance Kit 58605 V2 Console 150# Steel Dual Hopper Fill System
SPECS	(1)-Lid filter (2)-Jar filters (1)-Jar gasket (1)-Venturi Yearly maintenance sticker Maintenance instructions	(3) - Jar Filters (1) - Jar Gasket (1) - Nut & ferrule 1/4" plastic (1) - Nut & ferrule 3/8" plastic (1) - Yearly maintenance sticker (1) - Lid Filter for 50lb Metal Fill System (1) - Pipe Elbow Plastic 1/4 Male x 1/2 Barb	(1)-Lid filter (2)-Jar filters (1)-Jar gasket (1)-Venturi Yearly maintenance sticker Maintenance instructions	(3) - Jar Filters (1) - Jar Gasket (1) - Nut & ferrule 1/4" plastic (1) - Nut & ferrule 3/8" plastic (1) - Yearly maintenance sticker (1) - Lid Filter for 50lb Metal Fill System (1) - Pipe Elbow Plastic 1/4 Male x 1/2 Barb	(2) - Clamps (6) - Jar Filters (2) - 1/4" X 3/8" Tube Connectors (2) - 1/4" X 1/4" Tube Connectors (2) - Jar Gaskets (2) - Nut & Ferrule 1/4" Brass (1) - Nut & Ferrule 1/4" Plastic (1) - Nut & Ferrule 3/8" Plastic (2) - Maintenance Record Label (2) - Lid Filter for 100/150 Metal Fill System (2) - Venturi Complete

NEW



3G58892



3G0089



3G0121

NEW



3G0124



1G0250



1G0067

ITEM#	3G58892 NEW	3G0089	3G0121	3G0124 NEW	1G0250	1G0067
DESCRIPTION	Maintenance Kit 58610 V3 Console 150# Steel Triple Hopper System	Maintenance Kit 100/150# Plastic Fill System	Maintenance Kit 450# Plastic Fill System - Dual Port	Maintenance Kit 450# Plastic Fill System - 1 Port	Filter for 450 lb Fill System Hoppers	Jar Filter
SPECS	(3) - Clamps (9) - Jar Filters (3) - 1/4" X 3/8" Tube Connectors (3) - 1/4" X 1/4" Tube Connectors (3) - Jar Gaskets (2) - Nut & Ferrule 1/4" Brass (1) - Nut & Ferrule 1/4" Plastic (1) - Nut & Ferrule 3/8" Plastic (3) - Maintenance Record Label (3) - Lid Filter for 100/150 Metal Fill System (3) - Venturi Complete	(1) - Hopper Lid Filter (1) - Jar Filter (1) - Jar Gasket (1) - Venturi Instructions Included	This is for a 450# fill system with 2 portable consoles. Includes: (1) - Hopper Lid Filter (4) - Jar Filter (2) - Jar Gasket (2) - Portables Venturi Instructions Included	This is for a 450# fill system with one portables console. Includes: (1) - Hopper Lid Filter (1) - Jar Filter (1) - Jar Gasket (1) - Portables Venturi Instructions Included		



ITEM#	1G54040	1G54039	1G54188	1G51436	1G0025
DESCRIPTION	Powder Recovery Filter, 15 x 15	Powder Recovery Filter, 13 x 13	Replacement Filter for 59602	Plastic Overflow Jar	Male Coupling 1/8" Male X 1/4" QC
SPECS	<ul style="list-style-type: none"> Slips over top of hopper Fits 100/150 lb hoppers New improved design Improves chemical dusting CO2, nitrogen or compressed air Comes with fill and discharge line 	<ul style="list-style-type: none"> Slips over top of hopper Fits 50 lb hoppers New improved design Improves chemical dusting 	<ul style="list-style-type: none"> Replacement lid filter Recommended change yearly 	<ul style="list-style-type: none"> Catches dry chemical filling overflow For all VacuFill systems Old #56325 	<ul style="list-style-type: none"> Slips over top of hopper Fits 50 lb hoppers New improved design Improves chemical dusting



ITEM#	1G0046	1G0048	1G0047	1G0049	1G0032	1G0033
DESCRIPTION	Tubing Poly 1/4" Red	Tubing Poly 1/4" White Vacuum Line	Tubing Poly 1/4" Yellow Vacuum Line	Tubing Poly 3/8" White Supply Line	Tubing 1/2" ID Clear Vinyl	Nylon Discharge Hose
SPECS	<ul style="list-style-type: none"> Tubing Poly 1/4 red line priced per foot. Old # 51551 	<ul style="list-style-type: none"> Tubing Poly 1/4 White vacuum line priced per foot Old # 51552 	<ul style="list-style-type: none"> Tubing Poly 1/4 Yellow vacuum line priced per foot. Old # 51553 	<ul style="list-style-type: none"> Tubing Poly 3/8 White priced per foot Old# 51554 	<ul style="list-style-type: none"> Tubing 1/2" ID Clear Vinyl sold per foot Used for the fill line to rubber cone and vent line from console Old # 51570 	<ul style="list-style-type: none"> Nylon Discharge Hose, priced per foot



ITEM#	1G0091	1G0084	1G0041	1G0028	1G0205	1G51428
DESCRIPTION	Dry Chemical Filling Cone	Ball Valve 1/2" F x F	Oetiker Hose Clamp, Ear 3/4"	Female Coupling Straight-Thru 1/4"	Jar Gasket	Meyer Hub
SPECS	<ul style="list-style-type: none"> VacuFill fill line rubber cone 		<ul style="list-style-type: none"> Oetiker Hose Clamp, Ear 3/4 Old# 51207 	<ul style="list-style-type: none"> 1/4" (0.635 cm) Female Quick Coupling 1/4" (0.635 cm) Female NPT Used on Dry Chem Filling System Discharge Line Old# 51254 	<ul style="list-style-type: none"> Jar Gasket Old# 51346 	<ul style="list-style-type: none"> Connects the discharge line and discharge screen to the hopper For the 50, 100, 150 lb and V1-2-3 VacuFill systems



3G59158



3G0151



1G0018



1G0030

ITEM#	3G59158	3G0151	1G0018	1G0030
DESCRIPTION	3 ft Discharge Hose 5/8" with Clamp	Venturi Tee 1/4 In Tube Brass	Vacuum Gauge	Male Coupling 1/4" X 1/4"
SPECS	<ul style="list-style-type: none"> • 3' Nylon hose with hose clamps • For discharge assemblies • Replace discharge hose when brittle or no longer transparent 	<ul style="list-style-type: none"> • Old# 58633 	<ul style="list-style-type: none"> • Gauge for all Dry Chem Filling Systems • 0 - 30 Hg Vacuum • Old# 51348 	<ul style="list-style-type: none"> • 1/4" (0.635 cm) Male Quick Coupling • 1/4" (0.635 cm) Male NPT • Fits Recharge Adapters • Old# 51258



3G58553



3G58651



3G58645



3G58644

ITEM#	3G58553	3G58651	3G58645	3G58644
DESCRIPTION	Fill Line Assembly With Cone	ABC On-Off Valve	BC On-Off Valve	Valve On/Off-Middle
SPECS	<ul style="list-style-type: none"> • VacuFill fill line assembly • For all dry chemical filling system • 8 ft of clear vinyl tubing 	<ul style="list-style-type: none"> • VacuFill control valve • For V1-2-3 VacuFill consoles 	<ul style="list-style-type: none"> • VacuFill control valve • For V2 & V3 VacuFill consoles 	<ul style="list-style-type: none"> • VacuFill control valve • For V3 VacuFill only



3G58649



B754W



1G0206

ITEM#	3G58649	B754W	1G0206
DESCRIPTION	SV1 On-Off Valve	Moisture Filter and Pressure Regulator	Filter Cap
SPECS	<ul style="list-style-type: none"> • VacuFill control valve • For SV1 consoles 	<ul style="list-style-type: none"> • If using compressed air to run the dry chemical fill systems it is necessary to take the moisture out of the lines. Moisture causes dry chemical to "cake" over time and will inhibit the system from working properly. • 1/4", 3/8" and 1/2" capabilities • Flow rate up to 100 SCFM 	<ul style="list-style-type: none"> • Filter Cap, Old# 51177

SHOP AND MOBILE PACKAGES



3G0128



3G0080

ITEM#	3G0128	3G0080
DESCRIPTION	Workbench, Shop Package	Workbench with Wall, Shop
SPECS	<ul style="list-style-type: none"> Includes Workbench as shown, 150 lb (68 kg) Dry Chemical Fill System, 110 lb (50 kg) Digital Scale, Airline Hose & Gun, Pneumatic Cylinder Vise, Plastic Tool Holder Door on left opens to two pull out drawers for o-ring and valve stem kits Workbench can be sold separately and customized to fit your needs <p>Workbench shown has following dimensions:</p> <ul style="list-style-type: none"> Workbench 63" Wide x 35" High x 23" Deep (160 cm wide x 88.9 cm high x 58.4 cm deep) Wall above bench 66" Wide x 29" High (167.6 cm wide x 73.7 cm high) 5 larger drawers and 2 smaller drawers inside door ASSEMBLY REQUIRED 	<ul style="list-style-type: none"> Door on left opens to two pull out drawers for o-ring and valve stem kits <p>Workbench shown has following dimensions:</p> <ul style="list-style-type: none"> Workbench 63" Wide x 35" High x 23" Deep (160 cm wide x 88.9 cm high x 58.4 cm deep) 5 larger drawers and 2 smaller drawers inside door



3G0126



3G0127

ITEM#	3G0126	3G0127
DESCRIPTION	Workbench 1 Drawer Pkg Full Size Cargo Van	Workbench 1 Drawer Pkg Compact Cargo Van
SPECS	<ul style="list-style-type: none"> Includes Workbench and Equipment as shown: Handwheel Vise, regulators, recharge line, standard 110 lb (50 kg) digital scale, air line with gun, 100 lb (45 kg) Dry Chemical Fill System, magnetic tool holder Workbench can be sold separately and customized to fit your needs Equipment options can be customized Ideal for rear facing in full sized cargo van or pickup truck installation Overall Dimensions: 52" Wide x 20" Deep x 38" High (132.08 cm x 50.8 cm x 96.52 cm) 	<ul style="list-style-type: none"> Includes Workbench and Equipment as shown: Handwheel Vise, regulators, recharge line, standard 110 lb (50 kg) digital scale, air line with gun, 100 lb (45 kg) Dry Chemical Fill System Workbench can be sold separately and customized to fit your needs Equipment options can be customized Ideal for rear facing in Transit Connect or similar sized vehicle Overall Dimensions: 47.25" Wide x 20" Deep x 38" High (120.012 cm x 50.8 cm x 96.52 cm) The one drawer is 11" Wide (27.9 cm)



2G0384



3G0125

ITEM#	2G0384	3G0125
DESCRIPTION	Workstation With Slide Out, No Equipment	Workstation With Slide Out and Equipment
SPECS		<ul style="list-style-type: none"> • Ideal for full sized cargo van or pickup truck installation • All Equipment shown is included • Workbench with 100% Full Extension Slide - 1,000 lb (453 kg) Capacity • Attractive Anodized Aluminum Construction • Up to 1000 lb (453 kg) weight rating • 100% Extension • Easy access release handle • Lighter than comparable steel slides • Corrosion resistant • Overall Dimensions: 60.25" Wide x 22.75" Deep x 46.25" High (153.04 cm x 57.79 cm x 117.48 cm)



2G0257

ITEM#	2G0257
DESCRIPTION	Van Slider 1000 lbs Full Extension
SPECS	<p>Aluminum cargo slides feature unsurpassed user function as well as an aesthetic design that compliments any vehicle. Manufactured of anodized aluminum extrusion and stainless steel components, these industrial slides offer a corrosion resistant alternative. Rolling resistance is kept to a minimum by using a revolutionary urethane roller system that allows effortless movement and a weight rating of up to 1000 lbs. (453 kg) at full extension. A limited lifetime warranty is included with all slides.</p> <ul style="list-style-type: none"> • Attractive Anodized Aluminum Construction • Up to 1000 # weight rating (453 kg) at 100% Extension • Easy access release handle • Lighter than comparable steel slides • Corrosion resistant • Overall Dimensions: 60" Wide x 21" Deep x 4.5" High (152.4 cm wide by 53.35 cm deep by 11.43 cm high)

DUST COLLECTION SYSTEMS



4G59542



1G53898



1G53899

ITEM#	4G59542	1G53898	1G53899
DESCRIPTION	120V Dust Collection System	Dust Collector Primary Filter	Dust Collector Secondary HEPA Filter
SPECS	<ul style="list-style-type: none"> Dust collection system 60 hz Single phase 120V 7.3 Amp motor 1220 CFM Air flow Side Air exhaust 24" x 24" x 4" Dust filter (standard) 24" x 24" x 4" HEPA filter Included White powder coat paint Rubber mat work grate Hinged side panels 51"H x 36"W x 25"D Ship Weight 260 lbs 	<ul style="list-style-type: none"> 24" X 24" X 4" Pleated filter Optional HEPA filter (8G53899) adds additional filtration 	<ul style="list-style-type: none"> Used in conjunction with filter 8G53898 Highest efficiency air filter Used to trap small particles

HYDROTEST EQUIPMENT

HYDROSTATIC TEST SYSTEMS



HTPVS



HTP1000



HTC



CAHTG



HTG



NH10

ITEM#	HTPVS	HTP1000	HTC	CAHTG	HTG	NH10
DESCRIPTION	Replacement Check Stem Kit	Hand Hydrostatic Test Pump	Test Cage	Calibratable Gauge for HTP1000	1000 PSI Gauge for HTP1000	10 ft High Pressure Hose
SPECS	<ul style="list-style-type: none"> Replacement check stem kit for HTP1000. This kit includes a pair of poppet valves. 	<ul style="list-style-type: none"> Designed for use in testing pressure vessels Efficient check stem Stainless steel piston Cast aluminum body 0 - 1000 PSI gauge Shipping weight 14 lbs. 	<ul style="list-style-type: none"> Test Cage manufactured to NFPA 10 specifications. Durable red powder paint finish, 13 gauge steel mesh with 11 gauge steel frame & mounting holes on the bottom. The top of the cage has a 1½" hole for the test hose and the door is on hinges with a latch for easy access. Shipping weight is 29 lbs. Measures 12½" x 12½" x 31½" 	<ul style="list-style-type: none"> Calibrated gauge for use with Hydrostatic Test Pump (HTP1000) 	<ul style="list-style-type: none"> Replacement 1000 PSI gauge with Hydrostatic Test Pump (HTP1000) 	
RELATED ITEMS	HTP1000		HTP1000	HTP1000	HTP1000	HTP1000

HYDROSTATIC TEST SYSTEMS



3G0078



3G58981



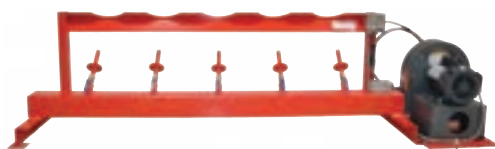
3G59558



1G51738

ITEM#	3G0078	3G58981	3G59558	1G51738
DESCRIPTION	Test Cylinder with Master Gauge	Hand Pump Hydro Test System	Hydro Test Conversion Kit to Add Water Reclaim Tank	MS36 Haskel Air Pump
SPECS	<ul style="list-style-type: none"> • Calibration Cylinder for Low Pressure Hydro-testers • Comes with DOT and NFPA compliant Gauge 	<p>DOES NOT Comply with U.S. DOT Regulations, Unless Used in Conjunction with Test Cylinder with Master Gauge 3G0078</p> <ul style="list-style-type: none"> • Hand Pump with 0-800 PSI Digital Gauge • Rotating Safety Cage • Air Blowout Valve for Quick Disbursement of Water from Extinguishers • Fill and Empty Lines Include Female • Quick Coupling • Garden Hose Hook Up 		<ul style="list-style-type: none"> • Air Pump for air operated hydr test systems 3G58630, 58880

CYLINDER DRYERS



CDHDCD



HE1500W



3G0008



3G0101

ITEM#	CDHDCD	HE1500W	3G0008	3G0101
DESCRIPTION	Heavy Duty Cylinder Dryer	Heating Element for CDHDCD	Cylinder Dryer Rack	Compact Cylinder Dryer
SPECS	<ul style="list-style-type: none"> • Heavy duty shop cylinder dryer rack. Unit comes with Blower and is pre-wired to be hooked up to a 120V power source. The dryer is 120V 60 Hz. • Now with ball valves to isolate drying parts to increase efficiency of drying • Length: 86" Width: 28½" Height: 21¾" • Ship Weight Approx. 150 Lbs. 	<ul style="list-style-type: none"> • Heavy duty long life heating element for CDHDCD dryer. 	<ul style="list-style-type: none"> • Cylinder Dryer Rack • Lightweight for UPS shipping • Drying ports can be isolated using ball valves • First drying port can be disconnected by ½" (1.27 cm) quick connect • Wheeled Unit Hose with adapter can then be dried on first port • Blower 3G0094 Sold Separately 	<ul style="list-style-type: none"> • This unit has our economy hot blower (3G0094) mounted inside. It can be used in a portables service truck or small shop • Temperature Controlled with Safety • 120 Volts A/C • 1 HP • 95 CFM

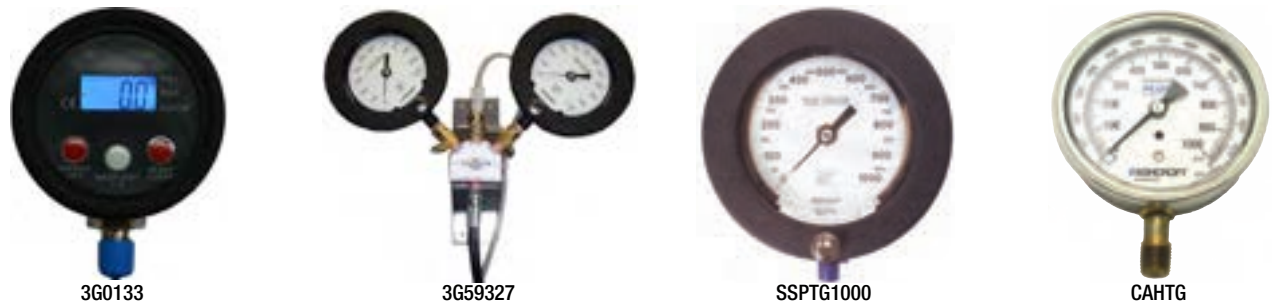
We are in the business of growing your business

CYLINDER DRYERS



ITEM#	3G59453	3G0047	3G0112 NEW	3G0094
DESCRIPTION	Heating Element for 9G59339	Hydro Aid Complete	Cylinder Dryer Hot Box	Economy Hot Blower
SPECS	<ul style="list-style-type: none"> Replacement heating element for 9G59339 Adapter kit included 1 Required 	<ul style="list-style-type: none"> Removes remaining dry chemical before hydro-testing Removes residual water after hydro-testing to decrease drying time Incoming air supply to 1/2" (1.27 cm) Ball Valve (100 psi max) 1.5" (3.81 cm) Vacuum Port for Shop Vac with HEPA filter Does not include Shop Vac 	<ul style="list-style-type: none"> Easy loading Quiet blower Heats cylinders inside and out Regulated heat up to 150 degrees Dries up to 11 cylinders at one time (4) Swivel casters Dimensions 54"W x 38"H x 30"D Space allowance should be 60"W x 60"H x 36"D 60 cycle 120 volts Requires a 20 AMP dedicated circuit Ship Weight 775 lbs 	<ul style="list-style-type: none"> Hot Blower for Dryer Rack 3G0008 Fits 2" Diameter Pipe Temperature Controlled with Safety Easily Connects to any dryer rack with supplied fitting 120 Volts A/C 1 HP 95 CFM

CALIBRATED AND TEST GAUGES



ITEM#	3G0133	3G59327	SSPTG1000	CAHTG
DESCRIPTION	Digital Gauge, Low Pressure Hydro-Tester	Dual Gauge Pressure Test Assembly	1000 PSI Certified Test Gauge	Calibrated Gauge for HTP1000
SPECS	<ul style="list-style-type: none"> Digital Gauge 0-800 Digital with Certification for low pressure hydro tester. 0.25% Accuracy Gauge is approved to test cylinders between 200-727 PSI Meets all NFPA and DOT requirements 20 Minute shut off 9 Volt Battery operated To calibrate gauge please notify us when ordering (CALIBRATION -#1G0239) 	<ul style="list-style-type: none"> (2) 4 1/2" 0-1100 PSI mirrored dial gauges 11 Point calibration certificate included Gauge accuracy of 1/4% full scale value (working) Gauge accuracy of 1/4% full scale value (master) Dual 45 degree gauge block design for easy readability Air bleed valve and drain line in top of gauge block 	<p>The certified test gauge for hydrostatic testing of low-pressure cylinders (required by NFPA 10). An additional gauge should be used as a master gauge for a daily system check as required by NFPA 10. Gauge is calibrated and certified prior to shipment.</p> <ul style="list-style-type: none"> 0-1,000 psi stainless steel gauge 3 1/2" Dial polycarbonate window 1/4" NPT bottom connection fits HTP Test Pump Rated -40°F to +200°F dry 	<ul style="list-style-type: none"> Calibrated gauge for use with Hydrostatic Test Pump (HTP1000)

HOSE TESTERS



4G58589



4G58918



3G58523



3G58584

ITEM#	4G58589	4G58918	3G58523	3G58584
DESCRIPTION	Electric Triple Hose Tester	Air Operated Triple Hose Tester	1 1/2" Cap IPT w/Bleed Valve	1 1/2" Plug IPT w/Quick Connect
SPECS	<ul style="list-style-type: none"> • Ideal for testing fire hose and wheeled fire extinguishers • 0-1000 PSI plunger pump • 0-600 PSI liquid filled calibrated gauge • 120 Volt 60 HZ Washdown duty electric motor • Adjustable internal bypass system • Aluminum manifold assembly • Fully enclosed support frame • (4) 4" Heavy duty casters • Tests 1, 2 or 3 fire hose at one time • Designed to meet NFPA service of fire hose 	<ul style="list-style-type: none"> • Ideal For Testing Fire Hose And Wheeled Fire Extinguishers • Completely Portable • Air Operated Motor • Operates With Shop Air Compressor Or Nitrogen Cylinder w/Regulator • 60 PSI At 2-4 CFM Per Minute • Internal Bypass System • Designed To Meet NFPA Service Of Fire Hose 	<ul style="list-style-type: none"> • Cap for use with hose testers, one cap and plug (9G58584) is needed per hose tested 	<ul style="list-style-type: none"> • Plug for use with hose testers, one cap (9G58523) and plug is needed per hose tested • Rated -40°F to +200°F dry

CYLINDER VICE



3G58634



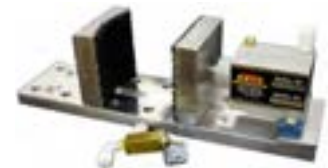
3G59419



3G58510



3G0038



3G0037

ITEM#	3G58634	3G59419	3G58510	3G0038	3G0037
DESCRIPTION	Pneumatic Cylinder Floor Vise	Pneumatic Belt Vise with Poker	Adapter Pad for Vise	Mechanical Bench Vise	Pneumatic Cylinder Bench Vise
SPECS	<ul style="list-style-type: none"> • Base plate mounted • Formed iron pedestal • Powder coated paint • Pneumatic-operated cylinder • Non-slip durable belting eliminates scratching of cylinders • Adjustable fits 5 lb To 100 lb CO2 cylinders • Vise opens and closes within seconds • Includes tool and stamp tray 	<ul style="list-style-type: none"> • Expanded capability • Accommodates large diameter cylinders • Propane cylinders • Clean agent cylinders • System cylinders • Ship weight 165 lbs 	<ul style="list-style-type: none"> • Adapter pad for use with • Oxygen and CO2 cylinders • Cylinders under 4" diameter 	<ul style="list-style-type: none"> • Compact-versatile-simple • Constructed of aluminum • Adjustable rear jaw • Jaws have non-slip belting • For shop or mobile use 	<ul style="list-style-type: none"> • Aluminum • Non-slip Belting • Operates on 60-80 psi • For Mobile or Shop Use • Pneumatic Toggle Switch has over 24 million cycles tested by manufacturer

CO2 TRANSFER PUMPS & CLEAN AGENT SYSTEMS



4G0010



4G59274



4G59578

ITEM#	4G0010	4G59274	4G59578
DESCRIPTION	CO2 Transfer Pump	HFC-227 Recovery/Recycle System	Tank Rec 50 lb Y-Valve Complete
SPECS	<ul style="list-style-type: none"> For use to pump CO2 from High Pressure CO2 supply cylinders or tanks Operated by Compressed Air or Nitrogen Comes with 4 CO2 Adapters 10 Feet (3.048 m) of 3/8" (0.9525 cm) White Poly Tubing 6 Feet (1.83 m) of 1/2" (1.27 cm) Supply Line Hose 6 Feet (1.83 m) of 1/4" (0.635 cm) Fill Line Hose Single Action Pump 130 PSI AT 13 CFM Ship Weight 40 lbs 	<ul style="list-style-type: none"> Designed with the operator in mind 99% transfer efficiency Transfers liquid, vapor and nitrogen HFC-227 Liquid transfer rate of 16 lbs per minute maximum HFC-227 vapor transfer rate of 2 lbs per minute maximum Filters particulate matter Indicates moisture Operates on compressed air pressure between 100-120 PSI at a minimum of 13CFM Space saving design Includes (4) adapters Compatible with FE 25, FE 125, Halon 1301, FM 200, Novec 1230 	<ul style="list-style-type: none"> Clean agent recovery tank 47.6LB water capacity DOT-RATED 4BW400 Comes with adaptors FE-36/HALOTRON 1 HALON 1211 NOVEC Other sizes available from 15-1000 lbs



4G59456



4G59543

ITEM#	4G59456	4G59543
DESCRIPTION	Wall-Mount High/Low CO2 Pump	Compressed Air Dryer
SPECS	<p>For use with low pressure supply bulk tanks only</p> <ul style="list-style-type: none"> Driven with low-pressure dry gas of 100 PSI (can be connected to gas use off liquid source) Special Order - 5 week lead time Fills CO2 extinguishers Fills CO2 cylinders 4 Fill adapters included Complete with pump and hoses Includes wall mounting bracket Variable filling rate from 1 to 15 lbs. per minute (controlled by gas flow rate of 13 CFM) Maximum outlet pressure: 1000 psi Wide liquid carbon dioxide inlet pressure range of 175 to 800 PSI to match typical storage systems Designed for long life and minimal maintenance Oil-less design eliminates product contamination <p>NOTE: An inline air dryer is required to prevent components from freezing. Either Getz# 4G59453 must be purchased with this unit or a waiver signed if you will source the dryer elsewhere</p>	<ul style="list-style-type: none"> Removes water from compressed air Uses activated alumina desiccant Dewpoint: -40F Removes particulate down to 1 micron Max oil content: .01mg per cubic meter at 70F Operates at 10 to 122F and 58-145 PSI Pre-filter and after-filter included Self-cycling with automatic included Self-cycling with automatic energy-saving mode Inlet: 3/8NPT female Outlet: 3/8NPT female 115 Vac/single phase/60hz Dimensions 19" x 12" x 39.5" Weight 81 pounds

• **INDEX**



STEEL
FIRE EQUIPMENT LTD.

A	Access Doors	44-45	B	Backpack Extinguishing System	63
	Utility Access Doors	44		Badger Extinguisher Part Pictograms	226-233
	Access Doors for Drywall Surface	44		Battery Units	129-132
	Fire Rated Access Doors, Standard	45		EBST Way2Go Series	129
	Adder Modules, Fire Alarm	89, 91, 93		EBST Series	130-131
	Aerosols and Lubricants	166		BECO Plastic Emergency Lights	132
	Brooks Sign On, Lube & Crazy Kleen	166		EBN Deluge	132
	WD40	166, 262		EBWP Weatherproof	132
	Lift Off® Adhesive Removal	166		Batteries	107-140
	Alarm Bells and Accessories	103		Beverage Cylinder Equipment	194
	Alarm Component Testing	122		Bulbs	141
	Db Checker	122		Brass Caps	62
	Air Velocity Tester	122		Brass Plugs	62
	Duct Checker	122		Brass Reducers	62
	Flame Checker	122		Brooks Mark Series Cabinets	37
	Alarm Pressure Switches	69, 105		Brushes	174
	Alkaline Batteries	106, 139		Buckeye Extinguisher Part Pictograms	234-237
	Amerex Extinguisher Part Pictograms	200-215			
	Amerex Fire Extinguishers	14-22			
	Annunciators and Back Boxes	93-95	C	Cabinet Alarms, Fronts, Locks & Labels	46
	Ansul Fire Extinguishers	23-30		Brooks Mark Series	46
	Ansul Extinguisher Part Pictograms	216-225		Warrior Series	46
	Ansul R-102 and Piranha Wet Chemical Systems	278-282		Chief Series	46
	Cartridges and Caps	278		Classic Series	47
	OEM Liquid Chemical	279		Customizer Panels	47
	Microswitches	279		Lock Fronts	47
	Nozzles	279		Elite Series	48
	Nozzle Blow-Off Caps, Adaptors and Aiming Devices	280		Locks	48, 49, 73, 74
	Nozzle Lubricant	280		Lock Boxes	49
	Detectors and Parts	280		Cabinet Alarms	49
	Corner Pulleys	280		Cabinets & Stands	37-43
	Gas Valves and Accessories	281		Cabinets, Plastic	37-40
	Remote Pull Stations and Accessories	281		Cabinets, Outdoor	38
	Flexible Conduit and Accessories	281		Cabinets, Fiberglass	39
	Ansul System Accessories	282		Stands, Extinguisher	40-41
	Ansul System Burst Discs	282		Cabinets, Metal	38, 41
	Service Tools	282		Cabinets, Architectural	42-43
	Service Manuals	282		Calibrated and Test Gauges	302
	Axes, Fire	63, 79		Caps	62-63
				Carbon Monoxide Alarms	110-111

10 Year Battery Operated	110	WAY2GO LED Combos	134
Battery Operated	110	CSRP Series	134
Hardwired AC Operated	111	CXST-CSST Series	135
Plug-In AC Operated	111	Brooks Plastic Combo	135
Wireless Interconnect	111	CRPN "Deluge" Wet Location Running Man Combo	135
Carbon Monoxide (CO) Detector Testing	121, 123-125	Conventional Detection/Input/Initiating Devices	96-98
Cartridge Bushings & Shipping Caps	188-189	Conventional Fire Alarm Panels	88-90
Filling Bonnets	188	Conventional Manual Pull Stations	96-97
Cartridge Bushings & Shipping Caps	188	MS-400	96
Cartridge Cap Wrench	189	MS-403/404 Emergency Manual Stations	96
Torque Wrench	176	MS 700 / MS 700U	96
CATO Chief Cabinets	40	Edwards 270 Series	97
CATO Warrior Cabinets	38	Conventional Smoke & Heat Detection	97-98
Cigarette Butt Receptacles	81	Edwards C2M Series	97
Circuit Breaker Lockout	73	System Sensor i3 Series	97
Classic Series Cabinets	41	System Sensor 100 Series	97
CO, Propane, Natural Gas Alarms	111	System Sensor 5600 Series Heat Detection	98
CO2 Horns, Nipples & Handles	191-192	Corner Pulleys	269, 280, 291
Wheeled CO2 Horn Assembly	191	Covers, Cabinets	46-48
CO2 Horns	192	Covers	32-36
CO2 Nipples, Rubber Handles & Clips	192	Hose Reel & Rack Covers	32, 35
CO2 Hose Assemblies	193-194	Wheeled Unit Covers	32, 36
CO2 Portable Extinguisher Hose	193	Extinguisher Covers	33, 34, 35
CO2 Wheeled Unit Hose	194	Hydrant Covers	34, 36
Dry Chemical Wheeled Unit Hose	194	Custom Engraved Signs	144-145
CO2 Recharge Adaptors	170	Custom Hydrotest and 6 Year Labels	158-159
CO2 Charging Line Components	170	Composite Cylinder Test Labels	158
CO2 Recharge Equipment	170	Hydrotest and 6 Year Maintenance Labels	158
Valve Handle Grip	170	Conductivity Test Labels	159
Masters Metallic Compound	170	Fire Hose Hydrotest Labels	159
CO2 Recharge Equipment	170	Cylinder Dryers	303
CO2 Safety Discs & Washers	191	Cylinder Rack System	74
CO2 Syphon Tubes	189	Cylinder Valve Cap	74
CO2 Transfer Pumps & Clean Agent Transfer Systems	306	Cylinder Valve Guard	74
CO2 Valves	189-190	Cylinder Vice	305
CO2 Extgr Valve for Steel Cylinder	189		
CO2 Extgr Valve for Alum Cylinder	189		
Wheeled Unit Valves	190	D Danger Signs	151
Codes and Regulations	75, 278	Detector Removal and Cleaning	121
Combination Units	134-135	Detector Sensitivity Testing	126

D	Disposal Cans	85	F	Fasteners	174-175
	Dry Chemical Filling Systems	294-296		EZ Anchor	174
	Dry Chemical, Steel Fire	2		EZ Toggle	174
	Dry Chemical, OEM	3		Self Tapping Concrete Anchors	174
	Dry Chemical Recharge Adapters, Air Valves	171		Self Drilling Steel Fasteners	175
	Recharge Adapters	171		Filling System Maintenance Parts and Kits	297-299
	Ductmate Rectangular Hi-Temp Access Doors	276		Fire Alarm Batteries	107
	Dust Collection System	302		Fire Alarm Control Panels, 2 to 6 Zone	88
				Fire Alarm Control Panels, 8 to 72 Point Panels	88-89
				Fire Alarm Control Panels, Intelligent	90-91
E	Elite (Semi) Recessed & Surface Mount Cabinets	42-43		Fire Alarm Control Panels, Releasing	92
	Electrical Contactors	261		Fire Alarm Electrical Cable	104
	Emergency Burn Care	76-77		Fire Alarm Inspection, Testing and Maintenance Products	120-126
	Emergency Light Batteries	107-140		Fire Alarm Service Labels	120
	EMT Conduit Fittings	267		Fire Alarm Signs	149
	End of Line Resistor Plates	90, 93		3D Rigid Plastic	149
	Escape Ladders	78		Vinyl Self Adhesive Signs	149
	Escutcheons	66		Fire Blankets and Cabinets	77-78
	Exit and Emergency Lights	127-142		Fireboy Automatic System	6-8
	Exit Signs	136-137		Fire Department and System Signs	69, 153
	RPST Series	136		Fire Extinguishers	9-30
	RPNP Series	136		Strike First	9-13
	RPN Deluge	136		Stored Pressure	9-10
	EXST-SXST Series	137		CO2	11
	EXPT Series	137		Water	12
	Brooks Plastic LED Exit Sign	137		K-Class	13
	Exit Signs and Directional Arrows	148-149		Extgr Cart	13
	3D Rigid Plastic	148		Amerex	14-22
	Aluminum	148		Stored Pressure	14-15
	Rigid Plastic	148		CO2	16
	Vinyl Self Adhesive Signs	149		Water & Foam	17-18
	Extinguisher Cabinet Decals	50, 148		K-Class	18
	Extinguisher Covers	33-36		Wheeled	16-17, 20-22
	Extinguisher Operating Labels	155-156		Class D	19
	Fire Classification Labels	155		Halotron	20
	Pictorial Operating Labels	156		Ansul	23-30
	Extinguishing Systems	4-8		Stored Pressure	23-24
	Torrent	4-5		Cartridge Operated	25
	Fireboy	6-8		CO2	26-27
	Eye Protection	79-80		Water	28

K-Class	28	Fryer Panels	276
Wheeled	27, 30	Funnels, Scoops and Air Hose	167
Cleanguard	29	Filling Funnels	167
Fire Extinguisher Parts	179-189, 200-255	Scoops	167
Fire Extinguisher Signs	50, 146-148	Pail Opener	167
3D Rigid Plastic	146	Blow Gun	167
Aluminum	146	Air Hose and Reels	167
Rigid Plastic	146-147	Fusible Links	264-266, 286
Rigid Plastic 90° Angle Signs	147		
Vinyl Self Adhesive Signs	147		
Sign-On Adhesive	148	G Gas Valves and Accessories	258-259, 281
FireTech Cabinets	38-39	Asco Gas Valves	258
Fire Hose	55-57	Ansul Gas Valves	258, 281
Rack and Reel Fire Hose	55	Gas Valve Accessories	259
Single Jacket Fire Hose	56	Gas Valve Lockout	72
Double Jacket Fire Hose	56	Gate Valve Lockout	72
Washdown Fire Hose	57	Gated Wye Valves	62
Forestry Fire Hose	57	Glow in the Dark	154
Rubber Covered Fire Hose	57	Glow in the Dark Self Adhesive Signs	154
Fire Hose Couplings, Rings & Gaskets	58	Photoluminescent Exit Signs	154
Fire Hose Couplings	58	Grease Comb	276
Fire Hose Gaskets	58	Grease-Tite Adapters and Patch Seals	268-269
Fire Hose Expansion Rings	58	Gauges	60, 180
Fire Hose Hydrotest Labels	54, 159	Clean Agent	180
Fire Hose Nozzles	54	Dry Chemical	180
Fire Hose Signs	51, 64, 150	Nitrogen Valve	180
Rigid Plastic	51, 64, 150	Pressurized Water, Foam, Loaded Stream	180
Vinyl Self Adhesive Signs	57, 64, 150	Sprinkler	66
Fire Rated Access Doors, Standard & Basic	41	Gauge Service Equipment	175, 181
Fire Retardant	78	Bubbles Leak Detector	175, 181
Fire Safety Plan Boxes	50	Gauge Tester	175
First Aid Signs	76, 150-151	Gauge Wrench	175
3D Rigid Plastic	76		
Rigid Plastic	76	H Handcare Products	178, 262
Vinyl Self Adhesive Signs	150-151	Headlights	178
Fire Sprinkler Monitoring	69, 70, 105, 106	Heat Detector Testing	122
Firestop and Hood Caulk	277	Hole Punches and Chain Reel	162, 164
Fittings Tote Tray	67	Hood Grease Filters and Accessories	274-275
Flag Fire Extinguisher Part Pictograms	238-243	Hood Filters	274
Form Holder	79		

H	Filter Spacers	275	Control Equipment	284-286
	Hood Light Fixtures	275	UCH Universal Control Head	284
	Horns and Strobes	102	Actuation Cartridges	285
	Genesis® G1	102	Pressure Switches	285
	MGC FH-400 Horns	102	Mechanical Actuation Devices	285
	MGC FS-400 Strobes	102	Mechanical Detection Links	286
	MGC FHS-400 Horn/Strobes	102	Dry Chemical Reserve System Hardware	286
	682 Mini Horn	102	System Maintenance and Recharge	287
	683 Mini Horn	102	Service Tools	288
	Horn/Strobe/Beacon Covers	118-119	Detect-A-Fire Heat Detectors	288-289
	Horn/Strobe/Speaker Damage Stopper	118	Brass Flare Fittings	289
	Strobe Damage Stopper	118	Inspecta-Shield Fire Retardant	78
	Stopper Dome	118	Inspection and Installation Forms	263
	Smoke Detector Damage Stopper	119	Inspection Tags	55, 160-161
	Steel Web Stopper for Smoke Detectors	119	Plastic Inspection Tags	160
	Smoke Alarm Guard	119	Monthly Inspection Tags	160-161
	Hose Hangers	59	4 Year Plastic Inspection Tags	160
	Hose and Horn Bands and Straps	192-193	4 Year Metal Inspection Tags	161
	Hose Racks	59	Monthly Inspection Label	161
	Hose Reels	60	Fire Hose Inspection and Test Label	55, 161
	Hose Reel & Rack Covers	32, 35, 60-61	Intelligent Detection/Input/Initiating Devices	99-101
	Hose Testers	305	Intelligent Input/Output	99-103
	Hose Trays	60	Intelligent Pull Stations	100-101
	Hose Valves	61	Intelligent Smoke/Heat/Duct Detection	99-100
	Angle Hose Valves	61		
	Gated Wye Valves	61		
	Hydrant Covers	34, 36	J Justrite Safety Products	81, 83-86
	Hydrotest Adaptors	172-173		
	Low Pressure Hydrotest adaptors	172		
	High Pressure Hydrotest adaptors	173	K Kidde Extinguisher Part Pictograms	244-247
	Cartridge Test Adaptors	173	Kidde System Wet Chemical Systems	283-289
	Hydrotest Equipment	302-303	Cylinder Installation	283
	Hydrotest Labels	54, 158, 159	Nozzles and Accessories	283-284
	Hydrant Spanner Wrenches	63	Control Equipment	284-286
			UCH Universal Control Head	284
			A+ Control Head	285
			Actuation Cartridges	285
			Pressure Switches	285
			Mechanical Actuation Devices	285
			Mechanical Detection Links	286
I	In Case of Fire Labels	147, 148, 149, 157		
	Industry Guard Dry Chemical Systems	283-289		
	Cylinder Installation	283		
	Nozzles and Accessories	283-284		

Dry Chemical Reserve System Hardware	286	Component O-Rings	184-185
System Maintenance and Recharge	287	Gaskets and Quad Rings	185
OEM Liquid Chemical	287	O-Ring Kit	185
Service Tools	288	O-Ring Lubricants	185
Service Manuals	288		
Detect-A-Fire Heat Detectors	288-289		
Older Range Guard Parts	289	P Paintball Recharge Kit	170
Brass Flare Fittings	289	Panel Enclosures	89-91
		Photoluminescent Exit Signs	128-129, 154
		Pipe Fittings and Nipples	270
L Labels	155-159	Stainless Steel Fittings and Pipe Nipples	270
Extinguisher Operating Labels	155-156	Black Pipe Fittings and Pipe Nipples	271-272
WHMIS Labels	157	Chromed Pipe Fittings and Pipe Nipples	272
In Case of Fire Labels	157	Chrome Sleeving	272
Transport of Dangerous Goods Labels	157-158	Pipe Stand-off Brackets	273
Custom Hydrotest and 6 Year Labels	158-159	Plastic Break Caps	63
LED Retrofit Bulbs	130, 133, 141	Plastic Caps	62
Link Brackets and Adapter Kit	267, 269, 280, 291	Plugs	62
Lithium Batteries	106, 140	Plunger Cans	81
Locks	48-49, 73-74	Protective Clothing	86, 277
Lock Boxes	49	Pull Pins, Chain and Key	188
Lock Fronts	47	Pull Station Guard	116-117
Lockout Tagout	72-73	Stopper II Indoor Use	116
Log Books	74-75	Stopper II Weather Stopper Indoor/Outdoor Use	116
		CATO Protective Covers	117
		Universal Stopper	117
M Manual Pull Station Guards	96-97	Pyrene Extinguisher Part Pictograms	248-249
Microswitches	260, 279, 290	Pyro-chem Kitchen Knight System Parts	290-292
Multi-Criteria Detector Testing	124-125	Actuation Cartridges	290
		OEM Liquid Chemical	290
		Microswitches	290
N NFPA Publications	75	Nozzles	290
Nipple Tote Box	67	Nozzle Blow-Off Caps, Adaptors and Aiming Devices	291
Nitrogen Regulator and Accessories	168	Detectors and Parts	291
Nitrogen Valves	190-191	Corner Pulleys	291
Brass Commercial Nitrogen Valves	191	Remote Pull Stations and Accessories	291
Wheeled Unit Valves	190	Flexible Conduit and Accessories	292
		Pyro-Chem System Accessories	292
		Service Tools	292
O OEC Series Cabinets	38	Service Manuals	292
O-Rings	184-185		

P	Brass Flare Fittings	292	RMMD	133	
	Copper Tubing	292	RMMB	133	
<hr/>					
Q	Quick Mount Fasteners and Tools	263, 274	RMN Deluge	133	
<hr/>					
R	Range Guard Wet Chemical Systems	283-289	Reset Relays	260	
	Cylinder Installation	283	Resettable Bi-Metal Fire Link	266	
	Nozzles and Accessories	283-284	Respiratory Protection	80-81, 169	
	Control Equipment	284-286	Restaurant System Parts	257-292	
	UCH Universal Control Head	284	Rivets	185-186	
	A+ Control Head	285	Rivet Kit	185	
	Actuation Cartridges	285	Rivets	186	
	Pressure Switches	285	<hr/>		
	Mechanical Actuation Devices	285	S	Safety Storage Cabinets	82-84
	Mechanical Detection Links	286		Safety Storage Cans	85-86
	Dry Chemical Reserve System Hardware	286		Scales	168
	System Maintenance and Recharge	287		Hanging Scales	168
	OEM Liquid Chemical	287		Cartridge Scales	168
	Service Tools	288		Spring Dial Scales	168
	Service Manuals	288		Utility Scales	168
	Detect-A-Fire Heat Detectors	288-289		Digital Scales	168-169
	Older Range Guard Parts	289		Legal-for-Trade Scales	169
	Brass Flare Fittings	289		SDS Document Storage	85
	Recharge Chemical	2-3, 279, 287, 290		Sealed Lead Acid Batteries	107, 140
	Recharge Equipment	169		Self-Luminous Tritium Exit Signs	128
	3-Way Filling Valve	169		Service Tags	159-160
	Rubber Mallet	169		Blank Service Tags	159
	Pouring Bags	169		Custom Service Tags	159-160
	Disposable Comfort Mask	169		Repair Tag	160
	Blow Out Bag	169		Condemned Tag	160
	EZ Fill Siphon	169		Sherwood Carbon Dioxide & Nitrogen	190-191, 249
	Reducers	62		Commercial Valves	
	Releasing Control Panel	92		Shop Recovery and Recharge Equipment	294-296
	Replacement Bulbs	141		Signaling/Output Devices	102-103
	Remote Heads	13		Signs	146
	RMSM Series	133		Fire Extinguisher Signs	146-148
	RMSM LED	133		Extinguisher Cabinet Decals	148
	LED Retrofit	133		Exit Signs and Directional Arrows	148-149
				Fire Alarm Signs	149
				Fire Hose Signs	150
				First Aid Signs	150-151
				Danger Signs	151

Sprinkler Identification Signs	152-153	Tag Fasteners	161
Fire Department and System Signs	153	Tamper Seals	67, 165, 186-187
Glow in the Dark	154	Temperature Labels	267
No Smoking	155	Test Balloons	277
Smoke Alarms	108-110	TestiFire Test Kits	124-125
10 Year Battery Operated	108	Test Equipment and Labels	138
Battery Operated	108	Lighting Service Labels	138
Hardwire AC Operated	109	Battery Tester	138
Wireless Interconnect	110	Multi-Meter	138
Smoke Alarm Guard	119	Glass-Strapping Tape	138
Smoke and Heat Detector Test Kits	123-125	Mini-Volt Stick	138
Smoke Cartridges	277	Battery Leads	138
Smoke/CO Combination Alarms	112-114	Thermal Link	266
10 Year Battery Operated	112	Thermo Bulb Links	266, 286
Battery Operated	112	Tools	175-177, 262
Hardwired AC Operated	113	Cylinder Inspection	175
Wireless Interconnect	114	Pliers	176
Smoke Detector Testing Aerosol	120-121	Wrenches	176
Smoke, CO Alarms & Accessories	108-115	Miscellaneous Tools	177
SOLO Access Poles	122	Cutter, Cable and Tube	262
Spanner Wrenches	63	Crimping Tools	262
Sprinkler Gauges	66	Drill Bits	262
Sprinkler Head Cabinet	67	WD40	166, 262
Sprinkler Heads	66	Torrent Automatic System	4-5
Sprinkler Identification Signs	68, 152	Traffic and Roadside Safety	79
Stainless Steel Cable, Crimps and S-Hooks	261	Transport of Dangerous Goods Labels	157-158
Stainless Steel Cleaner/Polisher	276	Non Flammable Gas Labels	157
Stamp Holder and Steel Stamps	173	Transport Canada Labels	158
Station Momentary Mushroom	93, 97	Department of Transportation (DOT)	158
Steel Fire CO2 Extinguisher Pictograms	255		
Strike First Fire Extinguishers	9-13	U Universal Stopper Products	117
Strike First Extinguisher Part Pictograms	251-254	Utility Access Doors	44
Supervisory Switches	69, 105		
		V Valve Stems	181-184
T Tags	159-161	Dry Chemical	181
Service Tags	159-160	Pressurized Water, Foam, Loaded Stream	182
Inspection Tags	160-161	CO2	183
Tag Covers and Fasteners	161	Clean Agent	183-184
Tag Covers	161		

V	Valve Tamper Seals	67
	Vehicle Brackets	195-196
	Heavy Duty Vehicle Brackets	195
	Cartridge Operated Vehicle Brackets	195
	Universal Brackets	195-196
	OEM Vehicle Brackets	196
	Verification of Service Collars	162
	Verification of Service Collars	162
	Plastic Verification of Service Collars	162
	Custom Verification of Service Collars	162
	Visual Signaling/Hearing Impaired	109, 113
	Kidde Hardwired Smoke Alarm with Strobe	109, 113
	BRK Hardwired Smoke Alarm with Strobe	109
	BRK Smart Strobe	109
<hr/>		
W	Wall Hangers	197, 198
	Waterflow Detectors	70, 106
	Waterjel Products	76-77
	Wet Chemical, OEM	3
	WHMIS Labels	157
	Wheeled Unit Covers	32, 36
	Williams Brothers Safety Cabinets	82
	Wireless Interconnect System	110, 111, 114, 115
	Kidde Wireless Interconnect System	110, 114
	First Alert Wireless Interconnect System	110, 111, 114, 115
	Wire Guards	139
	Exit Sign Damage Stopper	139
	Emergency Lighting Cage	139
	Wrenches	63, 67
	Sprinkler Wrenches	67
	Spanner Wrenches	63
	Hydrant Spanner Wrenches	63